

## ULTRA LOW-LEVEL BIREFRINGENCE MEASUREMENTS OF LCD MATERIALS

### Sub-Nanometer Level Metrology

Exicor birefringence technology has been adopted by the world's leading optics manufacturers to measure birefringence with unsurpassed accuracy and repeatability. With a retardation resolution of only 0.005 nm, Exicor is uniquely suitable for ultra-low retardation measurement applications and stress estimation.

### Exicor GEN6 LCD

Following years of experience working with the world's leading manufacturers of optical materials, Hinds Instruments introduced the Exicor 1500AT system for measurement of large surface area optical materials such as those used in LCDs (up to 1500mm x 1500mm). As LCD materials specification have matured specialized systems that are scaled to the industry needs have become necessary. The smaller Exicor GEN6 LCD is built on the core of the successful Exicor 1500AT design and is scaled to measure Generation 6 (and smaller) LCD display components.

The growing LCD industry demands the highest sensitivity available in order to reliably produce precision LCD display components. The Exicor GEN6 LCD is equipped with our popular Exicor MT system. Now built

in volume, the Exicor MT is used in all of our visible wavelength systems and custom OEM applications. It provides excellent measurement performance while offering the convenience of easy removal and replacement for maintenance.

### Repeatability, Assured

Hinds Instruments' worldwide customer base has confidence in Exicor technology and our measurements. We include a low level retardation sample with high homogeneity and extremely low retardation with every GEN6 LCD system. The automatic offset feature of all Exicor systems may be set to remove traces of noise and provide retardation measurement repeatability to 0.005 nm. A solid, dependable reference sample at this low level ensures your measurements are accurate... every time.



Aunion Tech Co.,Ltd

Room2802, F Building, No. 86 Caobao Road, Shanghai 200235, China

Tel: +86-21-51083793

Fax:+86-21-34241962

E-Mail: [info@auniontech.com](mailto:info@auniontech.com)

Website: [www.auniontech.com](http://www.auniontech.com)

**Important Features**

- ◆ Small footprint – Minimizes the factory floor space required for the equipment
- ◆ Innovative stage design – Patented design maximizes measureable area
- ◆ Robust Automation – Quality stages and hardware maximize uptime
- ◆ Solid Service Support – Support and spare parts centers throughout the world
- ◆ Industrially Compliant – Built to meet S2/S8 and CE standards
- ◆ Flexible Software – Optimized GUI software. Custom features and DLL interface available
- ◆ Low Maintenance Design - Easy access to components for service
- ◆ Load Assistance - Tilt Stage Option

**The Exicor NEXUS Program**

Exicor at the Center! This program is aimed at helping our customers identify and develop the best possible birefringence measurement solution for their unique set of circumstances.

This can be especially challenging in the case of production line applications and the integration of Exicor equipment.

The main driver for the development of this program is that most of our customers add Exicor to their application as an afterthought. Hinds Instruments staff has specialized in adapting our equipment to meet the customer's requirements, but are often developing around areas in the process or facility that are not optimal for birefringence measurement and that could have been avoided.

By the very nature of the birefringence measurement market, we are quite adept at dealing with these challenges. The fact our team does this, and even specializes in it, is often overlooked by our customers. Typically this is because they fear asking us to customize (fear of cost) or they don't know enough about birefringence measurement to know what questions to ask before it is too late!

The Exicor NEXUS Program formalizes what we already do and gets Hinds Engineers involved with you as early as possible. This allows us to recommend the best possible solution for maximizing performance and minimizing long term cost impacts. Contact us to learn more!

**TYPICAL PERFORMANCE SPECIFICATIONS**

Retardation Range	0.005nm to 120 nm
Resolution <sup>1</sup>	0.001 nm
Repeatability <sup>1</sup>	±0.01 nm (Retardation < 1 nm) or ± 1% (Retardation > 1 nm)
Angular Resolution/Repeatability <sup>1</sup>	0.01° / ± 0.05°
Measurement Time <sup>2</sup>	Up to 10 pps
Modulation Frequency	50 kHz
Wavelength <sup>3</sup>	632.8 nm
Spot size	~1 mm typical
Demodulation Analysis Technique	Hinds Instruments Signaloc™ Lock-in Amplifiers
Measurement Units	nm (retardation), ° (angle)
Maximum Sample Size	1600 mm x 2000 mm

<sup>1</sup> Typical performance at 5nm Retardation

<sup>2</sup> Maximum data collection speed. Sample XY scan time dependent on stage movement parameters.

**Aunion Tech Co.,Ltd**

**The World's Most Advanced Low-Level Birefringence Measurement Technology**

Founded in 1971, Hinds Instruments has grown to become the leader in implementing polarization modulation technology. Our mission continues to be the development and refinement of systems and components designed to meet the demanding need for high sensitivity polarization measurements.

Out of this mission, our scientists and engineering staff developed a low-level birefringence measurement technology to improve the performance of our own core products. This development became the Exicor Birefringence measurement system, a metrology platform that surpassed the capability of all previous and current technologies.

Since the introduction of the Exicor platform, over 90% of the major calcium fluoride and fused silica manufacturers have adopted this leading edge technology. The list of industries

using Exicor is expanding and now includes liquid crystal display manufacturers.

Exicor has become the preferred standard for the top international research organizations and optical materials manufacturers. The performance of the system has been authenticated in the peer-reviewed Review of Scientific Instruments, the leading journal for accrediting new leading-edge scientific and technical instrumentation.

Additionally, the Exicor birefringence measurement system has won numerous awards. The 2000 Photonics Circle of Excellence Award honored the most technically innovative photonics products of the year in worldwide competition. Exicor also received the 2001 R&D 100 award in worldwide competition, recognition that compared Exicor technology to the published claims of competing technology. This very prestigious distinction was awarded to the best 100 new technologies in all fields of science throughout the world.

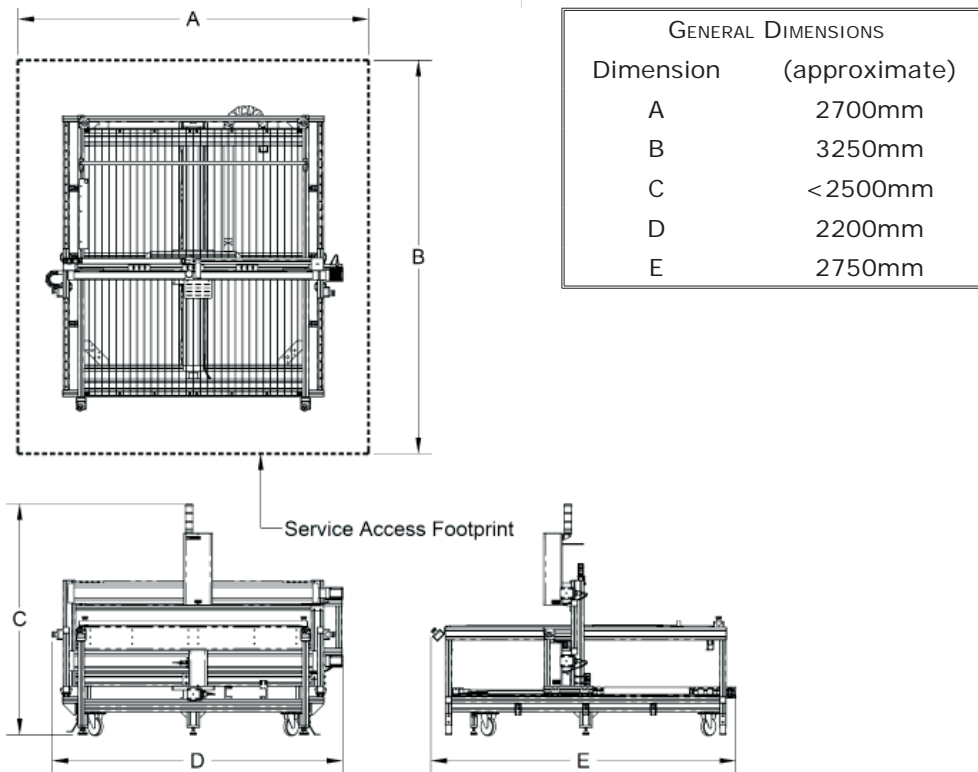

Aunion Tech Co.,Ltd

Room2802, F Building, No. 86 Caobao Road, Shanghai 200235, China

Tel: +86-21-51083793

Fax:+86-21-34241962

E-Mail: [info@auniontech.com](mailto:info@auniontech.com)

Website: [www.auniontech.com](http://www.auniontech.com)