

specification | general



rhea  
spectrometer





## Contents

1	Rhea series: high end spectrometer .....	3	8	System performance .....	11
2	Highlights.....	3	8.1	Dark current.....	11
3	Speed & ease of use.....	4	8.2	Non-linearity .....	11
4	Custom or OEM.....	4	8.3	Wavelength calibration .....	11
5	Rhea general specifications .....	4	8.4	Stray light .....	11
6	Rhea at a glance .....	5	8.5	Absolute calibration .....	11
6.1	System response .....	5	8.6	Spectrometer output.....	11
6.2	Detector .....	5	8.7	Production .....	11
6.3	Slit size .....	5	9	Order codes.....	12
6.4	Gratings.....	5	9.1	Rhea system order code .....	12
6.5	Dispersion range .....	6	9.2	Rhea configuration order code.....	12
6.6	Filter wheel.....	6	9.3	Rhea order code example.....	12
6.7	Start and stop wavelength.....	6	10	Pre-configured spectrometers.....	13
7	System configuration.....	7	10.1	Colour measurement.....	13
7.1	200 grooves system response .....	8	10.2	Broadband measurement.....	13
7.2	300 grooves system response .....	8	10.3	Raman 785nm.....	13
7.3	500 grooves system response .....	8	10.4	Raman 532nm.....	13
7.4	600 grooves system response .....	9	10.5	Laser analysis .....	13
7.5	900 grooves system response .....	9	11	Rhea dimensions.....	14
7.6	1200 grooves system response .....	9			
7.7	1600 grooves system response .....	10			
7.8	1800 grooves system response .....	10			



## 1 Rhea series: high end spectrometer

The Rhea series spectrometer offers a unique combination of ease of use and accurate measurement capabilities packed in a robust package. The Rhea utilizes a high-end cooled CCD detector for low noise and high dynamic range. The Neutral Density filter wheel extends this dynamic range and also adds a shutter function. An ideal device for measurements where ease of use, stability, performance and price are of the essence. All in all the perfect solution for hassle free integration in your product or process. The Rhea spectrometer can virtually cover any wavelength range in the 200-1100nm range. Standard versions (like UV, VIS and NIR) are available. Additionally, we also support a broad range of gratings for specific applications.

The Rhea series is available in a variety of optical fiber connected 5, 10 or 20mm collimating lenses or a 1cm<sup>2</sup> cosine corrector. For measurements of light sources Admesy offers a range of integrating spheres and other accessories. The M8 fixed position fiber connector has been developed to ensure that the optical fiber has a fixed and uniform optical connection for both calibration and customer application. Also, due to this fixed position measurement results are more stable. Additionally, Admesy also offers SMA connection.

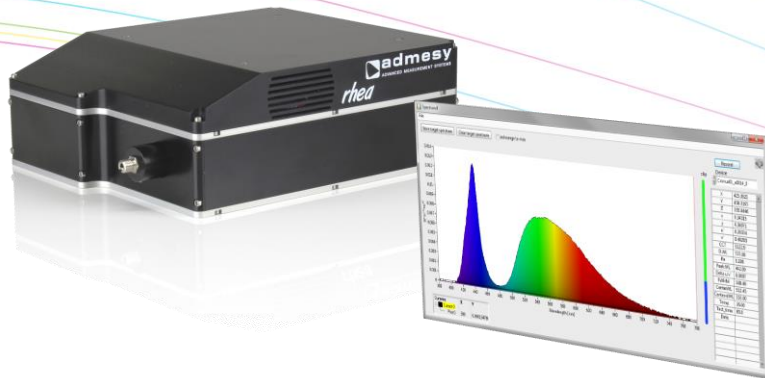

## 2 Highlights

- Various spectral ranges including UV, VIS and NIR within the 200-1100nm range
- Cooled high-end CCD detector, cooled to -10 degrees Celsius
- High optical throughput design
- Neutral density filter wheel for huge dynamic range
- Shutter function
- Low noise
- Auto-range function
- Wavelength calibrated
- Very low stray light
- Excellent linearity, internally compensated within 1%
- Dark current compensated, virtually zero over entire integration range
- USBTMC compliant, SCPI command set, high speed device
- USB, RS232, Ethernet connections and trigger in & out for ideal system integration
- Internal calculations for most common parameters, saving processing power in production environments
- Robust housing, optimized for mounting and protection in harsh production environments
- M8 or SMA fiber connection





### 3 Speed & ease of use

Admesy strongly believes in developing and manufacturing devices where ease of use and speed are key factors. In order to achieve these aspects, Admesy considers the following aspects of spectrometers to be taken care of:

- Wavelength calibration
- Dark current
- Linearity
- Absolute calibration
- OD filter calibration

Calculations, compensations and data transfer are done in a staggering 15ms. All this is possible due to the high speed processor inside the Rhea combined with algorithms developed for this specific device. In production processes, no external calculation power is needed from computers. Data can be used directly in production settings without any delay of processing data afterwards. This saves time and processing power of the operating system of a production line.

When for example the integration time is set to 10ms, the full calibrated spectral data is processed and transferred through high speed USB.

### 4 Custom or OEM

The Rhea is a modular spectrometer. The diversity is almost unlimited. Admesy can configure the Rhea with almost any grating or slit. A large amount of standard gratings and slits are available. Next to that additional detectors will be available in the near future. Please consult our distributor or sales engineers for your specific configuration. For OEM customers we additionally offer customized electrical, mechanical and firmware designs as well as system integration support.

### 5 Rhea general specifications

Rhea	
Non-linearity	<1%
Data output resolution	Selectable 0.5nm, 1nm, 2.5nm, 5nm or 10nm
Focal length	115mm
NA optical bench	0.10
Spectral range	See spectral ranges and FWHM
Order sorting filter	Linear variable filter
Wavelength accuracy	+/- 0.5nm
Stray light	<0.05% (measured @ 400nm with 455nm cut-off filter with broadband light source)
Luminance accuracy	+/-2% (after calibration, compared to cal source)
Chromaticity accuracy	+/- 0.0015 (after calibration, compared to cal source)
Detector	High end Hamamatsu cooled detector (S7031)
Dark noise (RMS)	~ 3 to 5 counts (16 bit ADC)
S/N*	>1300:1
Filter wheel	OD1, OD2, OD3, OD4, open and shutter function
Integration time	4.8ms – 60 minutes
Cooling temperature	-10°C
Interfaces	High speed USB, RS232, Ethernet, Trigger connections
Measurement parameters	Spectral output, radiometric data or colour data (Lumen, x,y, DWL, PWL, CRI, CCT, etc.)
Data processing time	15ms
Size (LxWxH)	230 x 195 x 82.5mm (without optical system)
Weight	3.3kg
Operating temperature	10-35°C
Power input	Typical 15V DC (14.5-15.5V DC range)
Power consumption	Typical 12W. Max 30W
Fiber connection	SMA or M8

*Note: \*S/N is calculated at peak wavelength (almost full saturation) with 100 spectral measurements. Calculation method: average divided by standard deviation.*



## 6 Rhea at a glance

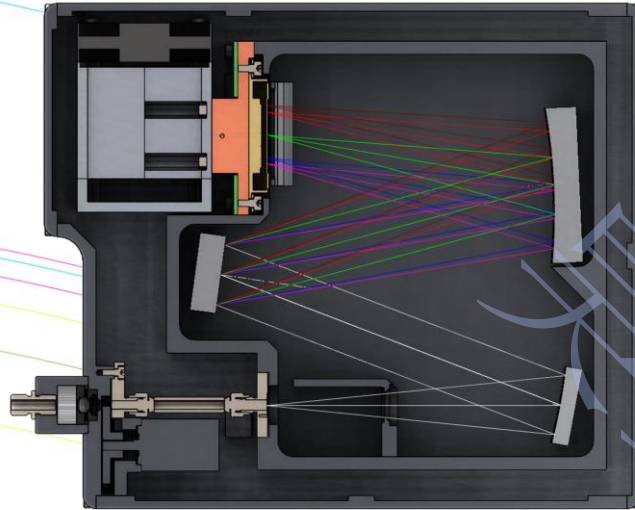

The Rhea spectrometer has a Czerny-Turner configuration. The optical bench consists of a slit, a mirror, a grating, a second mirror, a collector lens, a linear variable filter (OSF) and a cooled detector. In front of the optical bench a filter wheel with ND filters is located. Additional components (fiber, lens) are used to improve total system performance.

### 6.1 System response

The system response is mainly determined by the grating and the detector response. In the next chapter you can see the system response for each grating. In the system response we have included the detector, grating and the mirrors. This data is based on simulation data and is only meant for realistic indication purposes. System response data can be found in the following chapter.

### 6.2 Detector

The Rhea uses cooled CCD detectors from Hamamatsu. Currently the Rhea supports detectors for the range of 200-1100nm.

Quantum efficiency of the detector is illustrated in the following graph.

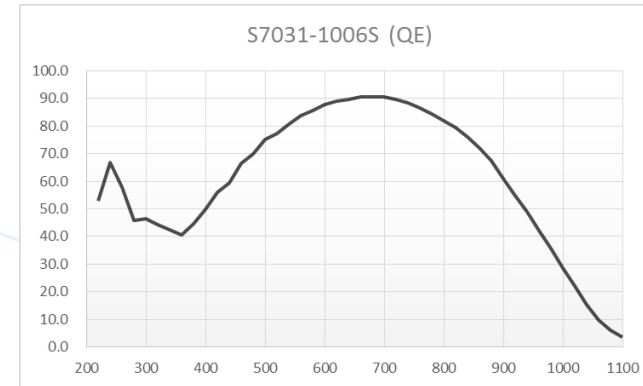

### 6.3 Slit size

The slit size defines the amount of light entering the optical bench. The Rhea can be configured with various slit sizes. The slit size influences the FWHM.

### 6.4 Gratings

The grating disperses the light into individual wavelengths. The amount of dispersion is determined by the number of grooves. The blaze wavelength determines the optimal efficiency at a certain wavelength. Admesy keeps on extending its stock of gratings. If a grating is not on the list or you require something different please contact our distributor or sales engineers to see what the possibilities are.



### 6.5 Dispersion range

The higher the number of grooves the wider the dispersion. However, this also limits the range of wavelengths which can be resolved because the detector has a fixed width. For a broad wavelength range low groove gratings can be used and for a detailed analysis of a small wavelength range high grooves gratings can be used. This range is defined as the dispersion range. The number of grooves also has influence on the FWHM.

### 6.6 Filter wheel

The Rhea contains a filter wheel with 4 ND filters (OD1, OD2, OD3 and OD4) to enable a huge dynamic range. The fifth and sixth position on the filter wheel are for fully open and close. Each ND filter is fully calibrated so no spectral difference is visible between ND filter wheel positions.

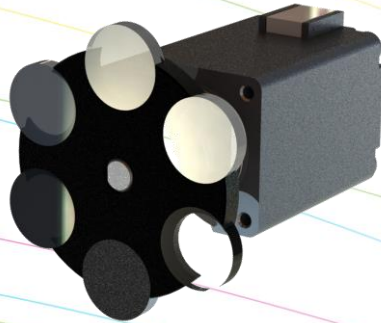

### 6.7 Start and stop wavelength

Start and stop wavelength are depending on the grating choice and alignment. For example, a grating with a dispersion range of 200nm can be used from 300nm to 500nm as well as from 400nm to 600nm. In order to keep every system the same we have also implemented a start and stop wavelength. These start and stop wavelengths are defined by an additional configuration order code which, combined with the Rhea order code, ensures that the Rhea is configured with the exact required wavelength range.





## 7 System configuration

The following table describes each grating with its corresponding range. The normalized total system response graphs are included on the next pages for indicative purposes. The Code is specified as the grooves per mm and Blaze wavelength. Both are divided by 10 in the code. Additionally the type of grating can be chosen. H stands for holographic and R for ruled. Currently Admesy supports only holographic gratings.

The following table defines the expected FWHM values for each type of grating (classified by the number of grooves/mm) and the slit size.

Code	Type	Grooves/mm	Blaze wl[nm]	Dispers. range[nm]	Used range
020030H	Hologr.	200	300	900	UV-NIR
030040H	Hologr.	300	400	600	UV-NIR
030060H	Hologr.	300	600	600	VIS-NIR
030100H	Hologr.	300	1000	600	VIS-NIR
050030H	Hologr.	500	300	350	UV-NIR
060030H	Hologr.	600	300	300 - 280	UV-NIR
060060H	Hologr.	600	600	300 - 280	VIS-NIR
060100H	Hologr.	600	1000	300 - 280	VIS-NIR
090030H	Hologr.	900	300	200 - 150	UV-NIR
090060H	Hologr.	900	600	200 - 150	VIS-NIR
090080H	Hologr.	900	800	200 - 150	VIS-NIR
120020H	Hologr.	1200	200	150 - 90	UV-NIR
120040H	Hologr.	1200	400	150 - 90	UV-NIR
120080H	Hologr.	1200	800	150 - 90	VIS-NIR
160020H	Hologr.	1600	200	100 - 30	UV-NIR
160060H	Hologr.	1600	600	100 - 30	VIS-NIR
180040H	Hologr.	1800	400	90 - 25	UV-NIR

FWHM [nm] S7031-1006 detector (1024 pixels)				
Grating G/mm	100um	50um	25um	10um
200	3.7	2.7	2.4	2.3
300	2.6	1.8	1.6	1.5
500	1.5	1.1	0.95	0.85
600	1.3	0.9	0.8	0.7
900	0.90-0.65	0.60-0.45	0.55-0.40	0.45-0.36
1200	0.68-0.40	0.45-0.27	0.40-0.24	0.32-0.19
1600	0.45-0.14	0.30-0.10	0.26-0.08	0.21-0.06
1800	0.41-0.12	0.27-0.08	0.24-0.07	0.19-0.05

Note: FWHM values are approximations.

Note: Double values are for lower and higher wavelengths.

The following chapters describe the system response (grating + detector + mirrors), they are purely for indication and can differ slightly.

Note: Small deviations can occur for the dispersion range.

Note: Double values at the dispersion range define the ranges for low and high wavelengths.

Note: Combine this data with the system response graphs to check whether your required range is feasible with respect to the total spectral system efficiency.

Note: The dispersion range includes a safety margin.



### 7.1 200 grooves system response

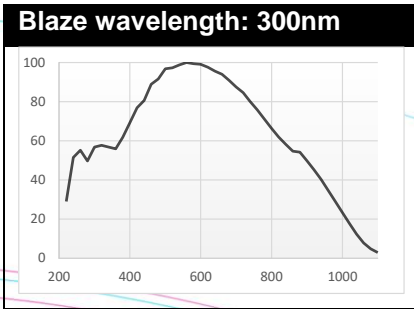

### 7.2 300 grooves system response

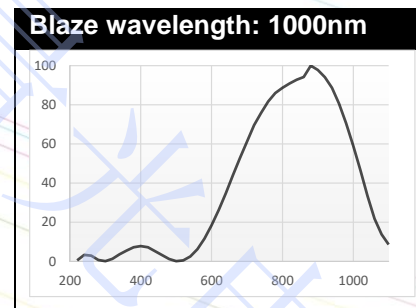
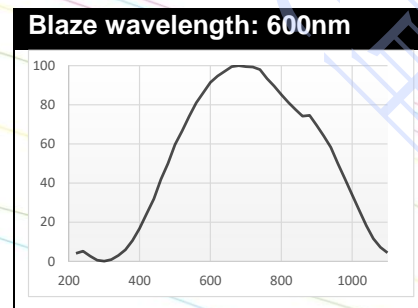
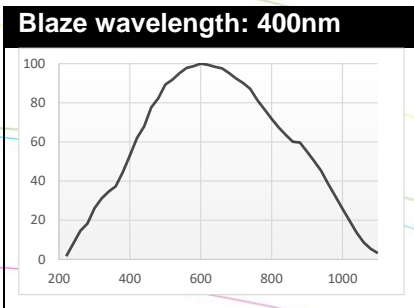

### 7.3 500 grooves system response

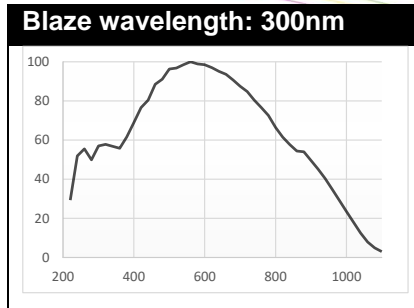





### 7.4 600 grooves system response

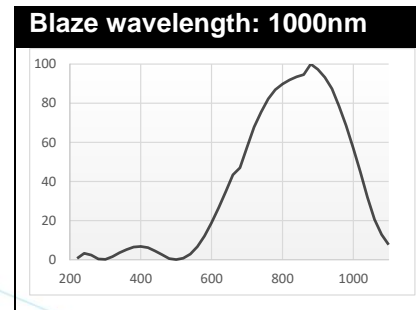
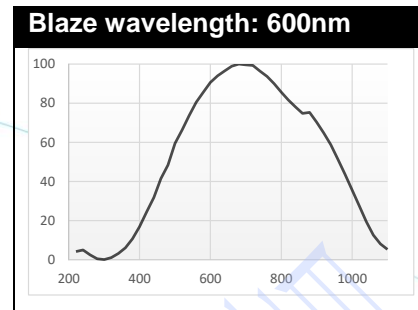
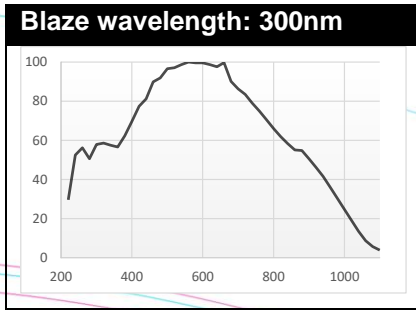

### 7.5 900 grooves system response

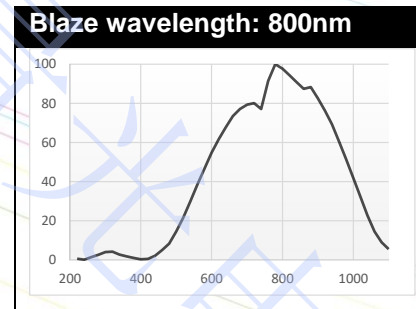
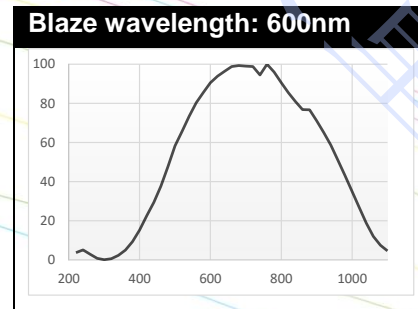
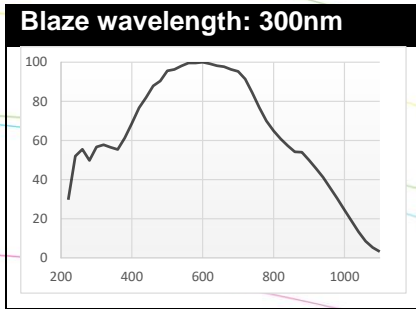

### 7.6 1200 grooves system response

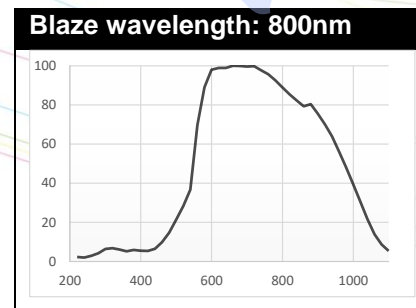
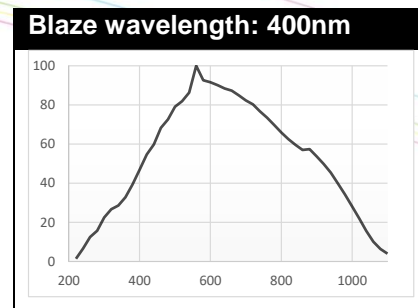
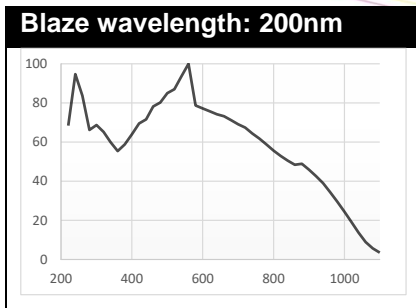



### 7.7 1600 grooves system response

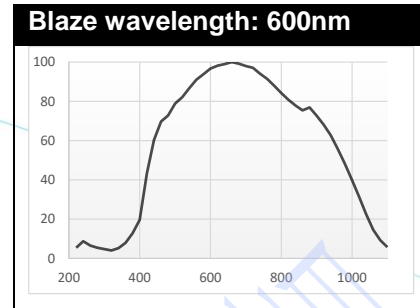
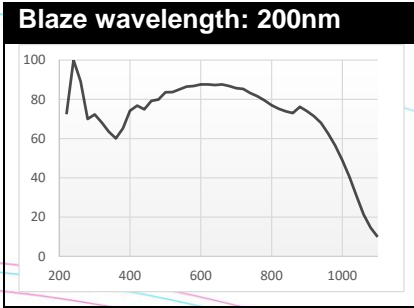

### 7.8 1800 grooves system response

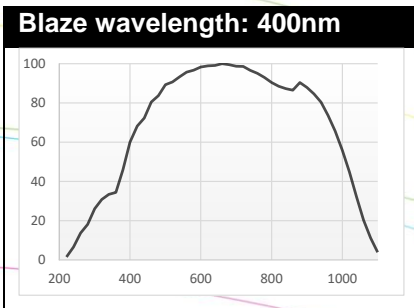



## 8 System performance

Admesy believes in providing its customers with plug and play solutions. Therefore, several compensations are done inside each single spectrometer before it is shipped out.

### 8.1 Dark current

We use a sophisticated dark current software compensation algorithm inside the spectrometer to make sure that the user does not have to compensate for dark current himself when using the device in normal conditions. Normal measurement commands do not (end need not) include a dark level subtraction. In extreme circumstances such as very low light levels or very long integration times, subtracting a dark current measurement could improve measurement accuracy.

Admesy checks all Rhea spectrometer on the performance of dark. In our factory this item is tested in “raw” mode. In the case raw 16-bit ADC data is checked.

### 8.2 Non-linearity

The non-linearity of a spectrometer is defined by the mismatch in the correlation between the actual amount of light and the resulting measurement value. Theoretically when the amount of light is doubled the spectrometer output should also double. Admesy calibrates for mismatches in linearity.

### 8.3 Wavelength calibration

Each spectrometer is calibrated using a monochromator guaranteeing the highest possible wavelength accuracy level.

### 8.4 Stray light

Stray light measurements are done with a halogen light source and a FGL455 cut-off filter, relative to the peak intensity of the unweighted spectral data. Measurement point is at 400nm.

### 8.5 Absolute calibration

Admesy offers NIST traceable calibration services for irradiance and radiance.

### 8.6 Spectrometer output

Spectrometer output from the Rhea is compensated/calibrated for the following items:

- Wavelength
- Dark current
- Non-linearity
- ND filter
- Absolute calibration (optional)

Internally the output is divided by the integration time. So the output value does not change when the integration time is changed. This is correct since the integration time is no parameter for the amount of light.

### 8.7 Production

Each item above is checked and logged during production. We take pride in producing each spectrometer to meet and exceed device specifications.





## 9 Order codes

The Rhea order code system consists of 2 parts:

- Rhea system order code: defines the hardware configuration.
- Rhea configuration order code: defines the start and stop wavelengths.

### 9.1 Rhea system order code

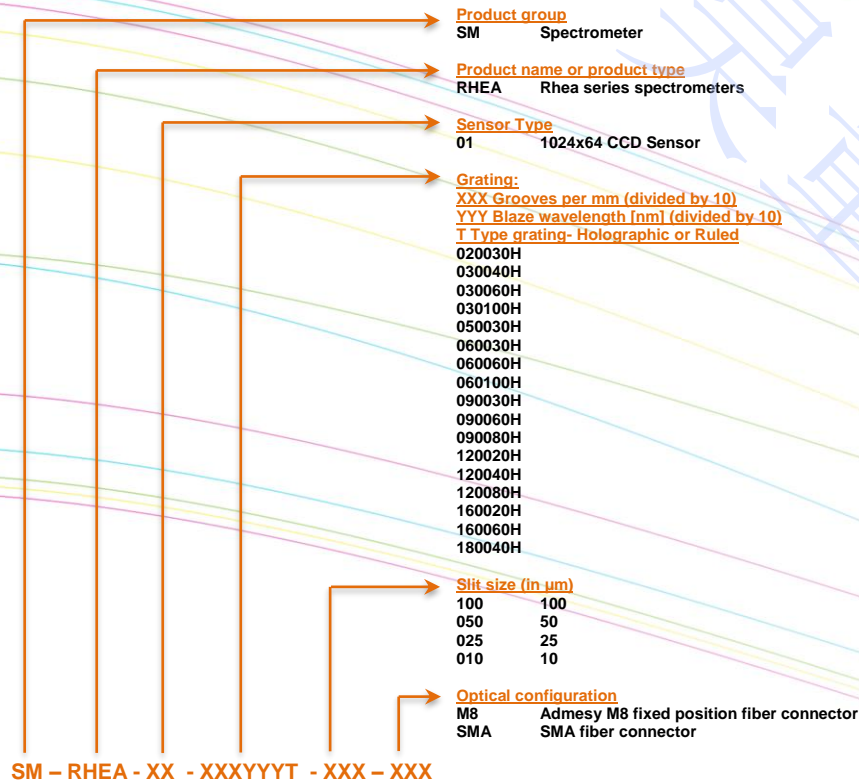

### 9.2 Rhea configuration order code

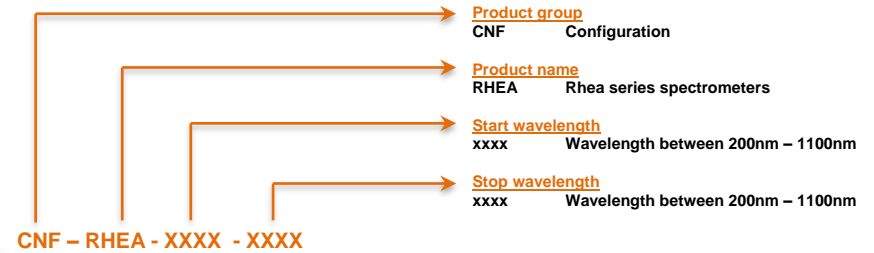

### 9.3 Rhea order code example

Rhea spectrometer with a 1024x64 CCD sensor, a holographic 200 grooves/mm grating with a blaze wavelength of 300nm, a 100μm slit and an SMA connector. Wavelength starting at 260 nm and ending at 1060nm.

**SM - RHEA - 01 - 020030H - 100 - SMA**

**CNF - RHEA - 0260 - 1060**



## 10 Pre-configured spectrometers

Below several popular Rhea configurations are described.

### 10.1 Colour measurement

*Configuration:* A holographic grating with 300 grooves/mm and a blaze wavelength of 400nm, a 1024x64 pixel CCD detector and a slit size of 100 $\mu$ m (FWHM of  $\sim$ 2.6nm). The wavelength range is from 300-900nm. Choose your own connection (M8 or SMA).

*Usage:* colour measurements, irradiance and radiant power within and just beyond the visible range.

Order code:

SM – RHEA – 01 – 030040H – 100 – SMA/M8

CNF – RHEA – 0300 – 0900

### 10.2 Broadband measurement

*Configuration:* A holographic grating with 200 grooves/mm and a blaze wavelength of 300nm, a 1024x64 pixel CCD detector and a slit size of 50 $\mu$ m (FWHM of  $\sim$ 2.7nm). The wavelength range is from 200-1100nm. Choose your own connection (M8 or SMA).

*Usage:* almost any application, like fluorescence, irradiance, absorption etc.

Order code:

SM – RHEA – 01 – 020030H – 050 – SMA/M8

CNF – RHEA – 0200 – 1100

### 10.3 Raman 785nm

*Configuration:* A holographic grating with 600 grooves/mm and a blaze wavelength of 1000nm, a 1024x64 pixel CCD detector and a slit size of 10 $\mu$ m (FWHM of  $\sim$ 0.65nm). The wavelength range is from 785-1050nm. Choose your own connection (M8 or SMA).

*Usage:* measurement with Raman shift up to  $\sim$ 3200 $\text{cm}^{-1}$ , resolution  $\sim$ 8 $\text{cm}^{-1}$  at 900nm.

SM – RHEA – 01 – 060100H – 010 – SMA/M8

CNF – RHEA – 0785 – 1050

### 10.4 Raman 532nm

*Configuration:* A holographic grating with 1200 grooves/mm and a blaze wavelength of 400nm, a 1024x64 pixel CCD detector, a slit size of 10 $\mu$ m (FWHM of  $\sim$ 0.3nm). The wavelength range is from 532-660nm. Choose your own connection (M8 or SMA).

*Usage:* measurement with Raman shift up to  $\sim$ 3600 $\text{cm}^{-1}$ , resolution  $\sim$ 8 $\text{cm}^{-1}$  at 612nm.

SM – RHEA – 01 – 120040H – 010 – SMA/M8

CNF – RHEA – 0532 – 0660

### 10.5 Laser analysis

*Configuration:* A holographic grating with 1600 grooves/mm and a blaze wavelength of 600nm, a 1024x64 pixel CCD detector and a slit size of 10 $\mu$ m (FWHM of  $\sim$ 0.15nm). The wavelength range is from 760-810nm. Choose your own connection (M8 or SMA).

*Usage:* high resolution measurement of laser, in this example 785nm laser.

SM – RHEA – 01 – 160060H – 010 – SMA/M8

CNF – RHEA – 0760 – 0810



## 11 Rhea dimensions

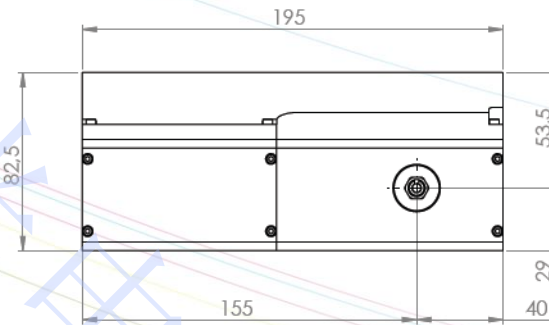
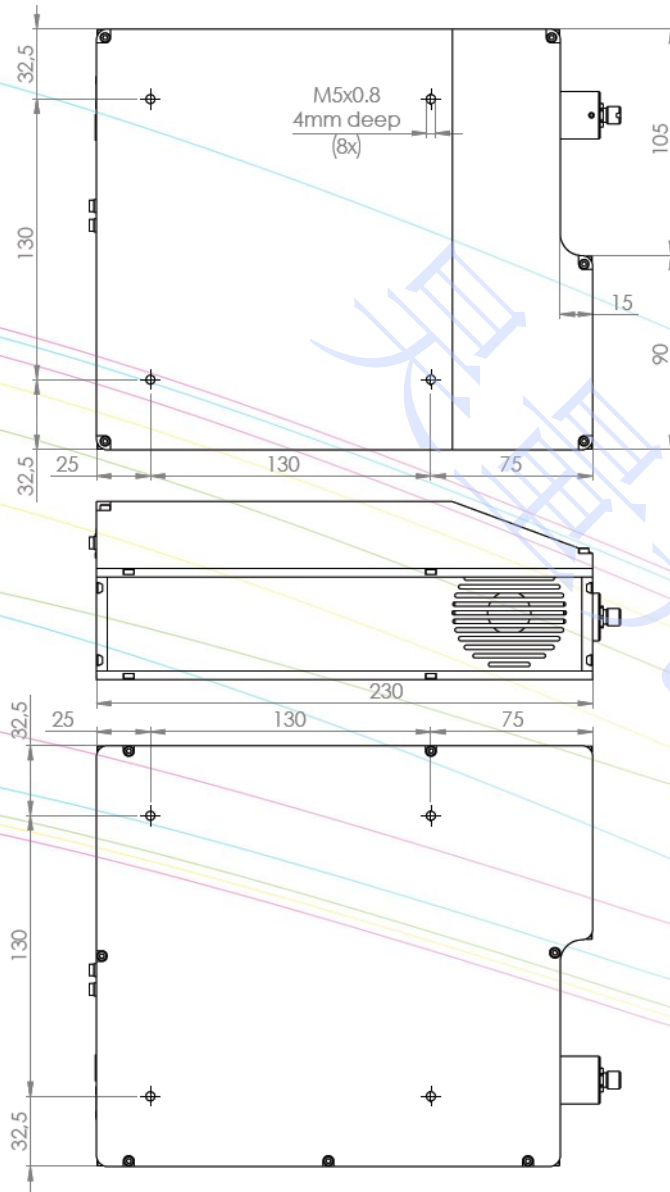





昊量光电

Admesy B.V.  
Sleestraat 3  
6014 CA Ittervoort  
The Netherlands

T +31 (0)475 600 232  
F +31 (0)475 600 316

www.admesy.com  
info@admesy.com

**Aunion Tech Co.,Ltd**

**1850-166-2513 021-510-83793**

**[info@auniontech.com](mailto:info@auniontech.com) [www.auniontech.com](http://www.auniontech.com)**

The material in this document is subject to change. No rights can be derived from the content of this document. All rights reserved. No part of this document may be reproduced, stored in a database or retrieval system, or published in any form or way, electronically, mechanically, by print, photo print, microfilm or any other means without prior written permission from the publisher.