



## CMOS相机 - 技术规格 -

相机型号	CinCam CMOS-1201 标准系列	CinCam CMOS-1202 标准系列	CinCam CMOS-1203 标准系列	CinCam CMOS-1204 标准系列
<b>探测器规格</b>				
口径规格:	1/2"	1/1.8"	1/1.8"	1/2.5"
有效面积:	6.7mm x 5.3mm	6.8mm x 5.4mm	7.2mm x 5.4mm	5.7mm x 4.3mm
像素:	1280 x 1024	1280 x 1024	1600 x 1200	2560 x 1920
像素尺寸:	5.2um x 5.2um	5.3um x 5.3um	4.5um x 4.5um	2.2um x 2.2um
响应波长:				
Standard:	400nm – 1150nm	400nm – 1320nm	400nm – 1320nm	400nm – 1150nm
RT:	320nm – 1150nm	320nm – 1320nm	320nm – 1320nm	320nm – 1150nm
UV:	< 150nm – 1150nm	< 150nm – 1150nm	< 150nm – 1150nm	< 150nm – 1150nm
OM:	-	240nm – 1150nm	240nm – 1150nm	-
IR:	400nm – 1150nm + 1470nm – 1605nm	400nm – 1150nm + 1470nm – 1605nm	400nm – 1150nm + 1470nm – 1605nm	400nm – 1150nm + 1470nm – 1605nm
光斑直径min/max (推荐的):	52um / 4mm	53um / 4.1mm	45um / 4mm	22um / 3.2mm
<b>相机特性</b>				
安装接口	F-Mount	F-Mount	F-Mount	F-Mount
位深:	8Bit	8Bit	8Bit	8Bit
动态范围:	68dB	62dB	62dB	70dB
帧频:	up to 20Hz	up to 20Hz	up to 14Hz	up to 5Hz
供电接口:	USB 2.0	USB 2.0	USB 2.0	USB 2.0
激光器模式:	连续	连续和脉冲	连续和脉冲	连续
注: CMOS-1201和CMOS-1204也可用于测量脉冲激光器, 但需激光器的重复频率不低于10KHz				
<b>技术规格</b>				
机械尺寸 (W x H x L):	40mm x 40mm x 20mm	40mm x 40mm x 20mm	40mm x 40mm x 20mm	40mm x 40mm x 20mm
重量:	46g	50g	50g	50g
储存温度:	- 10° C ~ + 60° C	- 10° C ~ + 60° C	- 10° C ~ + 60° C	- 10° C ~ + 60° C
操作温度:	- 10° C ~ + 40° C	- 10° C ~ + 40° C	- 10° C ~ + 40° C	- 10° C ~ + 40° C



## CMOS Nano相机 - 技术规格 -

相机型号	CMOS-1201-Nano Nano 系列		CMOS-1.001-Nano Nano 系列	
<b>探测器规格</b>				
口径规格:	1/1.8"		1"	
有效面积:	6.8mm x 5.4mm		11.3mm x 11.3mm	
像素:	1280 x 1024		2048 x 2048	
像素尺寸:	5.3um x 5.3um		5.5um x 5.5um	
响应波长:				
Standard:	400nm – 1320nm		400nm – 1320nm	
RT:	320nm – 1320nm		320nm – 1320nm	
UV:	< 150nm – 1150nm		< 150nm – 1150nm	
OM:	240nm – 1150nm		-	
IR:	400nm – 1150nm + 1470nm – 1605nm		400nm – 1150nm + 1470nm – 1605nm	
光斑直径min/max (推荐的):	53um / 4.1mm		55um / 7.5mm	
<b>相机特性</b>				
安装接口	F-Mount		F-Mount	
位深:	10Bit		10Bit	
动态范围:	62dB		60dB	
帧频:	up to 40Hz (higher on request)		up to 100Hz	
供电接口:	USB 3.0		USB 3.0	
激光器模式:	连续和脉冲		连续和脉冲	
<b>技术规格</b>				
机械尺寸 (W x H x L):	29mm x 29mm x 20mm		29mm x 29mm x 24mm	
重量:	26g		28g	
储存温度:	- 10° C ~ + 60° C	- 10° C ~ + 60° C	- 10° C ~ + 60° C	- 10° C ~ + 60° C
操作温度:	- 10° C ~ + 40° C	- 10° C ~ + 40° C	- 10° C ~ + 40° C	- 10° C ~ + 40° C



## CMOS Pico相机 - 技术规格 -

相机型号	CMOS-1201-Pico	
<b>探测器规格</b>		
口径规格:	1/2.5"	
有效面积:	5.7mm x 4.3mm	
像素:	2560 x 1920	
像素尺寸:	2.2um x 2.2um	
响应波长:		
Standard:	400nm – 1150nm	
RT:	320nm – 1150nm	
UV:	< 150nm – 1150nm	
OM:	240nm – 1150nm	
IR:	400nm – 1150nm + 1470nm – 1605nm	
光斑直径min/max (推荐的):	22um / 3.2mm	
<b>安装接口</b>		
安装接口	F-Mount	
位深:	12Bit	
动态范围:	70dB	
帧频:	up to 4.6Hz (higher on request)	
供电接口:	USB 2.0	
激光器模式:	连续	
注: CMOS-1201-Pico相机也可用于测量脉冲激光器, 但需激光器的重复频率不低于10KHz		
<b>技术规格</b>		
机械尺寸 (W x H x L):	15mm x 15mm x 11.5mm	
重量:	20g	
储存温度:	- 10° C ~ + 60° C	- 10° C ~ + 60° C
操作温度:	- 10° C ~ + 40° C	- 10° C ~ + 40° C



## RayCi-Lite分析软件 - 主要应用以及软件界面 -

### 光斑大小在线调试以及实时测量

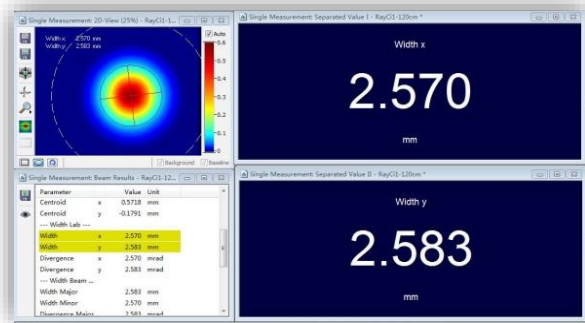

### 发散角的在线调试以及实时测量

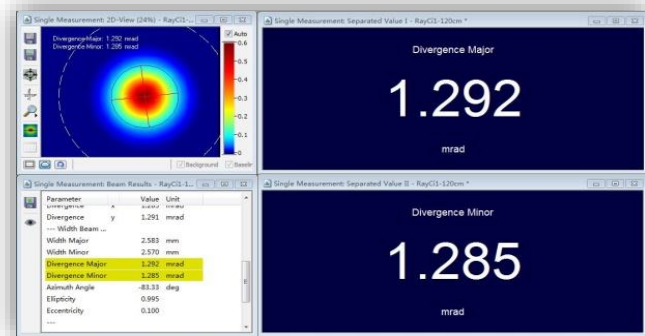

### 光束的位置调试以及校准（重心）

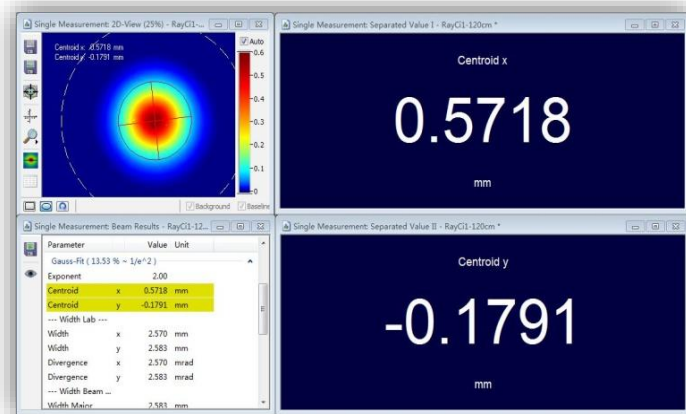

### 以颜色显示不同的光斑尺寸范围（可设置pass/fail）

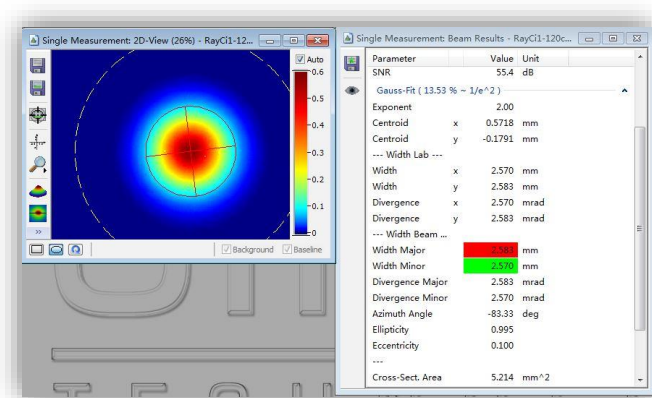

德国CINOGY中国独家代理商：上海昊量光电设备有限公司  
 地址：上海市徐汇区漕宝路86号光大会展中心F座2802室  
 电话：021-51083793      传真：021-34241962-8009  
 邮箱：info@auniontech.com      网站：www.auniontech.com

**AUNION TECH**  
 昊量光电



## RayCi-Lite分析软件 - 主要应用以及软件界面 -

### 功率的实时测量

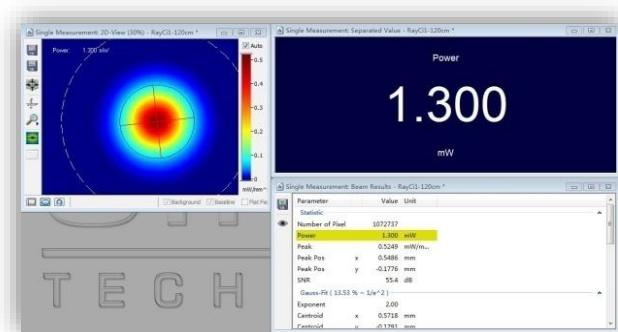

### 椭圆度实时测量

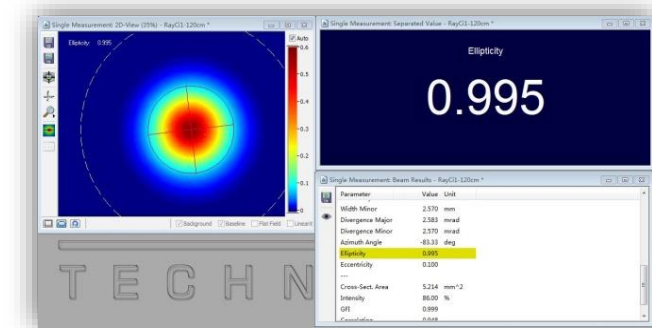

### 二维能量分布测量

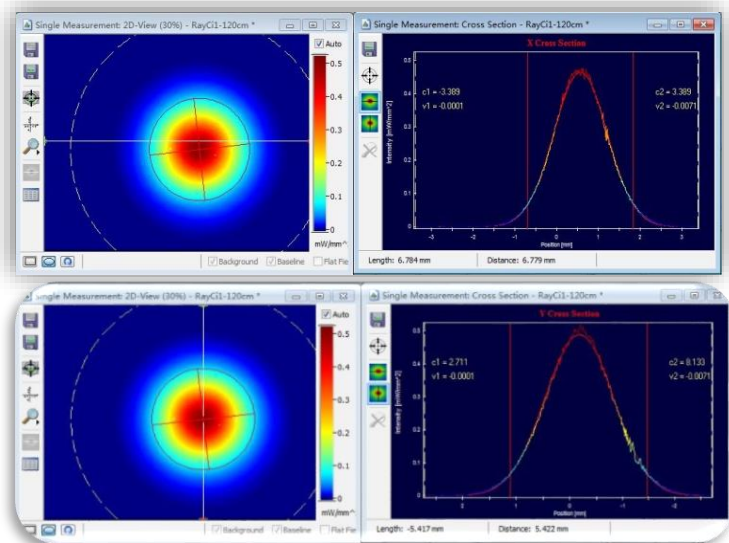

### 多种背景颜色显示

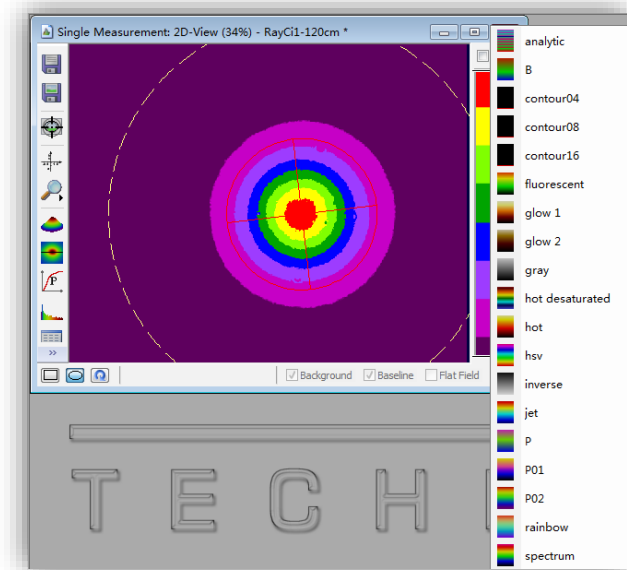

德国CINOGY中国独家代理商：上海昊量光电设备有限公司  
 地址：上海市徐汇区漕宝路86号光大会展中心F座2802室  
 电话：021-51083793 传真：021-34241962-8009  
 邮箱：info@auniontech.com 网站：www.auniontech.com



## CMOS相机

- 响应波长 -
- 机械尺寸 -

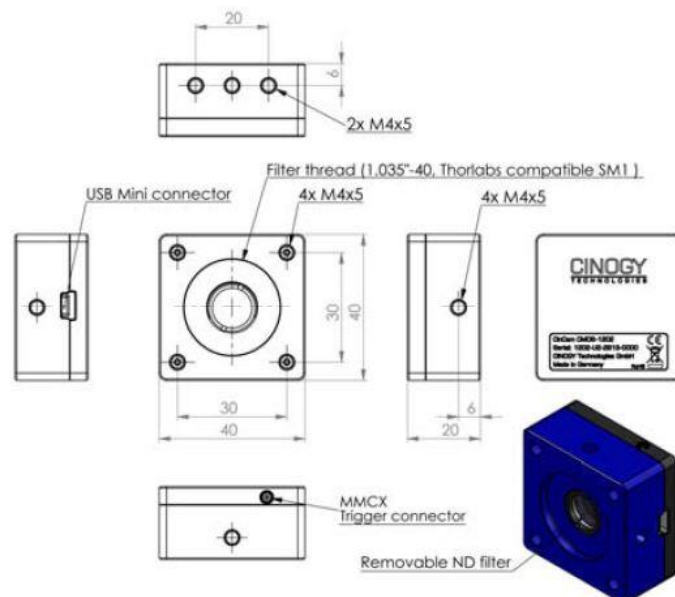
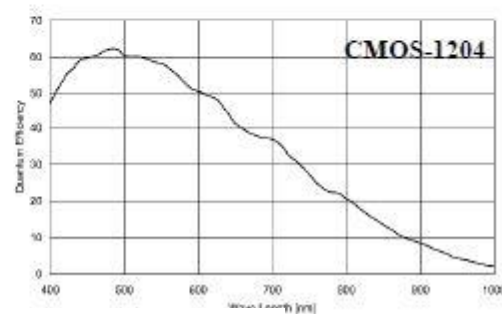
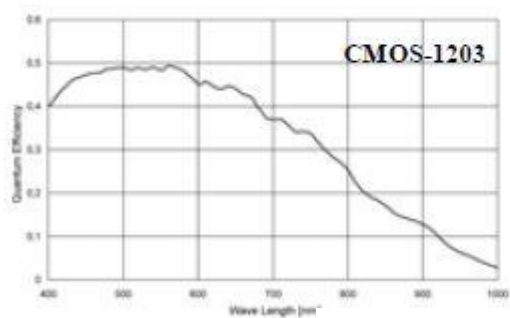
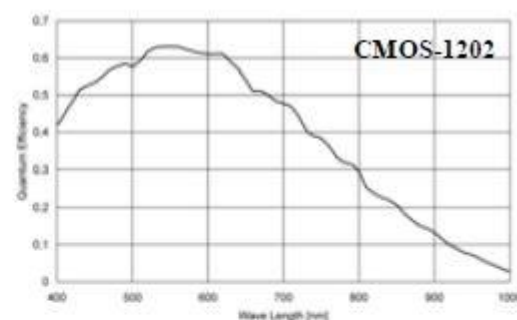
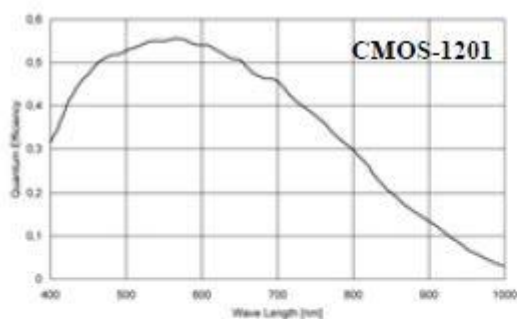

德国CINOGY中国独家代理商：上海昊量光电设备有限公司  
 地址：上海市徐汇区漕宝路86号光大会展中心F座2802室  
 电话：021-51083793      传真：021-34241962-8009  
 邮箱：info@auniontech.com      网站：www.auniontech.com



## CMOS Nano相机

- 响应波长 -
- 机械尺寸 -

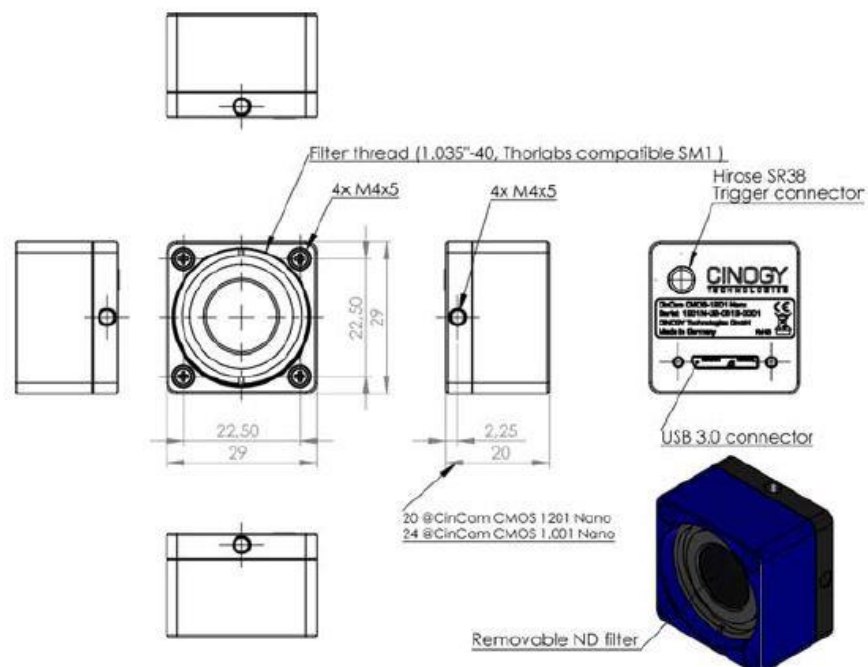
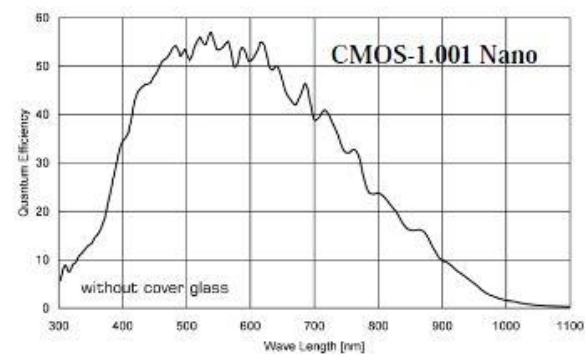
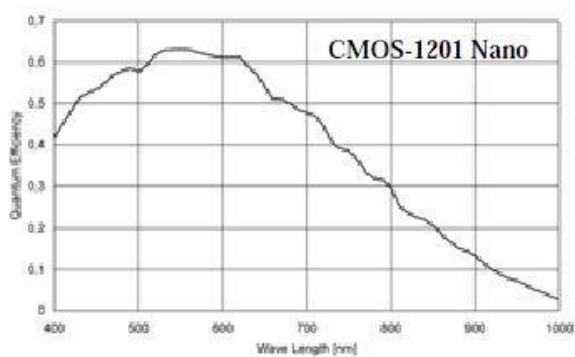

德国CINOGY中国独家代理商：上海昊量光电设备有限公司  
 地址：上海市徐汇区漕宝路86号光大会展中心F座2802室  
 电话：021-51083793      传真：021-34241962-8009  
 邮箱：info@auniontech.com      网站：www.auniontech.com



## CMOS Pico相机

- 响应波长 -

- 机械尺寸 -

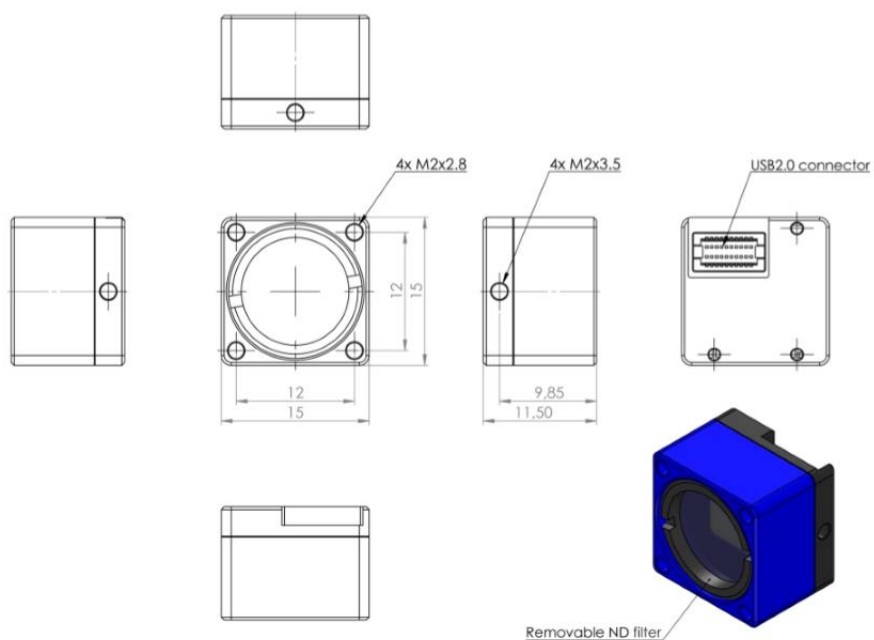
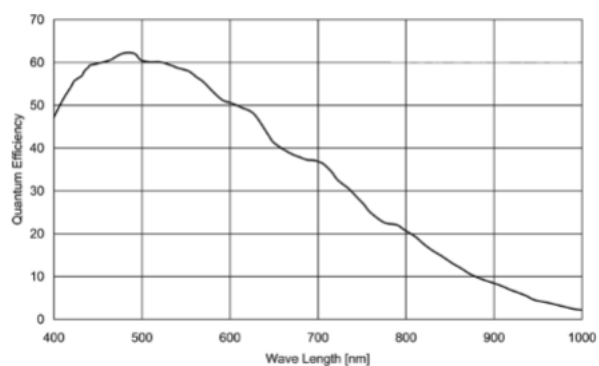

德国CINOGY中国独家代理商：上海昊量光电设备有限公司  
 地址：上海市徐汇区漕宝路86号光大会展中心F座2802室  
 电话：021-51083793      传真：021-34241962-8009  
 邮箱：info@auniontech.com      网站：www.auniontech.com





## CMOS相机 - 操作范围 -

连续激光器功率饱和限制

脉冲能量饱和限制

CinCam CMOS-1201

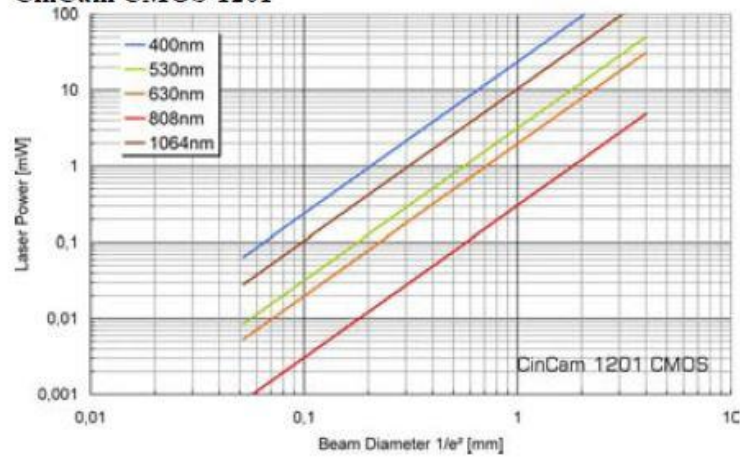

CinCam CMOS-1202

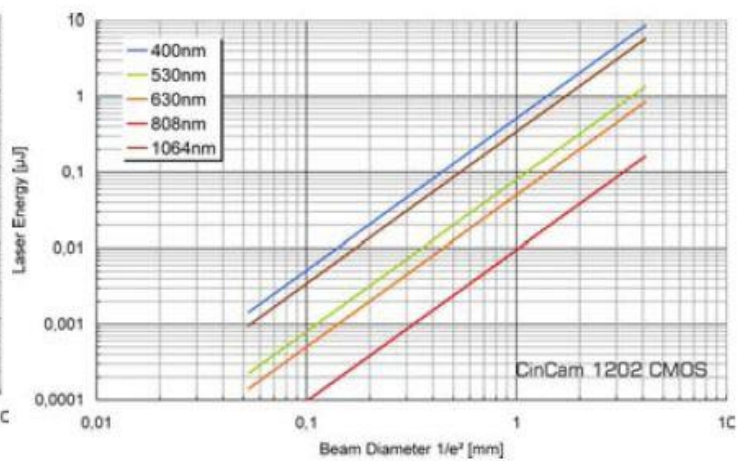
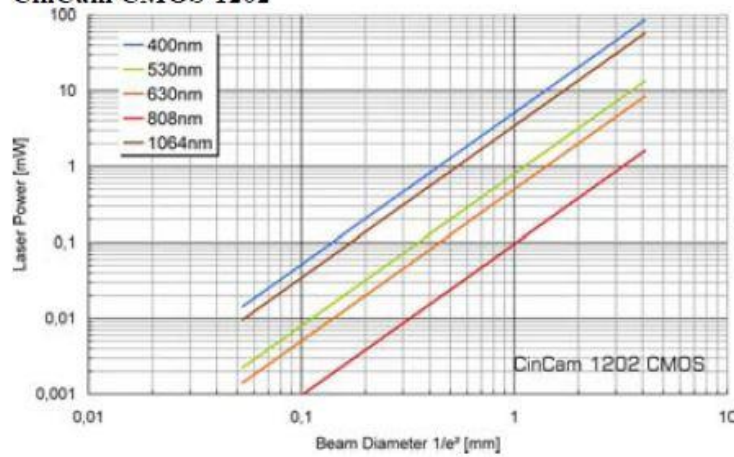

德国CINOGY中国独家代理商：上海昊量光电设备有限公司  
地址：上海市徐汇区漕宝路86号光大会展中心F座2802室  
电话：021-51083793      传真：021-34241962-8009  
邮箱：info@auniontech.com      网站：www.auniontech.com



## CMOS相机 - 操作范围 -

### 连续激光器功率饱和限制

### 脉冲能量饱和限制

CinCam CMOS-1203

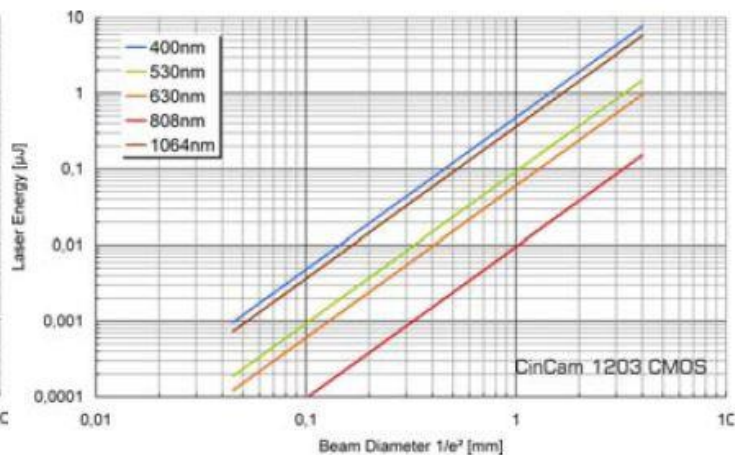
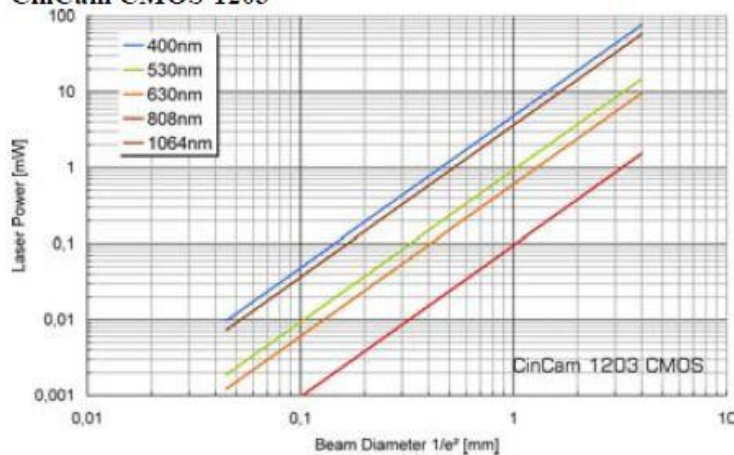

CinCam CMOS-1204

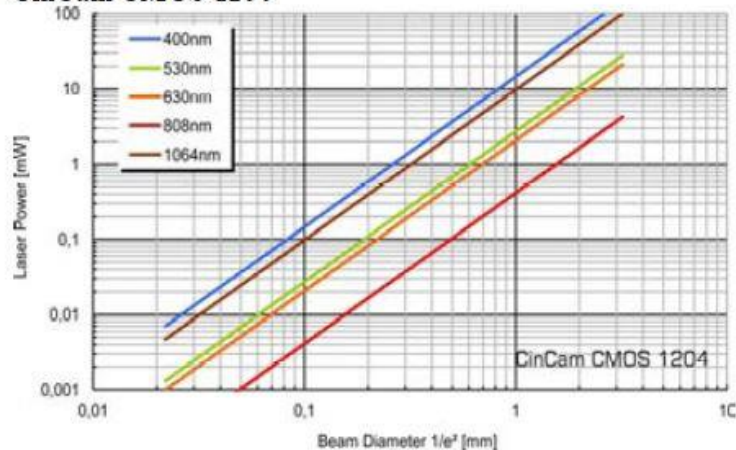



## CMOS Nano相机 - 操作范围 -

### 连续激光器功率饱和限制

### 脉冲能量饱和限制

CinCam CMOS-1201 Nano

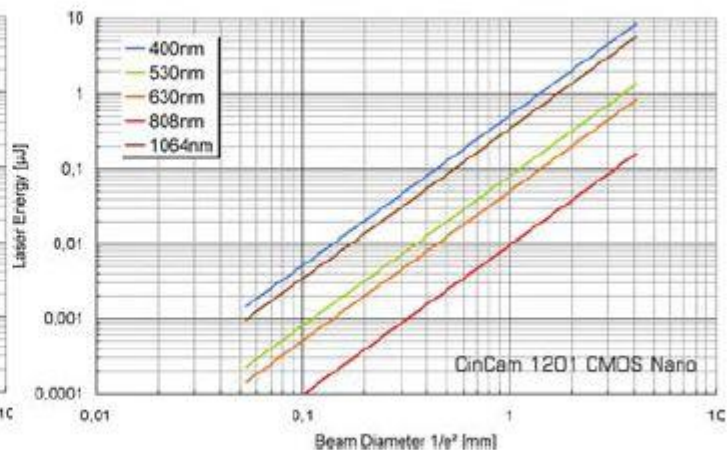
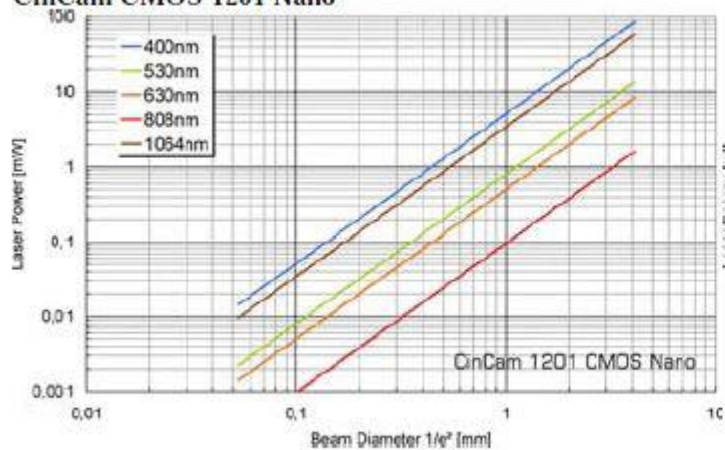

CinCam CMOS-1.001 Nano

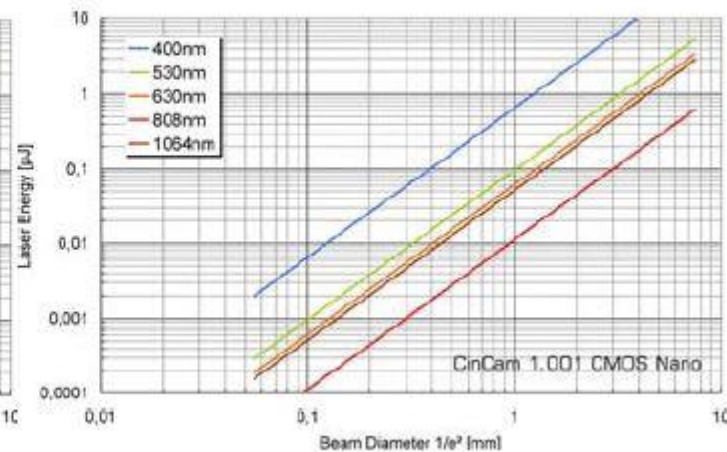
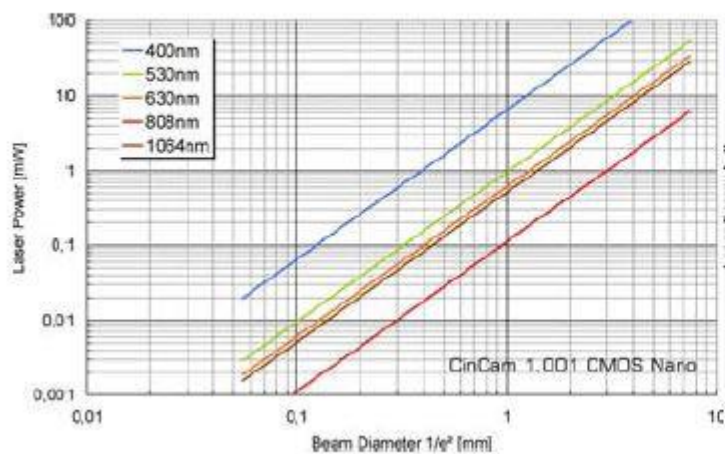



## CMOS Pico相机 - 操作范围 -

### 连续激光器功率饱和限制

CinCam CMOS-1201-Pico

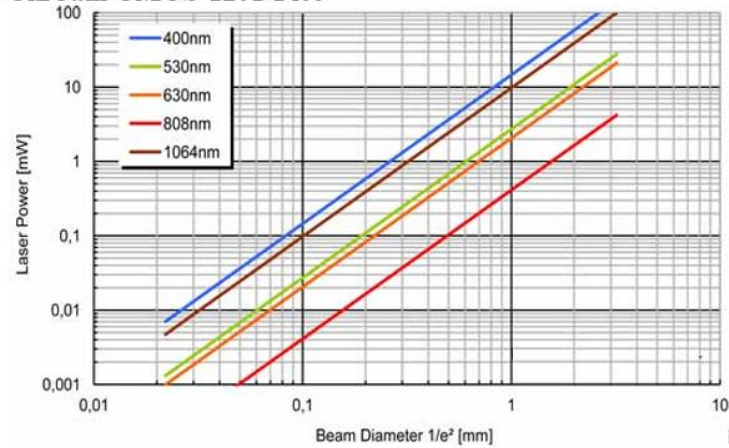



## RayCi-Lite分析软件 - 操作系统 -

XP / Vista / Windows 7
Pentium IV / AMD Processor (Dual / Quad Core)
512MB graphic, Open GL V1.4 (NVIDIA)
2GB RAM
500MB free memory
PCI / PCIe slot
USB ports
CD / DVD-ROM drive
Internet access for update request

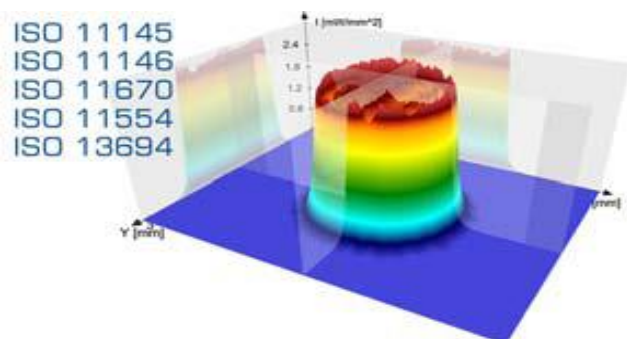

兼容32位和64位的版本系统



## RayCi分析软件 - 功能综述 -

	Lite	Standard	Professional
<b>System</b>			
XP, Vista, Windows 7	32Bit / 64Bit	32Bit / 64Bit	32Bit / 64Bit
<b>Beam Profiler</b>			
Multi-Use (Several Beam Profilers simultaneously)	○	○	●
Support for USB / FireWire / GigE / CameraLink Beam Profiler	●	●	●
CW Mode / Pulse Mode (Software Trigger)	● / ●	● / ●	● / ●
Live Mode (live data) and Save Mode (stored data) can be used simultaneously	●	●	●
Automatic Update Support / Email Support	○ / ●	● / ●	● / ●
<b>Visualization Windows</b>			
2D-View (2D Profile, AOI Features, Beam Width, Cuts, Coordinate System)	●	●	●
3D-View (3D Profile, Coordinate System, Rotation, Cuts, Gauss Fit)	○	●	●
Histogram (Probability Density Distribution, Cursor)	○	●	●
Cross Section (X/Y-Cut, Radial-Cut, Circular-Cut, Arbitrary-Cut, Beam Width, Cursor)	● (X, Y)	● (All)	● (All)
Number of Cross-Section Windows	1	2	2
Cross Section Analysis (1D Beam Width, Edge Steepness)	○	●	●
Beam Results (Highlighting, Separating, Pass / Fail Criteria)	● / ● / ○	● / ● / ●	● / ● / ●
AOI Parameter (Center xy, Diameter, Area, Intensity)	●	●	●
Centroid Position	●	●	●
Statistics (Number of Pixel, Power, Peak)	●	●	●
Beam Parameter (Beam Width, Centroid, Uniformity, etc.)	●	●	●
Beam Profiler Dynamic (Saturation, Intensity, Power)	●	●	●
<b>Measurement Windows (ISO 11146, ISO 13694, ISO 11670)</b>			
Single Measurement (2D / 3D-View, Histogram, Cross Section, Beam Results)	●	●	●
Time Series (2D / 3D-View, Histogram, Cross Section, Beam Results)	○	●	●
Divergence Measurement (2D / 3D-View, Fit, Divergence Parameter)	○	●	●
Beam Quality M <sup>2</sup> Tool (2D / 3D-View, Caustic Fit, 3D Caustic Fit, Caustic Parameter)	○	○	●
Beam Stability (Peak, Power, Centroid X/Y, Beam Width: d, D, Phi)	○	●	●
Pointing Stability (Centroid Fluctuation X/Y, Centroid Position Analysis, Spectrum)	○	●	●
<b>Standard Features</b>			
LUT	●	●	●
Adjustable LUT Dynamic	●	●	●
Automatic Contrast Function	●	●	●
AOI Tracking (Centroid, Peak, Beam Width)	●	●	●
Spatial Units (px, μm, mm, cm, in, m)	●	●	●
Power Units (1, nW, μW, mW, W, kW)	●	●	●
Coordinate System (Default, Standard, User-Defined)	●	●	●
Adjustable Cursors (Peak, Beam Width, Edge Steepness)	○	●	●
Zoom Function (All Visualization and Measurement Windows)	●	●	●
Camera Settings (Exposure Time, Gain, Floating Average, Frame Summing)	●	●	●
Trigger Settings (Polarity, Delay Time, Auto Pulse Finder)	●	●	●
Measure Types (Max Speed, Max Calculation)	● / ○	● / ●	● / ●

● included    ○ not included

德国CINOGY中国独家代理商：上海昊量光电设备有限公司  
 地址：上海市徐汇区漕宝路86号光大会展中心F座2802室  
 电话：021-51083793      传真：021-34241962-8009  
 邮箱：info@auniontech.com      网站：www.auniontech.com

**AUNION TECH**  
昊量光电



## RayCi分析软件 - 功能综述 -

	Lite	Standard	Professional
<b>Correction and Calibration Tool</b>			
Background Correction (incl. Cold and Hot Pixel)	•	•	•
Offset Correction (base line correction)	•	•	•
Flat Field Calibration	•	•	•
Linearity Calibration	◦	•	•
Power Calibration	•	•	•
<b>2D Beam Width Techniques</b>			
Threshold	•	•	•
2 <sup>nd</sup> Moment	•	•	•
Gauss-Fit	•	•	•
Super-Gauss-Fit	◦	•	•
Plateau	◦	•	•
Geometry Simple	◦	•	•
Geometry Area	◦	◦	•
Knife-Edge 90/10	•	•	•
Moving Slit 86/14	◦	•	•
<b>2D Beam Parameters</b>			
Exponent	◦	•	•
Centroid at x, y	•	•	•
Beam width at x, y / Divergence at x, y (Lab Coordinates)	•	•	•
Beam width major, minor / Divergence major, minor (Beam Coordinates)	•	•	•
Azimuth Angle	•	•	•
Ellipticity / Eccentricity	•	•	•
Correlation	•	•	•
Uniformity	•	•	•
Roughness	◦	•	•
Slope	◦	•	•
Cross-Sectional Area	•	•	•
Intensity	•	•	•
Goodness of Fit Index (GFI)	•	•	•
Top Hat Factor (F)	◦	•	•
Effective Power	•	•	•
Power Ratio	•	•	•
Effective Area	•	•	•
Mean Intensity	•	•	•
Flatness	•	•	•
Edge Steepness	•	•	•
<b>Beam Statistics</b>			
Number of Pixel	•	•	•
Power	•	•	•
Peak at x, y	•	•	•
Centroid at x, y	•	•	•

• included    ◦ not included

德国CINOGY中国独家代理商：上海昊量光电设备有限公司  
 地址：上海市徐汇区漕宝路86号光大会展中心F座2802室  
 电话：021-51083793                      传真：021-34241962-8009  
 邮箱：info@auniontech.com          网站：www.auniontech.com

**AUNION TECH**  
昊量光电



## RayCi分析软件 - 功能综述 -

	Lite	Standard	Professional
<b>Video</b>			
Video capturing	○	●	●
Video playback	○	●	●
Almost all measurements / visualizations can be performed on video files	○	●	●
<b>Work with Live Data / Save Data</b>			
Camera Options (Binning 1x1, 2x2, 4x4, 8x8)	●	●	●
Arithmetic Operations (Add, Subtract, Multiply, Divide, Raise)	●	●	●
Image Transformation (Flip vertical / horizontal, Rotate Left / Right)	●	●	●
Filter (Median, Smoothing, Lowpass, Highpass)	●	●	●
Optimization (AOI Adjustment, AOI Tracking)	○	●	●
<b>Data (Save / Open)</b>			
Single Measurement (TIF / Printable Protocol)	● / ○	● / ●	● / ●
Time Series (TS / Printable Protocol)	○ / ○	● / ●	● / ●
Divergence Measurement (DVG / Printable Protocol)	○ / ○	● / ●	● / ●
Beam Quality (M2 / Printable Protocol)	○ / ○	○ / ○	● / ●
Beam Stability (BST / Printable Protocol)	○ / ○	● / ●	● / ●
Pointing Stability (PST / Printable Protocol)	○ / ○	● / ●	● / ●
<b>Export</b>			
Data (TXT / CSV)	●	●	●
Image (BMP / JPEG / GIF / TIFF / PNG)	●	●	●
Grayscale Image 8Bit (BMP / GIF / TIFF / PNG); 16Bit (PGM)	○	●	●
Video (AVI / TS)	○	●	●
<b>Import</b>			
Data (CSV)	○	○	●
Grayscale Image (BMP / JPEG / GIF / TIFF / PNG / EMF / WMF / ICO)	○	○	●
<b>XML interface that allows full remote control of all RayCi functions</b>			
Control of all camera settings	○	●	●
Capture of data and results	○	●	●
Control of measurement settings	○	●	●
<b>SDK</b>			
Wrapper-Dll for C (LabView)	○	●	●
Wrapper-Dll for .NET	○	●	●
<b>Control of External Devices</b>			
Translation Stage for Beam Quality M <sup>2</sup> - CinSquare	○	○	●
Trigger Device for Advanced Pulse Measurements	○	○	●
Dongle Network Server	○	●	●

● included    ○ not included

德国CINOGY中国独家代理商：上海昊量光电设备有限公司  
 地址：上海市徐汇区漕宝路86号光大会展中心F座2802室  
 电话：021-51083793                      传真：021-34241962-8009  
 邮箱：info@auniontech.com          网站：www.auniontech.com