

BIBO1 / BIBO2

5 GHz Electronic Multiplexers

FEATURES

- Fully Electronic Multiplexers (No Relays)
- 9 Channels (BI301) or 18 Channels (BI302)
- Each 9-Channel Set Consists of One 9:1 or Two 5:1 Multiplexers
- DC to 5 GHz Frequency Range
- Single-Ended or Differential Inputs (Factory-Set)
- Comparator Inputs with Programmable Thresholds and Termination Voltages
- Differential Outputs Drive 50 Ohm Loads to Ground
- PXI Interface – Single Slot (Legacy or Hybrid)

Unique Comparator Inputs

The BI301/BI302 are 9/18-Channel electronic MUXs with comparator inputs. The inputs can be defined to be single-ended or differential, and have programmable threshold levels and termination voltages. The input signals can be square waves or any other waveform. The output edges are based on the threshold crossings of the input signal.

These multiplexers are specifically designed for the highest performance, with very low added jitter. The operating frequency range is DC to 3.5 GHz with full output amplitude of 500 mV, and 5 GHz with reduced amplitude of 200 mV.

The simplified block diagram shows the structure of a 9-channel MUX. The BI301 consists of one 9-channel MUX, while the BI302 has two completely independent 9-channel MUXs. Both models occupy only one PXI slot (legacy or hybrid).

Each channel pair is two single ended channels, or one differential channel. The configuration is set in the factory as ordered. You can order any combination of single ended or differential pairs. Note that a differential pair can still be used with single ended signals if the other input is disconnected. The V_t of the unused side becomes the threshold. The 9th channel (Ch-8) is single ended only and it connects to both 5:1 MUXs. It can be used as a reference channel since any channel can be measured against it.

The outputs from each of the MUXs (A, B, and C) are differential but you can use one side only with other single ended instruments. All input and output connectors are SMP type, compatible with cables ranging from 0.047" to 0.100" diameter.

Full-Featured Instruments

The inputs of the BI301/BI302 include programmable termination voltages. This feature is seldom found even in the best of the bench-top instruments. Each input signal is terminated by a 50 ohm load to an accurately programmable voltage between -2.0 V and +3.0 V. This allows you to connect ECL, PECL, or CML sources directly to the instruments with the proper loading and without level shifting.

Easy to Use Software

The software for the BI301/BI302 is designed for ease of use and extremely high performance. The driver software (Windows and Linux) is designed for high throughput operations. Calibration software is also included.

APPLICATIONS

- Clocks and oscillators
- Signal selection for increasing channel count in test systems
- Level detection and conversion of signals to square waves
- Switching and multiplexing of high speed serial signals



BI301 9-Channel Multiplexer



BI302 18-Channel Multiplexer

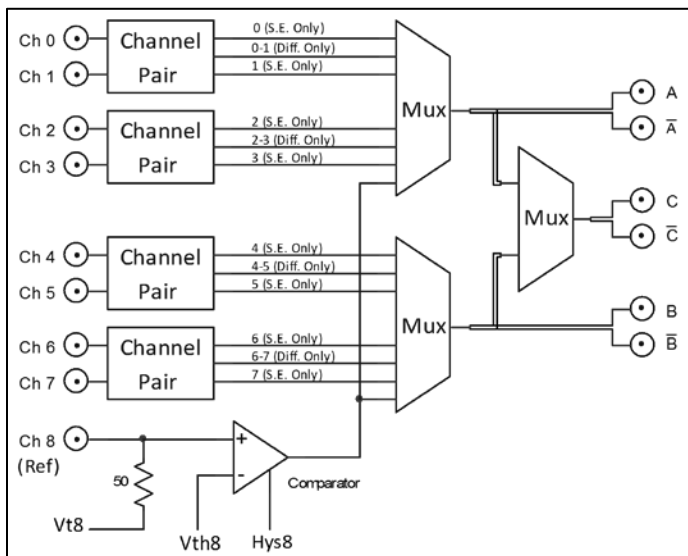

Simplified Block Diagram, One 9-Channel Mux

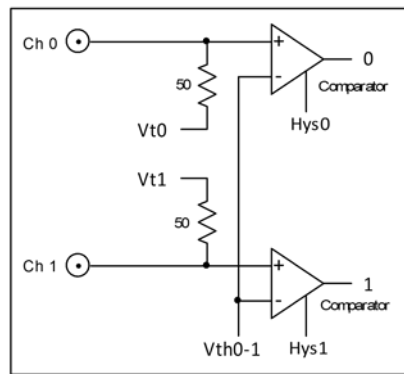

Single-Ended Channel Pair

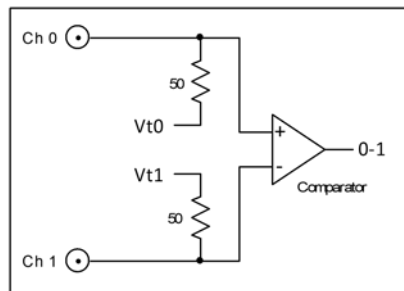

Differential Channel Pair

SPECIFICATIONS

General

- See “Definitions” below for explanation of the terms in the specifications
- Added jitter:
 - ♦ Square wave input: <2 ps
 - ♦ Sine wave input:
 - Frequency > 100 MHz: 2 ps
 - Frequency < 100 MHz: 2 ps + TriggerErr
- Warranty: 1 year

Inputs – Ch 0 to Ch 8

- Frequency range: DC to 5 GHz
- Minimum pulse width: 100 ps
- Coupling: DC
- Input impedance: 50 Ω into a user programmable termination voltage
- Termination voltage (Vt): -2.0 V to +3.0 V (see restrictions below)
 - ♦ Each channel has its own Vt
 - ♦ Resolution: 100 μV
 - ♦ Accuracy: 6 mV
- Trigger threshold voltage (Vth): -3.0 V to +5.0 V (see restrictions below)
 - ♦ Each channel pair uses the same Vth
 - ♦ Resolution: 200 μV
 - ♦ Accuracy: 6 mV
- Sensitivity: 50 mV rms sine, 50 mVp-p pulse

- Hysteresis – prevents false triggering by having separate threshold levels for rising and falling edges
 - ♦ Range: 1 mV to 50 mV
- Minimum slew rate of input signal
 - ♦ Hysteresis > (20 mV or noise level): no minimum
 - ♦ Hysteresis = 1 mV: 200 V/μs (for 1 Vp-p sinewave, minimum frequency is 62 MHz)
- Connector: SMP
- Restrictions on input signal (Vi), trigger threshold voltage (Vth), and termination voltage (Vt). All of these restrictions must be met. For example, if Vt is 1.5 V and Vth is 0.5 V, the third equation states that the input signal can range from -4.5 V to +3.5 V. However, the sixth equation restricts the lower end further to -2.0 V for DC signals and the seventh equation restricts it to -3.5 V for AC signals. For convenience, the instrument software reports the allowed ranges.
 - ♦ $-2 \leq Vt \leq +3$
 - ♦ $-2 \leq Vt - Vth \leq +2$
 - ♦ $-4 \leq Vi + Vt - 2Vth \leq +4$
 - ♦ $-4 \leq Vth + Vt \leq +6$
 - ♦ $-4 \leq Vi + Vt \leq +6$
 - ♦ $-3.5 \leq Vi - Vt \leq +3.5$ (DC)
 - ♦ $-5 \leq Vi - Vt \leq +5$ (AC: 50% duty cycle, >1 kHz)

- Some representative examples:

Application	Vt	Vth	Vi min	Vi max
General	0	0	-3.5	+3.5
CMOS (3V)	1.5	1.5	-2.0	+4.5
CMOS (5V)	2.5	2.5	-1.0	+3.5*
PECL (3.3V)	1.3	2.0	-1.3	+4.7
CML (2.5V)	2.5	2.3	-1.0	+3.5

*Attenuation is required for 5V CMOS (see User Manual)

*With Vt = 0, Vth = 0, maximum input power is +20 dBm

Outputs A, B, and C

- Coupling: DC
- Differential
- Require 50 Ω load to ground (when using as single ended terminate the unused output of a differential pair)
- High level (< 3.5 GHz): 1050 mV ±100 mV
- Low level (< 3.5 GHz): 550 mV ±150 mV
- Amplitude:
 - 500 mV typical (< 3.5 GHz)
 - 200 mV typical (@ 5 GHz)
- Set threshold on receiving instrument to the center of the High and Low levels (800 mV typical)

Definitions

- TriggerErr or StartTriggerErr or StopTriggerErr
 - Error due to noise superimposed on the input signal from both internal and external sources
 - $$TriggerErr = \frac{\sqrt{1mV^2 + E_n^2}}{InputSignalSlewRate} \text{ s rms}$$
 - En = RMS noise of input signal (6 GHz bandwidth)
 - InputSignalSlewRate = Slew rate of input signal (V/s) at the threshold point
- TriggerLevelTimeErr
 - Time error due to threshold uncertainty
 - $$TriggerLevelTimeErr = \frac{< 10mV}{InputSignalSlewRate} \text{ s rms}$$
 - Example: For input signal slew rate = 100V/μs
TriggerLevelTimeErr = 100 ps

Software

- Windows® and Linux driver
 - Provides a powerful set of functions for controlling the instruments
 - Windows® NT/95/98/2000/XP, 32 bit
 - Windows® Vista/7/8/10, 32/64-bit
 - Linux with 2.4/2.6 kernels (e.g. Redhat 3, Redhat 5), 32-bit
 - VBA (for use from excel®, used on some Teradyne testers)
 - Written in plain C++ for easy porting to other environments
- Virtual Front Panel (Windows® based)

- Can run multiple instruments of any model simultaneously
- Compatible with Windows® XP/Vista/Win7 32/64-bit
- Requires Microsoft™ .NET Framework 3.5 (included)
- National Instruments LabVIEW driver

System Requirements

- BI301 and BI302: One 32-bit PXI slot, 3U, legacy or hybrid
- Less than 500 MB disk space

Calibration

- Traceable calibration once a year
 - Requires a voltmeter
- Internal calibration automatically calibrates the instrument against the internal voltage and an internal signal source for skew

Power, Cooling and Physical

- Power supply requirements from PXI bus (typical):
 - BI301: 3.3 V @ 1.8 A 12 V @ 0.9 A
 - BI302: 3.3 V @ 3.6 A 12 V @ 1.8 A
- Total power consumption:
 - BI301: 17 W typical
 - BI302: 34 W typical
- Operating temperature range: 0°C to 45°C
- Weight:
 - BI301: 7 Oz (200 g)
 - BI302: 10.2 Oz (290 g)

Ordering Information

PN	Description
BI301	BI301 5 GHz, 9-Ch MUX, including software
BI302	BI302 5 GHz, 18-Ch MUX, including software
Diff Options	When ordering, specify differential or single ended for each channel pair (four for BI301 and eight for BI302)
7010-0003	Cable, SMP-SMA, 3 ft, RG316
7010-0004	Cable, SMP-SMA, 6 inch, RG316, plus a 50 Ohm SMA terminator

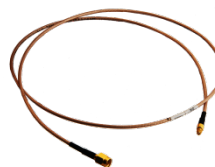

7010-0003 3ft Cable



7010-0004 6 Inch Cables

*Specifications are subject to change without notice
Copyright© 2012-2017 Carmel Instruments, LLC