



## ASF. Single-Shot Autocorrelator for Femtosecond and Picosecond Pulses

- Possible wavelength range from 400 nm to 2200 nm
- 5 fs to 15 ps possible pulse duration measurement
- USB interface with Windows PC software and LabView drivers in a standard package
- CCD 2D detector for precise data acquisition with lowest error
- 1 uJ single-shot sensitivity



The ASF-5 turn-key single-shot autocorrelator

### Product overview

The ASF single-shot autocorrelator is designed for monitoring the pulse duration of ultrafast oscillators and amplifiers, as well as for real-time amplifier systems tuning. The CCD camera registers the transverse section of the non-collinear generation of the second harmonic of the input radiation (the SH is generated in a non-linear crystal). PC USB interface and Windows acquisition software provide for smooth and easy data transition and registration, while additional LabView-compatible drivers offer extended flexibility and on-line control in complex multi-stage experimental setups.

There are four basic models of the ASF family covering a broad possible operating wavelength range.

The ASF-5 system allows measurements of few-cycle pulses with pulse duration as short as 5 fs. The system is based on non-dispersive beam splitting technique providing best accuracy for few-cycle pulse measurement.

The ASF-15 system is a compact unit for routine characterization of low-repetition-rate ultrafast amplifier output as well as seed oscillator output in the range of 15 fs to 200 fs.

The ASF-50 and the ASF-200 units offer extended longer pulse duration measurement limit for ultrashort-pulse amplifier development and tuning. The ASF-200 unit is also used for precise control of pulse duration at the output of commercial laser systems with a tunable compressor unit.

Please feel free to enquire about custom pulse durations and wavelength ranges.

### ASF technical specifications

	ASF-5	ASF-15	ASF-50	ASF-200
<b>Possible wavelength range</b>	400-2200* nm		450-2200* nm	
<b>Input pulse duration range</b>	5-200 fs	15-200 fs	50 fs - 2 ps	200 fs - 10** ps
<b>Required pulse energy</b>	single-shot mode: from 1 uJ at <200 fs; up to 100 uJ at 10 ps; multiple-shot mode: from 1.2 nJ at <100 fs, 80-100 MHz (~100 mW average power)			
<b>Input pulse repetition rate</b>	single-shot...150 MHz; single-shot mode (registration of single pulses): from single-shot to 50 kHz; multiple-shot mode (averaging of 2 or more pulses): >50 kHz			
<b>Input polarization</b>	linear, horizontal (vertical upon request)			
<b>Data interface</b>	USB with Windows PC acquisition and analysis software (included in the standard package)			
<b>Dimensions (LxWxH)</b>	248x54x54 mm	156x120x70 mm	215x120x70 mm	430x240x80 mm
<b>Input beam height range (customized on request)</b>	47/67/87/107 mm (fixed, select one value)	56-110 mm (adjustable)	64-110 mm (adjustable)	64-110 mm (adjustable)

\* - exact wavelength range is quoted based on each customer's requirements;  
\*\* - from 500 fs to 15 ps on request; combined ranges from 100 fs may also be possible upon request for some cases.

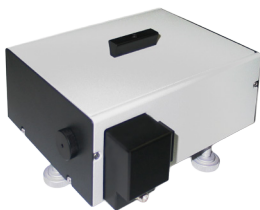

The ASF-15 single-shot autocorrelator



The ASF-200 single-shot autocorrelator

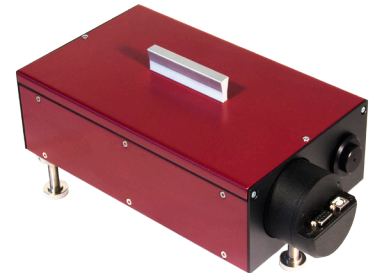

The ASF-50 single-shot autocorrelator



**AVESTA**  
LASERS AND OPTICAL SYSTEMS



Avesta Ltd., 11 Fizicheskaya Street  
Troitsk, 108840, Moscow, Russia  
Tel.: +7 (495) 967-94-73  
Tel.: +7 (495) 851-00-78

fs@avesta.ru  
www.avesta.ru

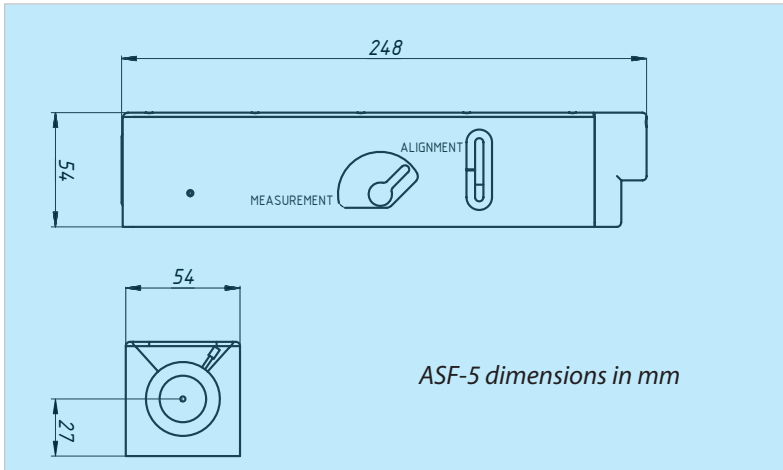

ASF-5 dimensions in mm

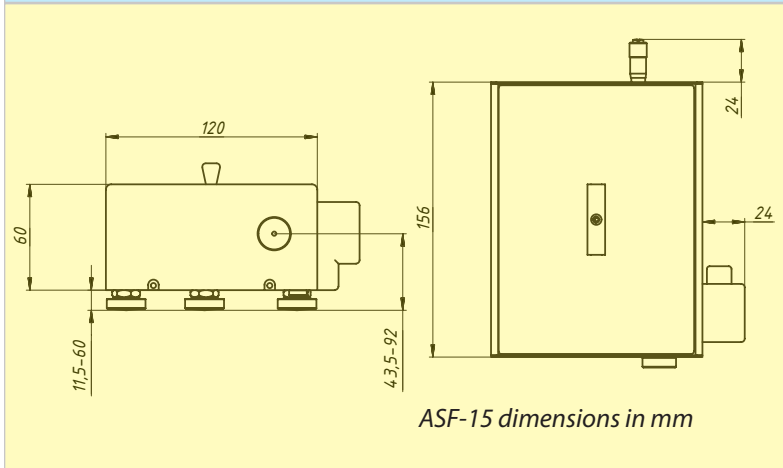

ASF-15 dimensions in mm

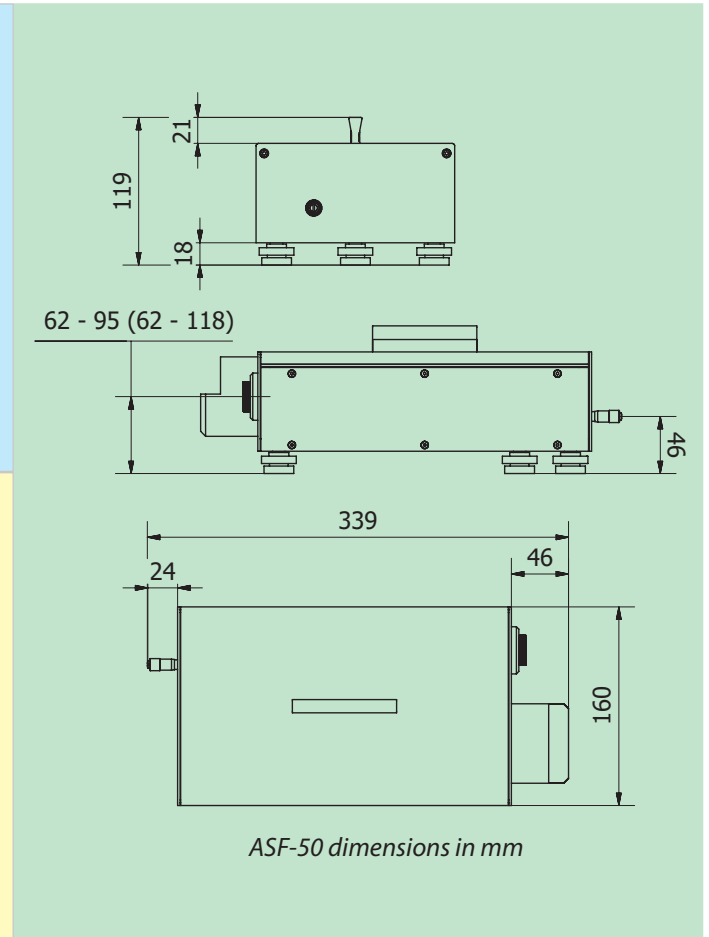

ASF-50 dimensions in mm

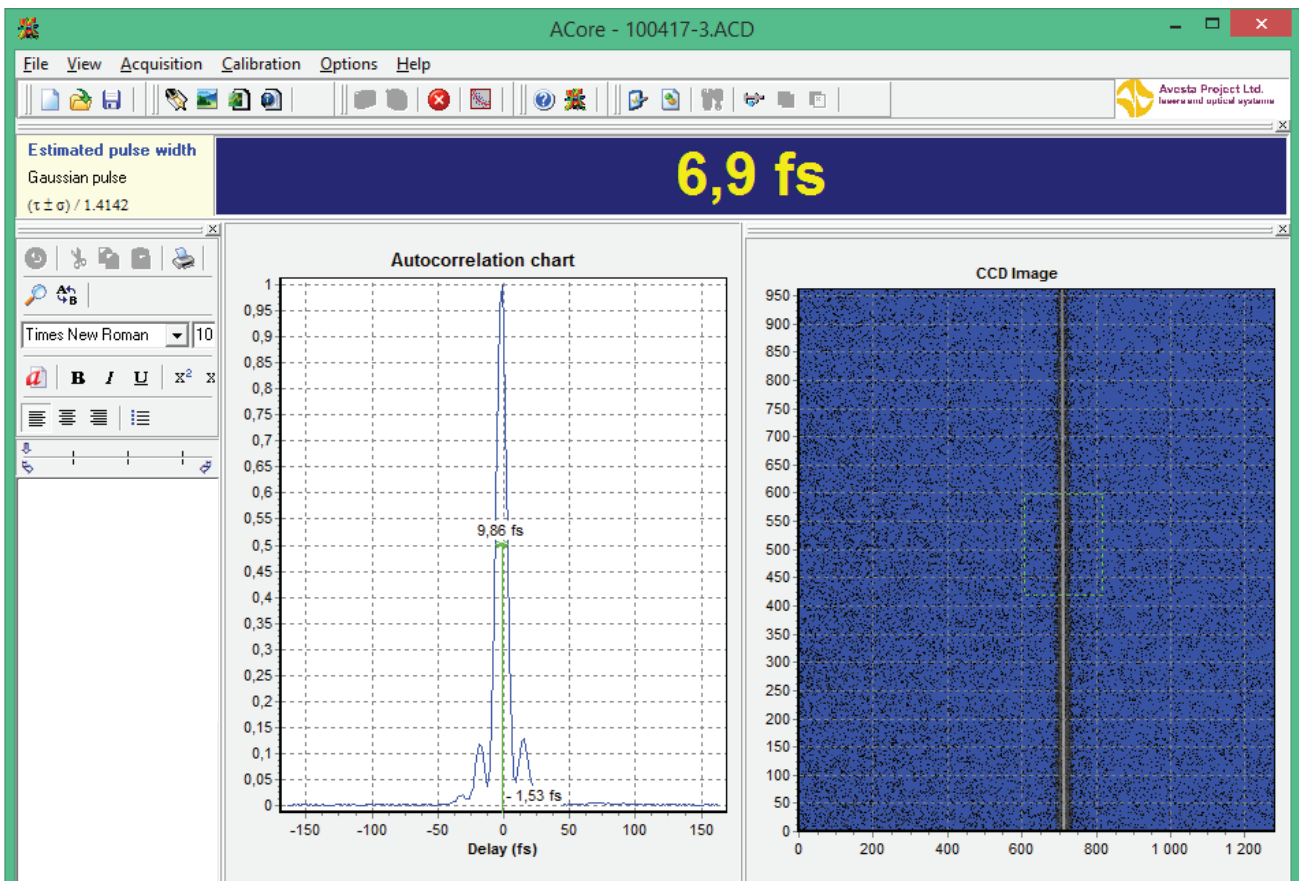

ASF Windows PC software with sample measurement result by the ASF-5 unit (Compulse-800 hollow-fiber compressor output)

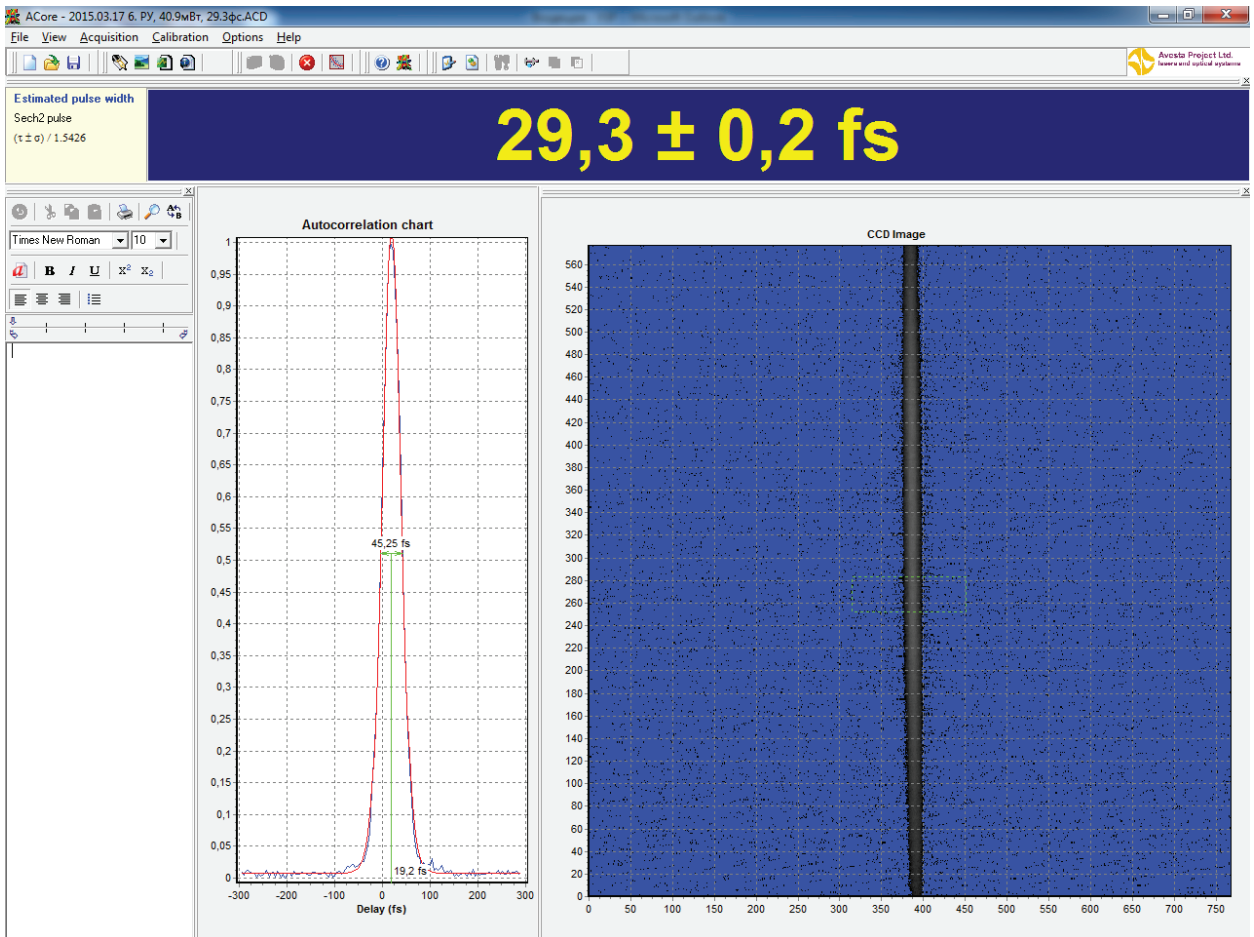

ASF Windows PC software with sample measurement result by the ASF-15 unit (REUS-3m1k Ti:S femtosecond amplifier output)

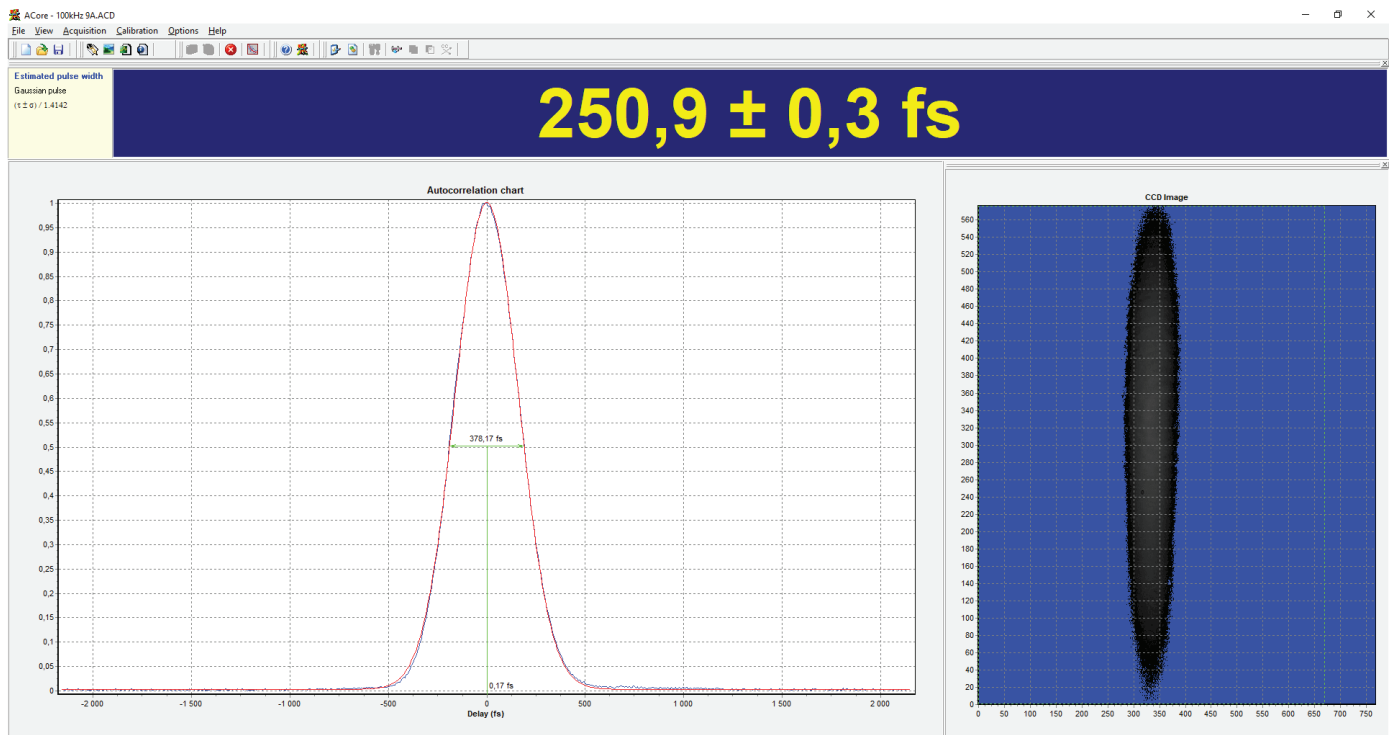

ASF Windows PC software with sample measurement result by the ASF-50 unit (TETA Yb femtosecond amplifier output, near TL)

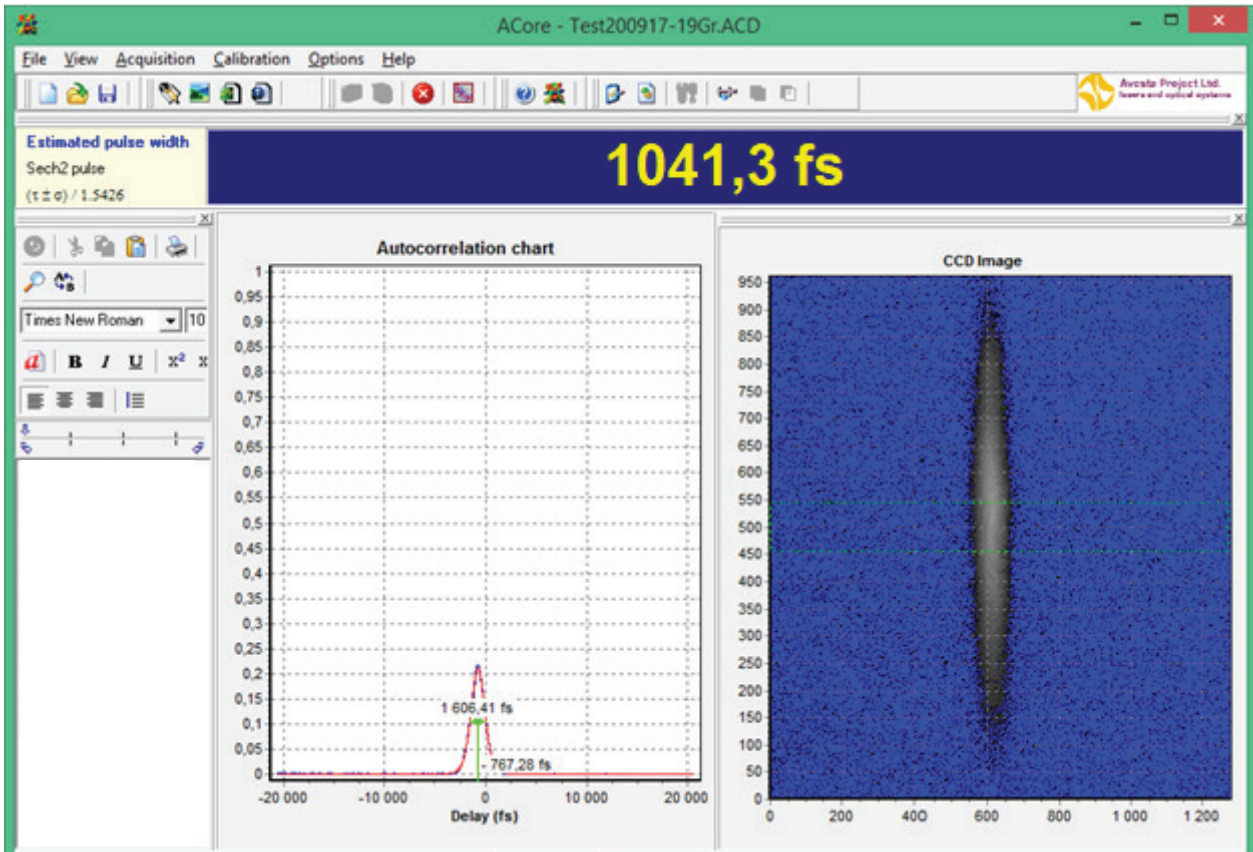

ASF Windows PC software with sample measurement result by the ASF-200 unit  
(TETA-6/200 Yb-doped laser system with tunable pulse duration output, positive chirp)

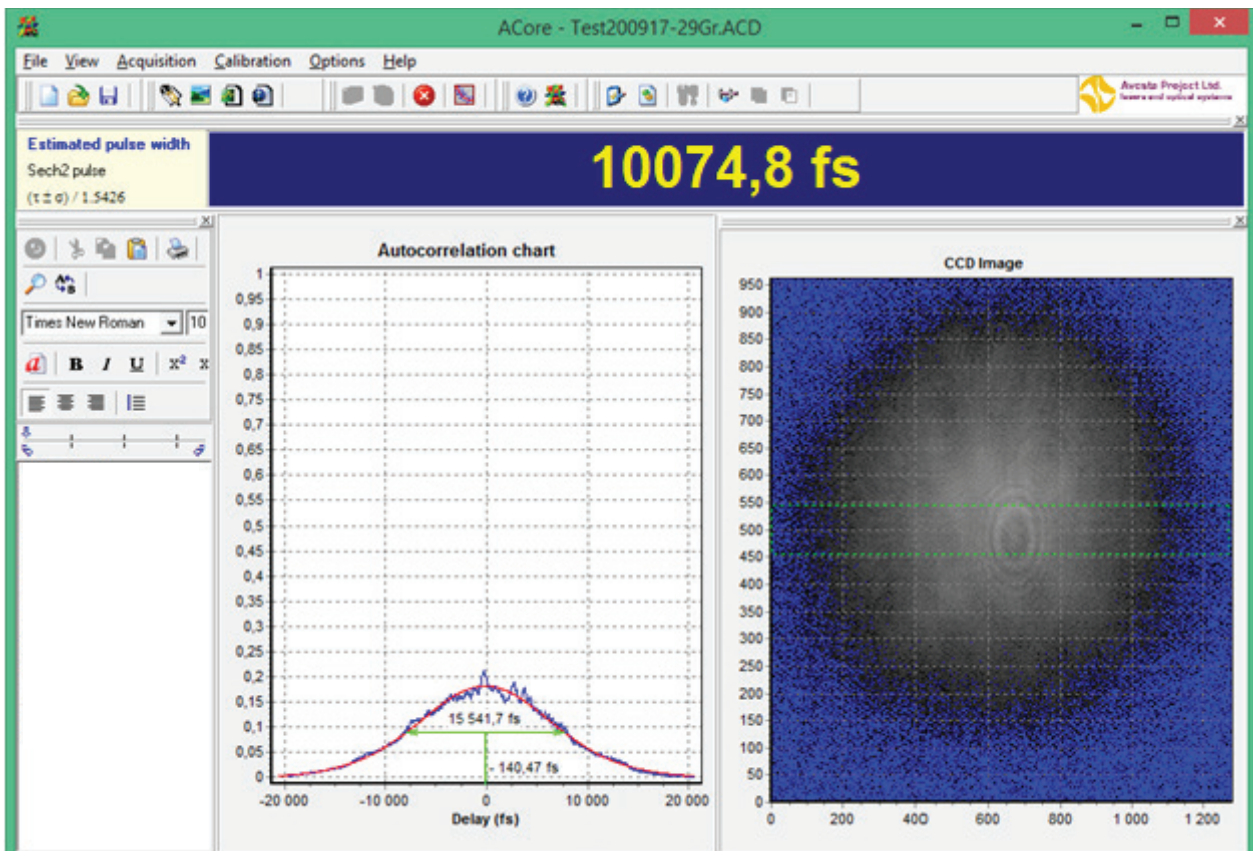

ASF Windows PC software with sample measurement result by the ASF-200 unit  
(TETA-6/200 Yb-doped laser system with tunable pulse duration output, positive chirp)