

HiCATT

High-speed intensified Camera Attachment



The HiCATT is an intensified camera attachment specifically designed for use in combination with high-speed cameras. It can be used to amplify low light level images to a level up to 10000 times, thereby boosting the sensitivity of the attached high-speed camera and enabling high-speed, low light-level imaging. The HiCATT attaches to all major brand high-speed cameras by using a high-quality lens coupling.

The hybrid Image Intensifier of the HiCATT consists of 2 stages and can be delivered with a diameter of either 25 mm or 18 mm. The first stage is a Gen II or Gen III proximity-focused MCP intensifier and offers a very high, adjustable gain. The second stage is a proximity-focused Gen1 booster, producing the extra high output brightness required for imaging at high frame rates. In its gating mode the first stage functions as a fast electro-optical shutter with effective exposure times down to the nanosecond regime. The intensifier can be operated at repetition rates of up to 2.5 MHz in burst.

A series of different intensifier control units provide functionality ranging from analog gain control to full digital control including an internal trigger generator and programmable gate trains.

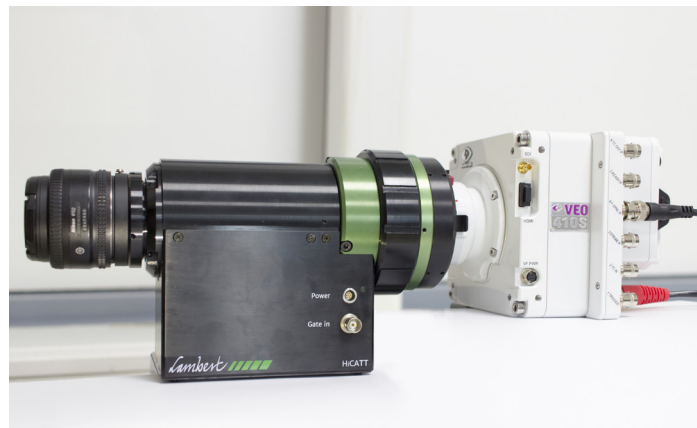

With a wide range of Gen II and Gen III image intensifiers the HiCATT offers high sensitivity down to single photon level and the optimal spectral bandwidth for your application. Different models covering a range in spectral sensitivity, phosphor, spatial resolution, gain, linearity, minimum gate width and gating frequency are available.

Standard, the first stage image intensifier of the HiCATT is equipped with a single MCP. Dual MCP image intensifiers are available on request.

KEY FEATURES

Easy coupling

Flexible and efficient lens coupling to all major brand high-speed cameras (up to 300 000 fps)

High-resolution image intensifiers

Gen II and Gen III image intensifiers offering the world's highest resolution and sensitivity in the UV, visible or near infrared

Small gate widths

Gate width down to less than 3 ns (FWHM) with minimal jitter

High gate repetition rates

Up to 300 kHz/2.5 MHz burst

Compact design

For an easy fit to your imaging or spectroscopy setup

Overexposure protection

User-definable anode current limitation

APPLICATIONS

Particle Image Velocimetry (PIV)

Laser Induced Fluorescence (LIF)

Combustion

Single photon imaging

Bio- and Chemiluminescence Imaging

Plasma physics

Astronomy

Time-resolved imaging and spectroscopy

Image Intensifier Layout

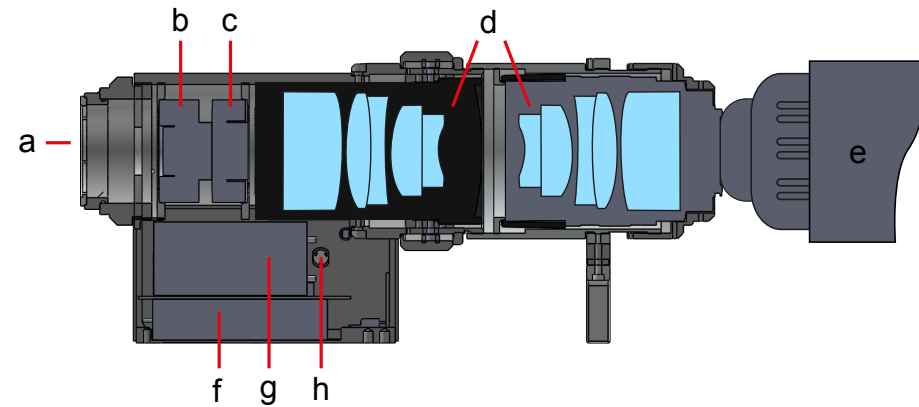

- a) light
- b) image intensifier
- c) booster
- d) relay lens
- e) camera
- f) gate unit
- g) MCP power supply
- h) gate input (TTL)

When the HiCATT is mounted to a lens or microscope, the incoming light (a) is focused onto the entrance window of the image intensifier (b). The image intensifier converts the optical image to electrons at the photocathode, amplifies this electron image at the micro-channel plate (MCP), and re-converts the electrons into photons at the anode screen. The second image intensifier (booster, c) further amplifies the signal. At the output of the hybrid intensifier a relay objective (d) is mounted with a magnification that matches the intensifier to the high-speed camera sensor (e).

For time-resolved imaging a gate unit (f) is used together with the image intensifier to yield an electro-optical shutter. The gate unit either generates a high voltage pulse signal or follows an external TTL pulse. The pulse width is variable and follows a TTL input pulse over the range from less than 3 ns to DC at a repetition rate up to 300 kHz.

Spectral response and phosphor decay time

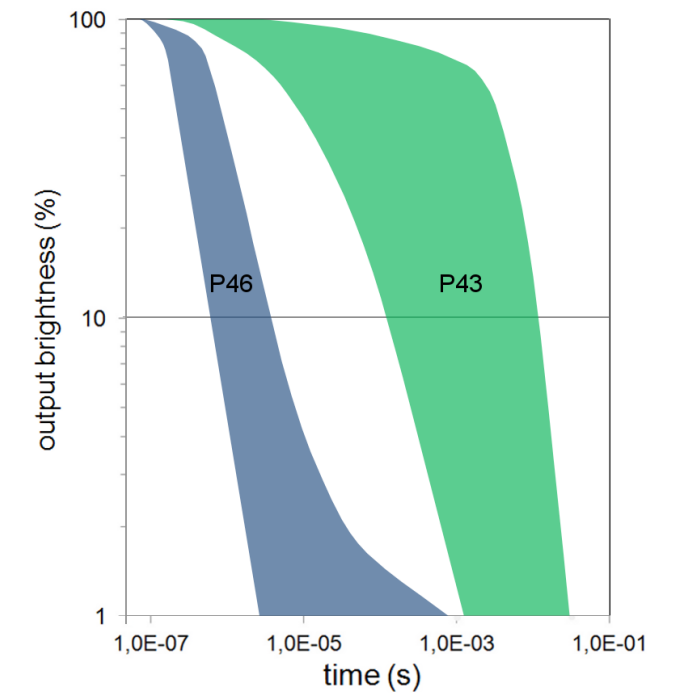
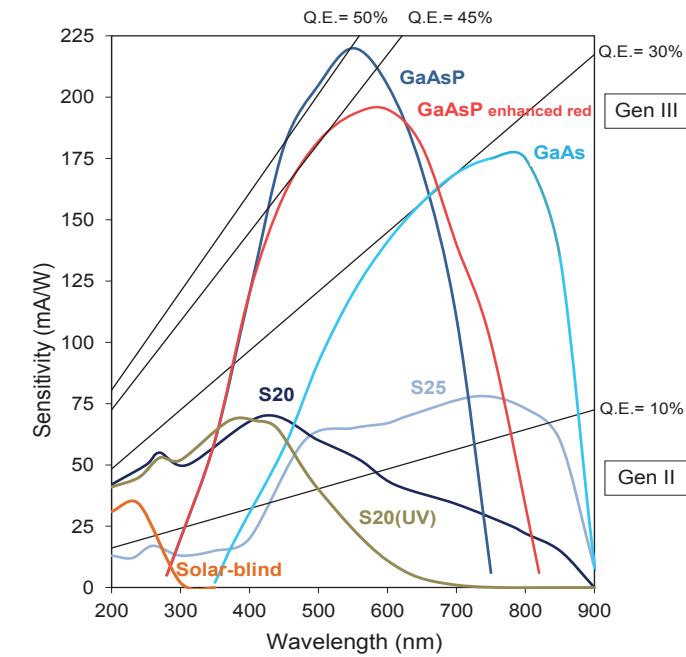

Phosphor	Efficiency	Decay time to 10%	Decay time to 1%
P43 (optional)	20 photons/e-/kV	1.5 ms	3 ms
P46 (standard)	6 photons/e-/kV	500 ns	2000 ns

P20 and P24 available on request

IMAGE INTENSIFIER SPECIFICATION

Min. gate width (FWHM)	HiCATT G 40n: 40ns HiCATT G 2n: < 3 ns with Gen II, 5 ns with Gen III	
Max. repetition frequency	HiCATT G 40n: 100 kHz HiCATT G 2n: 300 kHz, 2.5 MHz in burst mode	
First stage image intensifier	Proximity-focused Gen II or Gen III (filmless)	
Second stage image intensifier	Proximity-focused Gen I	
Input window	S20: Quartz. S25, GaAs, GaAsP: Borosilicate glass	
Sensitivity and spectral range	See graph on page 3 (top-left)	
Photon gain (max)	S20: 40000, S25: 30000, GaAs: 30000, GaAsP: 50000	
Equivalent Background Input	S20: 0.006, S25: 0.008, GaAs: 0.024, GaAsP: 0.006 photo e ⁻ /px/s	
Phosphor	P46 (P20, P24, P43 on request)	
Input lens mount	F-mount (C-mount on request)	
Output lens mount	F-mount (C-mount on request)	
Available relay lenses	1:1, 2:1, 3:1	
Typical resolution on output (lp/mm)	1:1 relay lens 2:1 relay lens 3:1 relay lens	S20: 33, S25: 31, GaAs: 28, GaAsP: 26 S20: 66, S25: 62, GaAs: 56, GaAsP: 52 S20: 99, S25: 93, GaAs: 84, GaAsP: 78
	HiCATT 18	HiCATT 25
Effective area	Gen II: ø 17.5 mm, Gen III: 13.5x10 mm	Gen II: ø 24.5 mm, Gen III: 16x16 mm
Input diameter	18 mm	25 mm
Input window thickness	5.5 mm	6.0 mm

Intensifier working principle

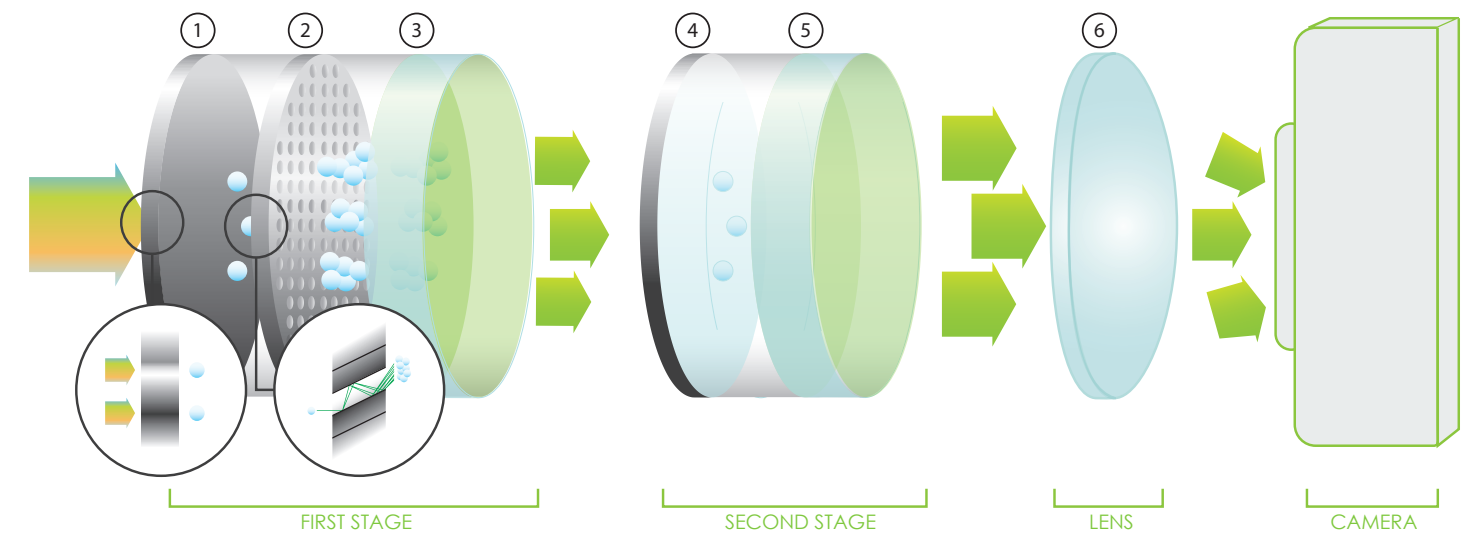

On the photocathode(1) photons get converted into electrons. These are accelerated in an electric field towards the Multi Channel Plate (MCP, 2) and hit the channel walls. Depending on the voltage across the channel, multiple electrons are generated by secondary emission. This cloud of electrons gets accelerated towards the anode screen (3), where the electrons are converted back into photons by the phosphor layer.

These photons are guided by a fiberoptic faceplate (3) to the entrance of the second stage (booster).

Again photons are converted to electrons by the photocathode (4) and accelerated to the anode screen (5) where the image appears. The relay lens (6) transfers the image from the back of the intensifier onto the mounted camera.

Gating

The HiCATT can be used as an ultra-fast electro-optical shutter by gating the image intensifier. This eliminates motion blur and reduces the effective exposure time, thereby significantly widening the camera's dynamic range. To prevent loss of intrascene dynamic range when using a shorter gate the user can set a higher MCP gain. The pulse width and frequency are user defined: any pulse width from DC down to a few nanoseconds can be applied.

The table below summarizes the range of different intensifier control units available for the HiCATT.

- The gain control models act as a power supply for the image intensifier, gate pulse trains are supplied externally.
- The gate control model has its own pulse generator, giving the user direct control of the gate width and gate delay.
- The gate generator models have an enhanced version of the pulse generator with lower jitter. These models allow the image intensifier to be synchronised to the exposure time of the camera by supplying a trigger signal.
- All models allow the gate frequency to be set by an external TTL signal.

Microsoft Windows control software is provided with all control unit models, except the manual model. The software provides full user control of the pulse width and delay, gating mode, and intensifier gain. The control unit is connected to the computer via USB (RS-232 is optional). For integration in third party software a full command set is available.

The enhanced pulse generator of the gate generator models has 4 independent programmable pulse outputs (one of which is used for gating) that provide precise timed TTL pulses with pulse widths down to less than 3 ns (FWHM).

The intensifier gate generator is optionally available with programmable gate patterns. A frame storage facility allows storing many different delay/width-settings and the creation of scenarios of freely definable gate sequences.



Example 1: alternating gate width

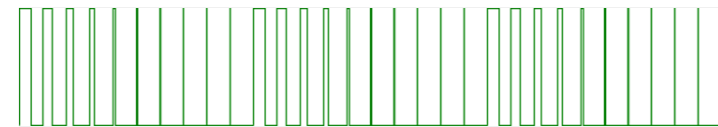

Example 2: repeated linear reducing gate width



Example 3: complex gate pattern

CONTROL UNITS AND GATING PROPERTIES

Control Unit Model	No control unit	Intensifier gain control	Intensifier gate control	Intensifier gate generator
Gain control	Manual	✓	✓	✓
Gate control	External TTL	External TTL	✓	✓
Anode current limiter	x	✓	✓	✓
Internal trigger generator	x	x	✓	✓
Programmable gate pattern	x	x	3 presets	Optional (IC-PG-USB)
Shutter control	x	Optional	Optional	✓
Additional TTL outputs	x	x	2	3
Gating properties				
Width range			10 ns – 10 s	< 3 ns – 10 s
Resulting min pulse width (increments)			10 ns (10 ns)	< 3 ns (10 ps)
Pulse repetition rate			< 10 MHz	< 16 MHz
Delay jitter (width)			10 ns (< 250 ps RMS)	< 35 ps (< 35 ps)
Insertion delay			20 ns	20 ns
Trigger input			✓	Programmable trigger level, divider and bursts (m out of n triggers)

Configurations

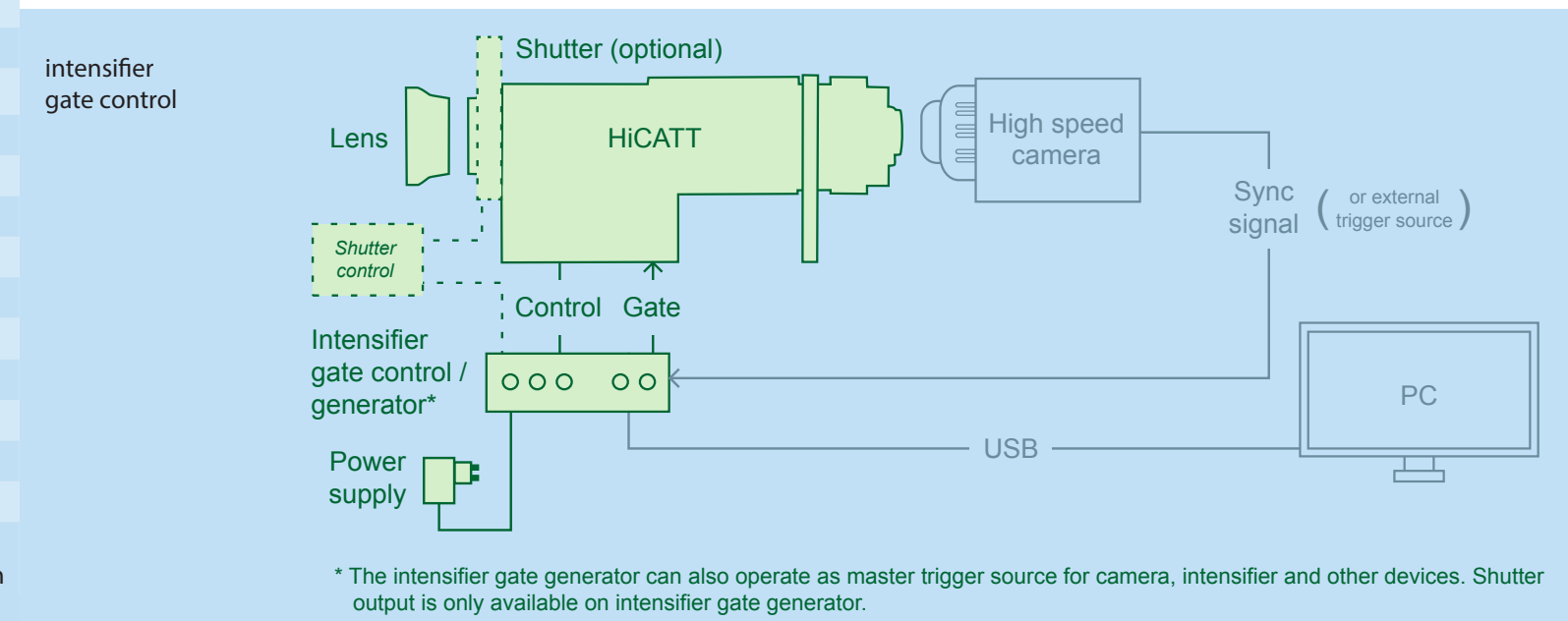
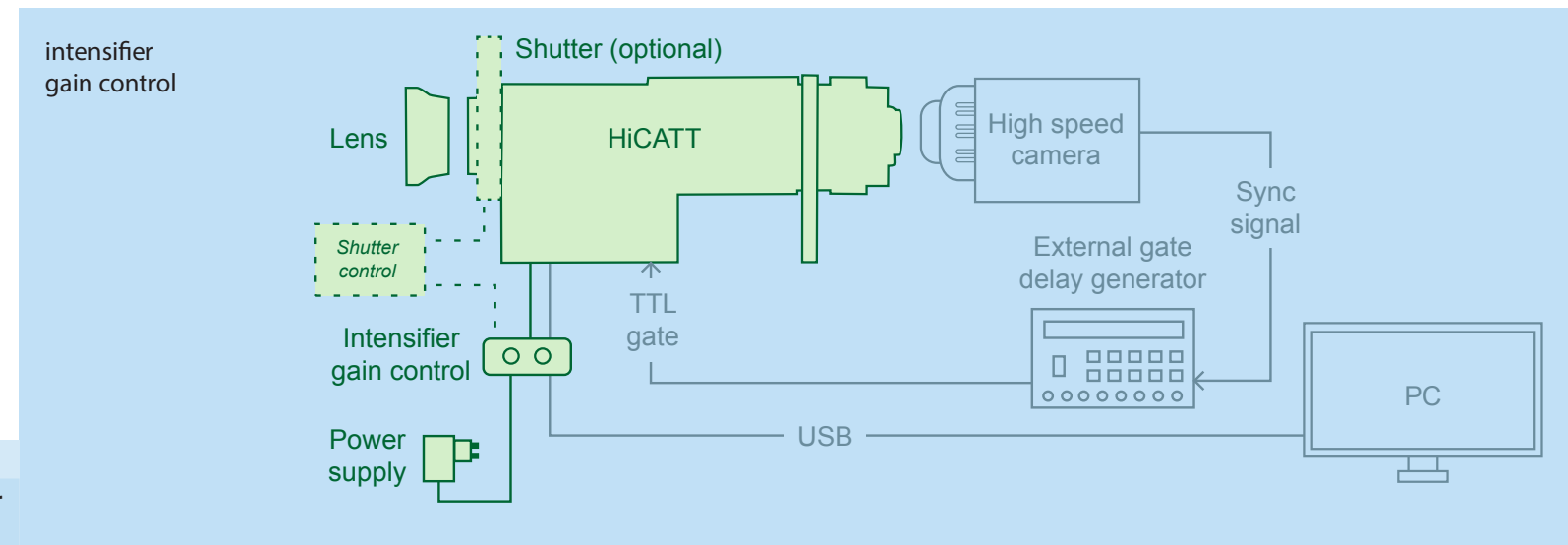
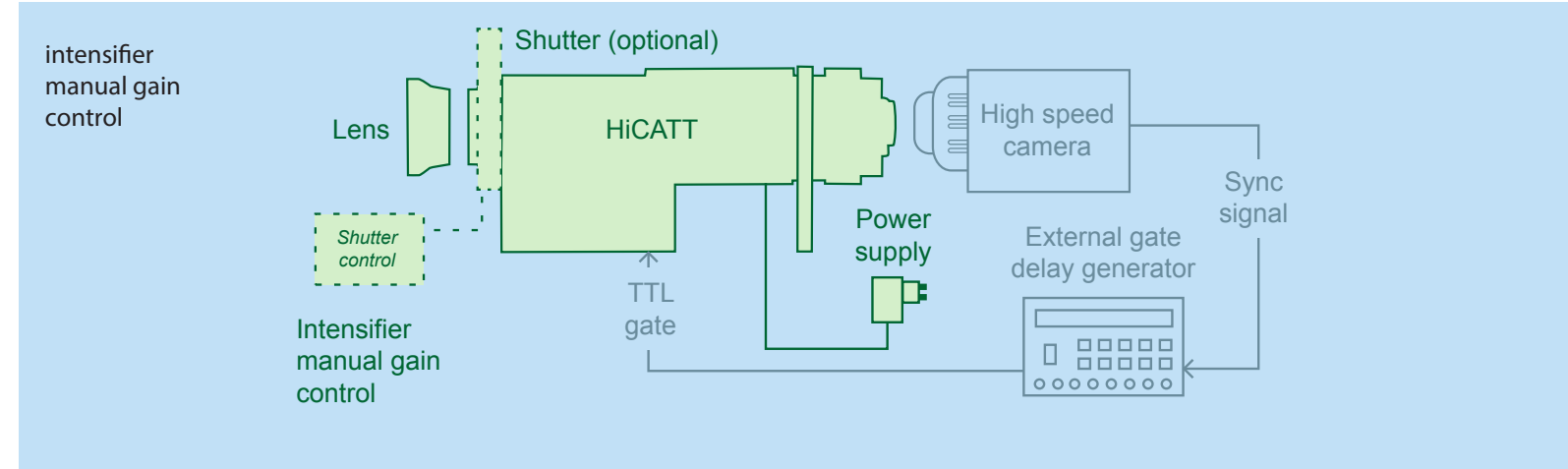

Dimensions and operating conditions

HiCATT 25 with 1:1 relay lens	
Supply voltage	15 Vdc
Power	10 W
Operating temperature	5 °C – 40 °C
Operating humidity (non-condensing)	20% – 80%
Weight	3.2 kg

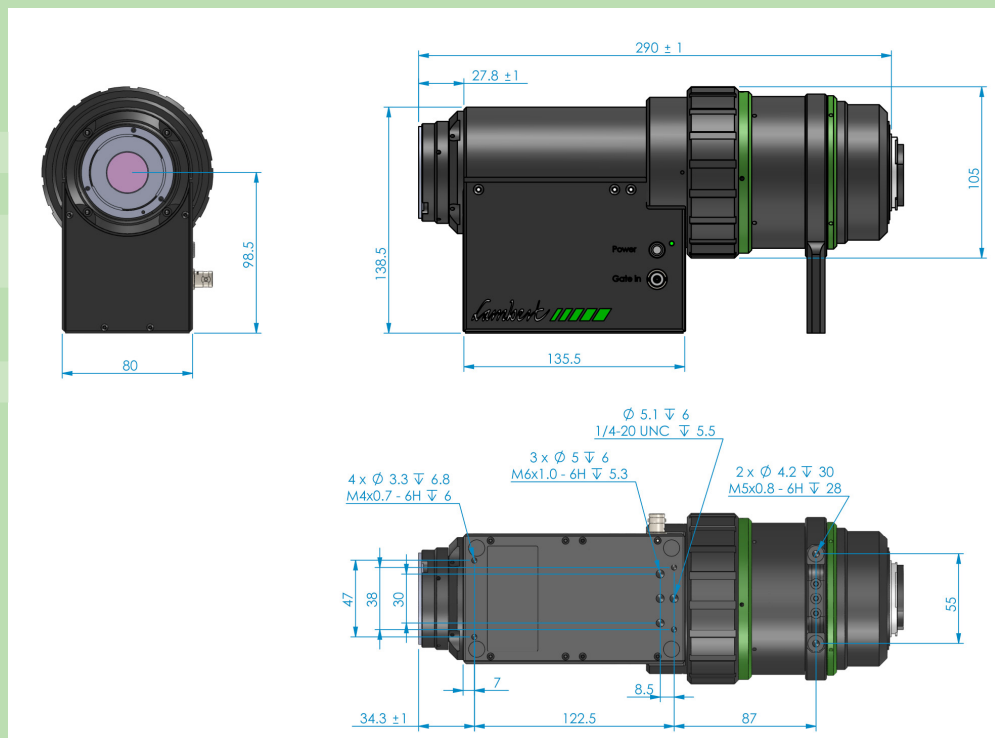

HiCATT 25 with 2:1 relay lens	
Supply voltage	15 Vdc
Power	10 W
Operating temperature	5 °C – 40 °C
Operating humidity (non-condensing)	20% – 80%
Weight	2.5 kg

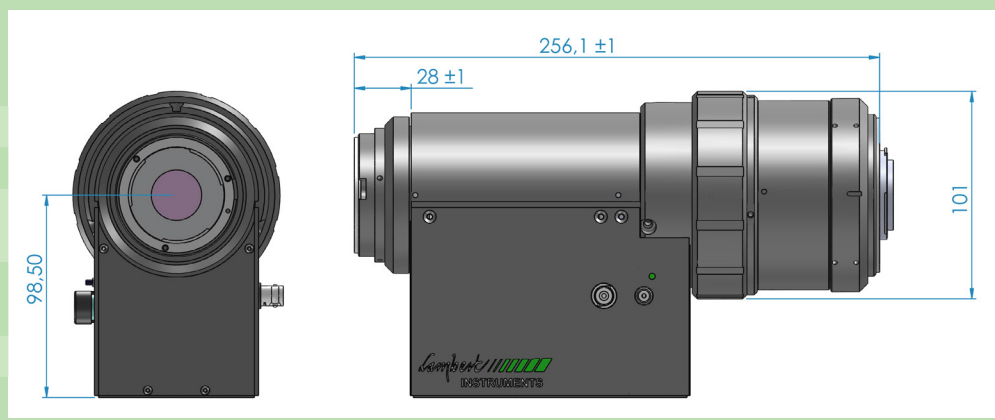

HiCATT 18 with 1:1 relay lens	
Supply voltage	15 Vdc
Power	10 W
Operating temperature	5 °C – 40 °C
Operating humidity (non-condensing)	20% – 80%
Weight	2.2 kg

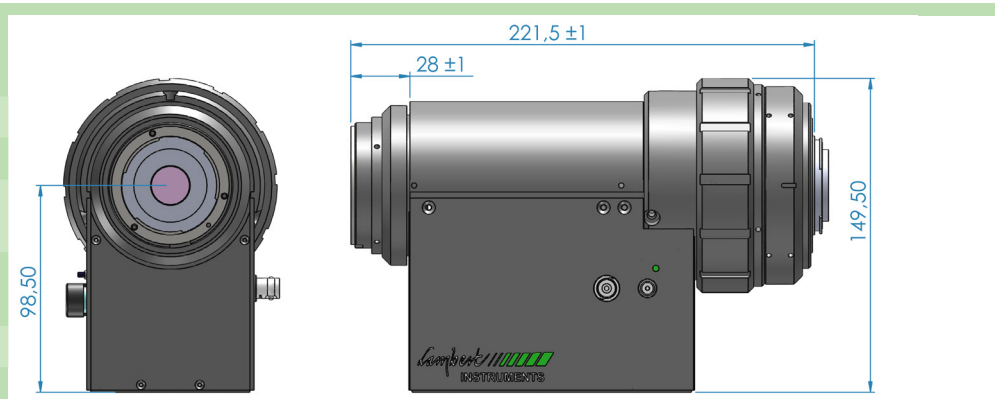

	Gain control IC-DG-USB	Gate control IC-GC-USB	Gate generator / P IC-GG-USB / IC-PG-USB
Dimensions W x D x H	78 x 120 x 27	157 x 198 x 72	291 x 198 x 75 mm
Weight	0.5 kg	1 kg	1.4 kg
Working Voltage	90V AC to 264V AC 47-63 Hz	85V AC to 264V AC 47-63 Hz	85V AC to 264V AC 47-63 Hz
Power	< 18 W	< 25 W	< 25 W
Fused		800mA T	800mA T
Entrée	IEC 320	IEC 320	IEC 320
Safety	IEC 60939:1988 EN133200:1994	IEC 60939:1988 EN133200:1994	IEC 60939:1988 EN133200:1994
IP Rating	30	30	30

Mechanical shutter

The HiCATT can be supplied with an optional mechanical shutter for preventing damage to the image intensifier by high intensity stray light or direct laser light. It is further recommended to close the shutter between measurements to increase the lifespan of the image intensifier.

The shutter replaces the original F-mount adapter of the HiCATT. The back focal distance of the F-mount input is unchanged so any F-mount objective can be used. The shutter comes with a power supply and a remote control. A timer can be used to automatically close the shutter after a predetermined time. The remote control has an ergonomic design and a large LCD screen. The shutter can also be controlled by the software of the HiCATT or by an external TTL signal.

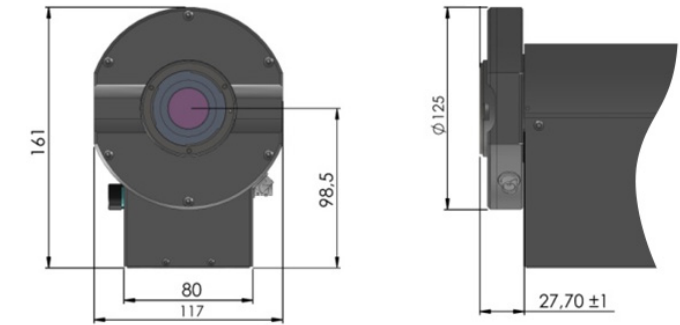

SHUTTER SPECIFICATION

Shutter	UNIBLITZ VS35
Repetition Rate	DC to 5 Hz (20 Hz burst of maximal 4 s, with 1 min between bursts)
Transfer time on opening/closing	13 ms
Minimal open time	20 ms
Lens mount	F-mount
Shutter control via	- Hand held remote control with push button and timer - External TTL signal
Delay-timer specification	1 s to 99 hrs in 1 sec increments
TTL input	0-5 V, minimal pulse width of 20 ms

Applications

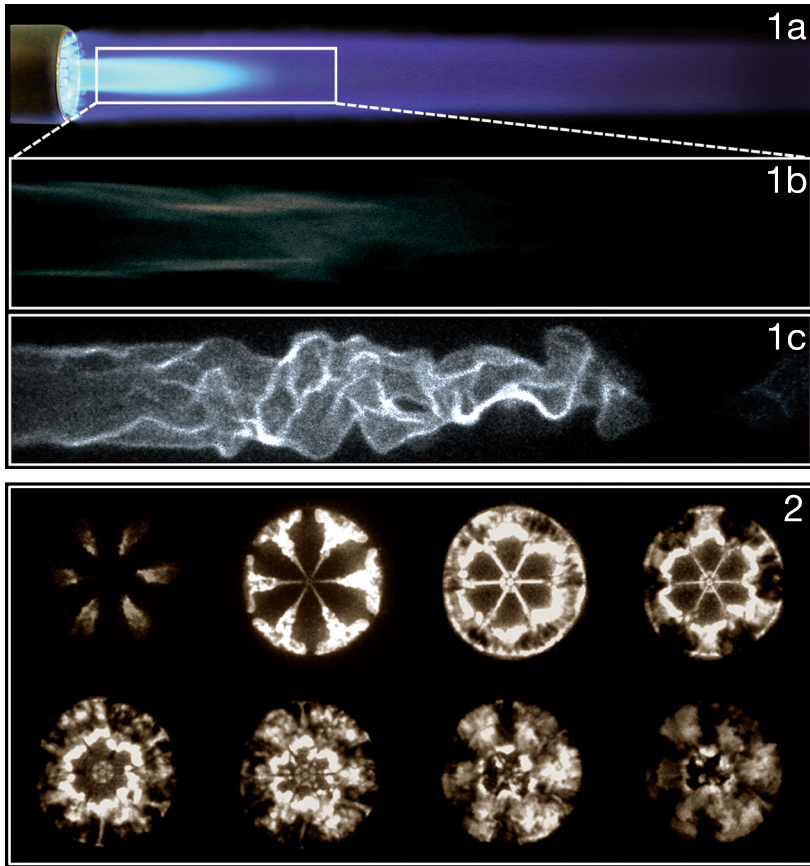

1a. Recording a blue gas flame from a Bunsen burner at high frame rates poses a challenge. The light intensity of the flame is low and to be able to see any details, especially in close-ups, very short exposure times are required.

1b. Recording made with a standard high-speed camera at 1000 fps and 1 ms exposure time. On the one hand, a long exposure time is needed to increase the sensitivity of the camera. On the other hand, a short exposure time is necessary to prevent motion blur.

1c. Recording made with the HiCATT in front of the high-speed camera at 2000 fps and 15 μ s exposure time (using gating). The HiCATT makes it possible to capture flames at frame rates up to 300.000 fps. By using gating fast electro-optical shutter function of the image intensifier, the exposure time can be limited to a value at which motion blur is no longer an issue.

2. Recording sequence made with the HiCATT in combination with a high-speed camera. The recording shows a combustion cycle of a fuel injection engine at 22.000 fps.