

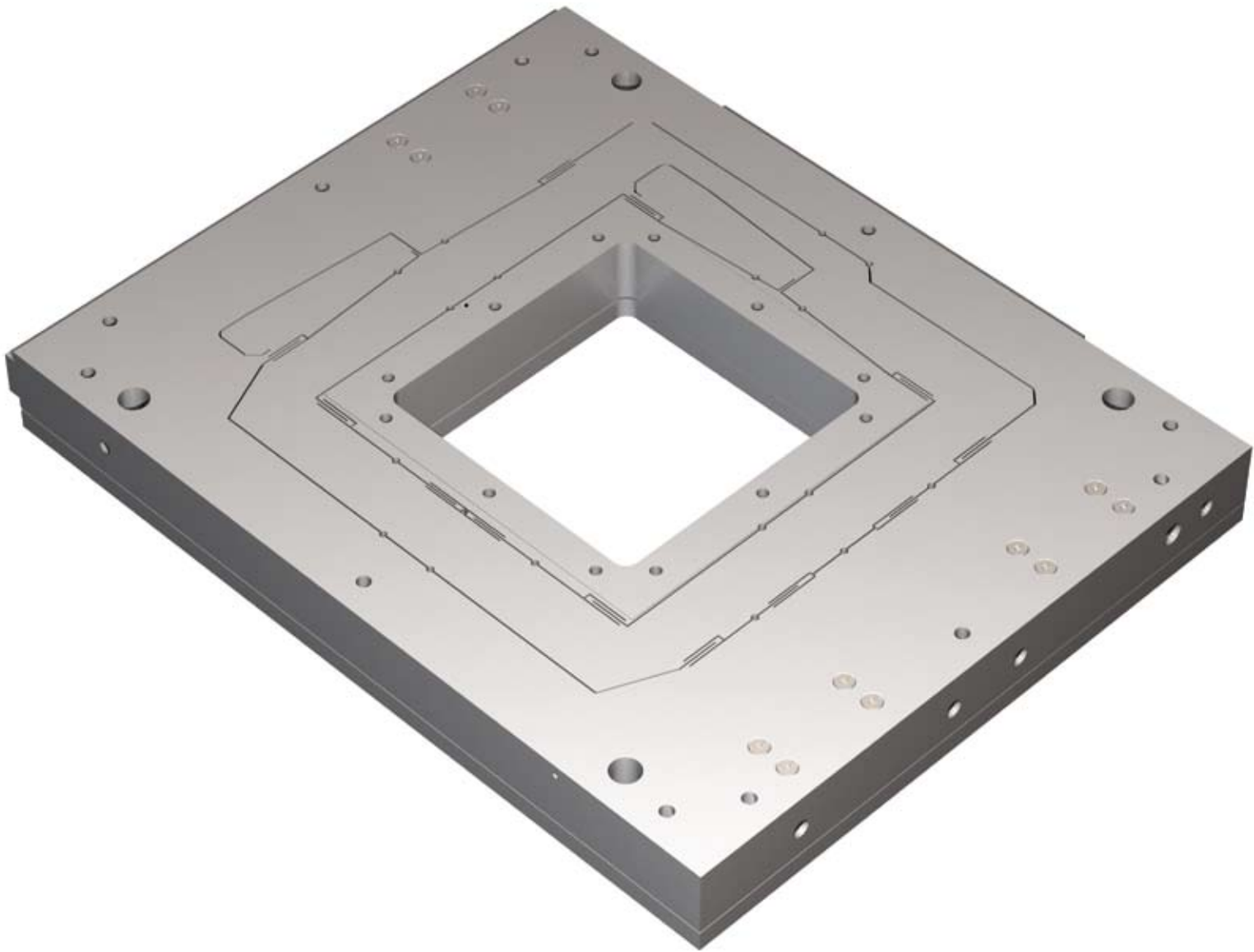

PIEZOCONCEPT

Your piezostage Creator

Picometric Noise Floor Nanopositioners



www.auniontech.com

CONTACT

How can we help you ?

We can support you :

- by the development of complete positioning solutions
- in choosing the right products for your requirement
- in helping you to integrate the stage into your set-up.

You can contact us by phone at +33(0)478742456

Or by email at : info@auniontech.com

Web : www.auniontech.com



PIEZOCONCEPT

Your piezostage creator

INTRODUCTION

PIEZOCONCEPT is the leading provider of nanopositioners dedicated to applications such as Super Resolution Microscopy, Optical Trapping and Atomic Force Microscopy. Our customers include many leading scientists engaged in leading edge research at world class universities and institutes. For many decades, researchers bought stages equipped with capacitive sensors. But our users wanted better stability and linearity and new powerful microscopy techniques demanded a major rethink. Something more stable was required. We decided to take a long hard look at these systems and see if there was a better, more elegant, solution to providing accurate and stable positioning. We developed a range of ultra-stable nanopositioners able to meet a wide range of microscopy applications with significant advantages over the currently available products.

As one of our biggest advantages, the sensor we use outperforms high-end capacitive sensor because of their exceptionally high signal, leading to picometric stability. Also, because of the very low-noise electronics and the flexure design stage we offer, we can ensure subnanometric (or sub-nanoradian) noise floor.

Dr. Samuel CHOBLET
CEO of PIEZOCONCEPT



CONTENTS

Single axis translation stage

HS1	pages 06-07
HS1 Aperture	pages 08-09

Single axis Z piezostage

FOC	pages 10-11
Z-insert	pages 12-13

Two axis XY piezostage

BIO2	pages 14-15
LT2	pages 16-17
LFHS2	pages 18-19
LTHS2	pages 20-21

Two axis Tip-Tilt piezostage

TT2	pages 22-23
-----------	-------------

Three axis XYZ piezostage

BIO3	pages 24-25
LT3	pages 26-27
LFHS3	pages 28-29
CUBE3	pages 30-31

Microscopy Products

Manual microstage	pages 32-33
Hybrid system	pages 34-35
Sample holders	pages 36-38

Controller	page 39
------------------	---------

Glossary	pages 40-41
----------------	-------------

Sales conditions	page 43
------------------------	---------

APPLICATIONS

Active optics

HS1	pages 06-07
FOC	pages 10-11
TT2	pages 22-23
CUBE3	pages 30-31

Optical microscopy (Super Resolution, Optical tweezer...)

Z-insert	pages 12-13
BIO2	pages 14-15
LT2	pages 16-17
LFHS2	pages 18-19
LTHS2	pages 20-21
TT2	pages 22-23
BIO3	pages 24-25
LT3	pages 26-27
LFHS3	pages 28-29
Hybrid system	pages 34-35

NSOM / Atomic force microscopy

HS1	pages 06-07
BIO2	pages 14-15
LT2	pages 16-17
BIO3	pages 24-25
LT3	pages 26-27
Hybrid system	pages 34-35

High speed applications

HS1	pages 06-07
LFHS2	pages 18-19
LTHS2	pages 20-21
TT2	pages 22-23
LFHS3	pages 28-29

HS1 NANOPositionER

The HS1 is a compact nanopositioner which can be combined to form 2 or even 3-axis nanopositioning systems. It is offered with 30, 50 or 70 μ m of range of motion and it can also be proposed with an aperture (see page 08).

This nanopositioner is part of our high-speed product line (High power controller available).

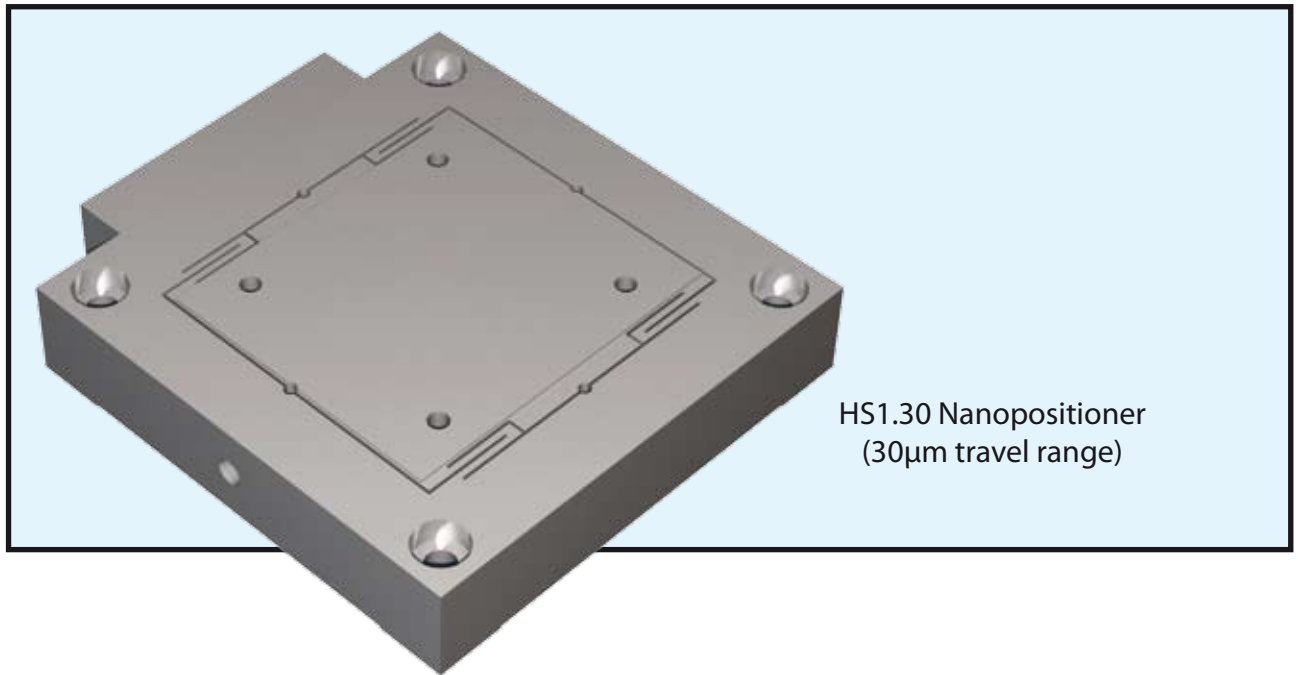

Features

- High speed, direct drive
- Stackable for XY or XYZ motion
- 30, 50 or 70 μ m motion
- Closed loop control
- Silicon sensor technology
- Less than 10pm noise floor

Applications

- Interferometry
- Nanolithography
- 3D polymerisation
- High speed focusing
- Adaptative optics

Specifications

	HS1.30	HS1.50	HS1.70
Range of motion (μm)	30	50	70
Resolution (nm)	0,03	0,05	0,07
Typical noise floor (nm)	0,003	0,005	0,007
Full range repeatability (nm)	0,06	0,1	0,14
Linearization (typical)	0,02%	0,02%	0,02%
Resonant frequency (Hz)	4000	4000	4000
Stiffness ($\text{N}/\mu\text{m}$)	3	3	3
Maximum load (kg) - horizontal use	1	1	1
Maximum load (kg) - vertical use	0,5	0,5	0,5
Sensor	Silicon HR sensor	Silicon HR sensor	Silicon HR sensor
Size W x L x H (mm)	62,5 x 69,50 x 12,6	62,5 x 89,50 x 12,6	62,5 x 111,50 x 12,6
Material	Al	Al	Al
Cable length (m)	2	2	2
Recommended Controller	Standard or High Speed	Standard or High Speed	Standard or High Speed

Drawing

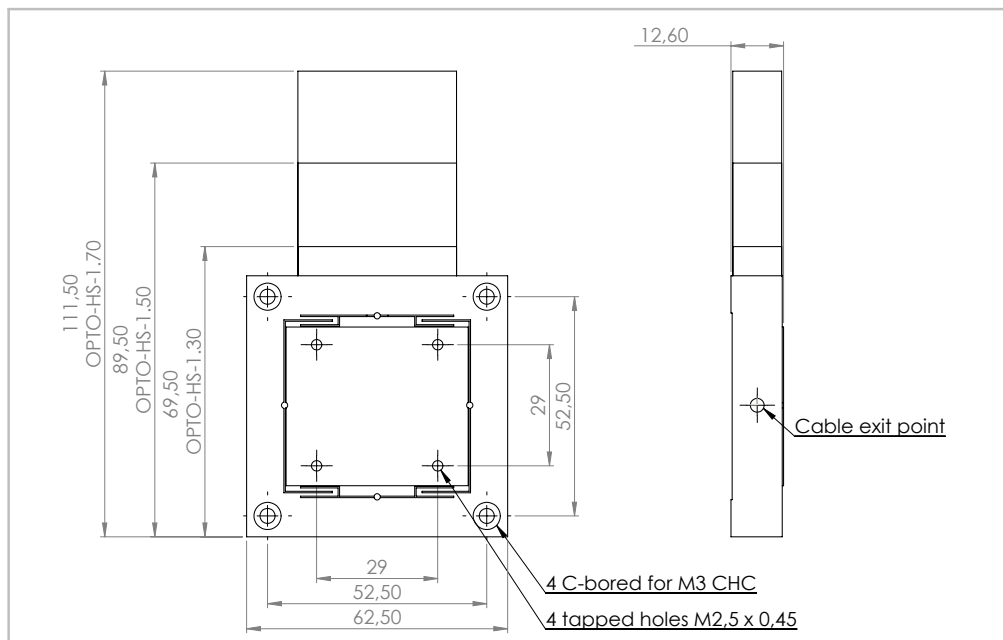

HS1-APERTURE NANOPositionER

The HS1-APERTURE is a compact nanopositioner which can be combined to form 2 or even 3-axis nanopositioning systems. It is offered with 30, 50 or 70 μ m of range of motion and has a central aperture of 33mm, making it ideal for optical microscopy applications.

This nanopositioner is part of our high-speed product line (High power controller available).

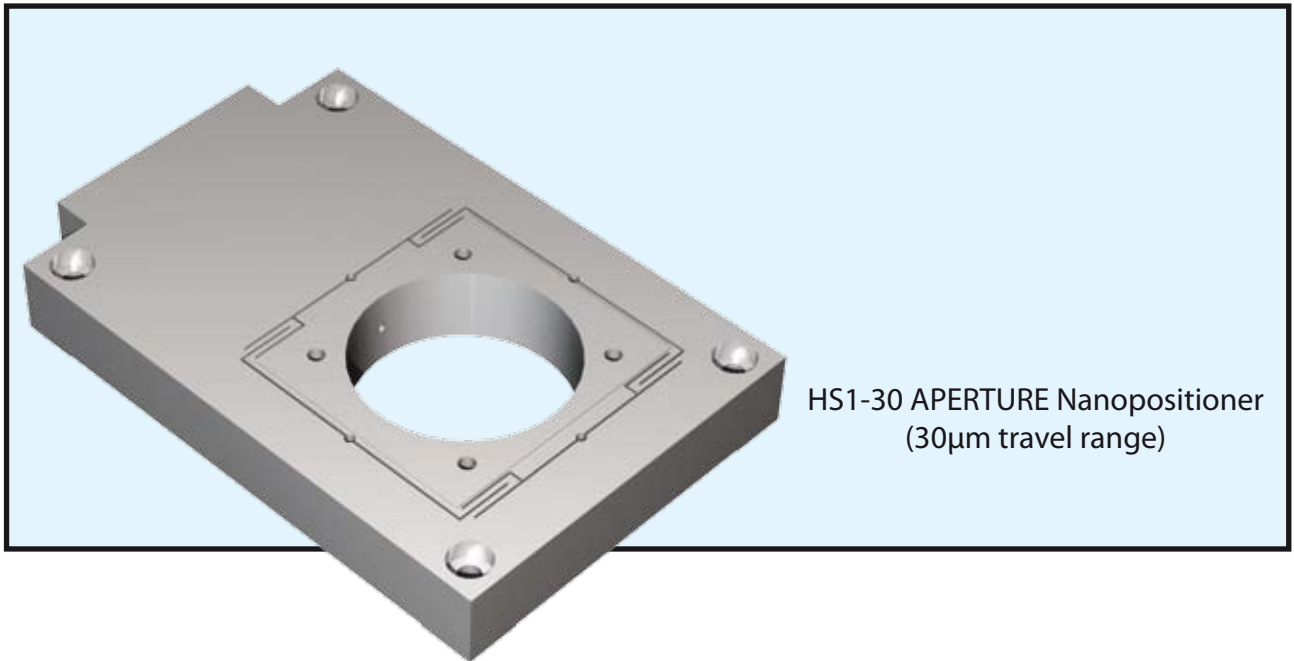

Features

- High speed, direct drive
- Diameter of the aperture : 33mm
- Stackable for XY or XYZ motion
- 30, 50 or 70 μ m motion
- Closed loop control
- Silicon sensor technology
- Less than 10pm noise floor

Applications

- Interferometry
- Nanolithography
- 3D polymerisation
- High speed focusing
- Adaptative optics

Specifications

	HS1.30 APERTURE	HS1.50 APERTURE	HS1.70 APERTURE
Range of motion (μm)	30	50	70
Resolution (nm)	0,03	0,05	0,07
Typical noise floor (nm)	0,003	0,005	0,007
Full range repeatability (nm)	0,06	0,1	0,14
Linearization (typical)	0,02%	0,02%	0,02%
Resonant frequency (Hz)	4000	4000	4000
Stiffness ($\text{N}/\mu\text{m}$)	3	3	3
Maximum load (kg) - horizontal use	1	1	1
Maximum load (kg) - vertical use	0,5	0,5	0,5
Sensor	Silicon HR sensor	Silicon HR sensor	Silicon HR sensor
Size W x L x H (mm)	62,5 x 96,10 x 12,6	62,5 x 116,10 x 12,6	62,5 x 138,10 x 12,6
Material	Al	Al	Al
Cable length (m)	2	2	2
Recommended Controller	Standard or High Speed	Standard or High Speed	Standard or High Speed

Drawing

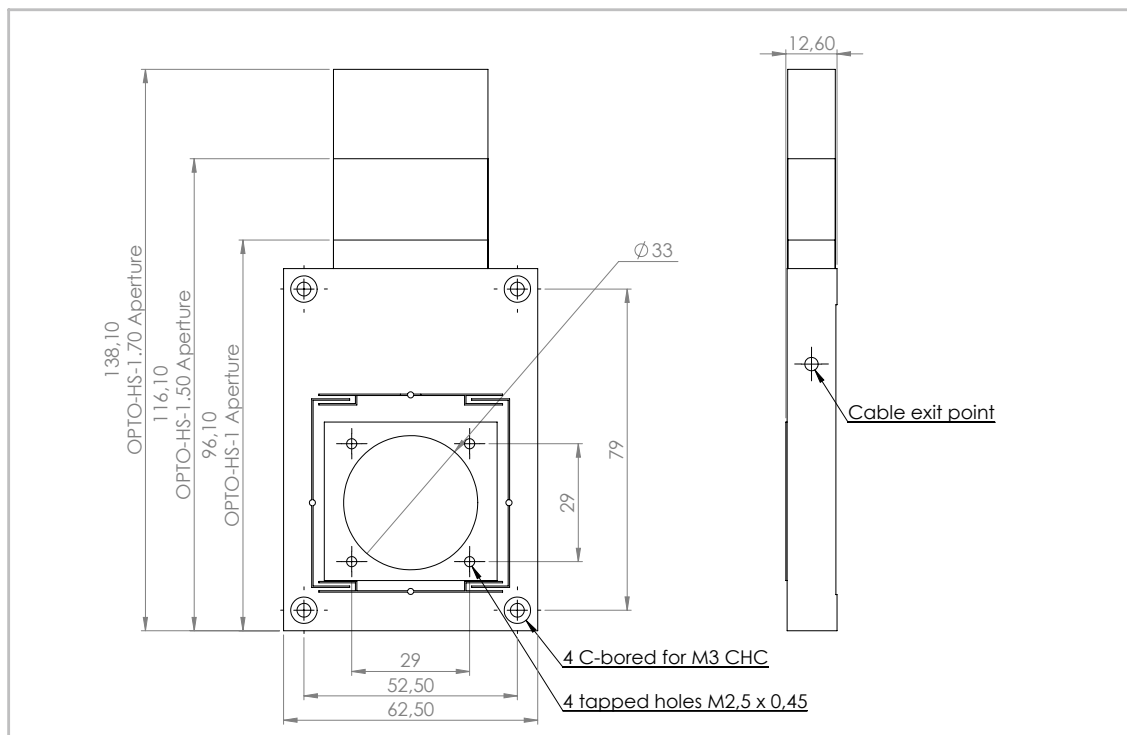

FOC NANOPositionER

The FOC are nanopositioners dedicated to microscope objective accurate positioning. They are offered with 100, 200 or 300 microns of travel. The FOC is used in a wide range of applications : Z-stack, automated focus or together with automated focus drift compensation system. It is made from aluminium and brass, and is equipped with sensor offering stability in the picometer level. The brass mounting ring can be easily exchanged so that any objective can be used with the FOC nanopositioner. The threads which are available are : RMS, M25, M26, M27 and M32.

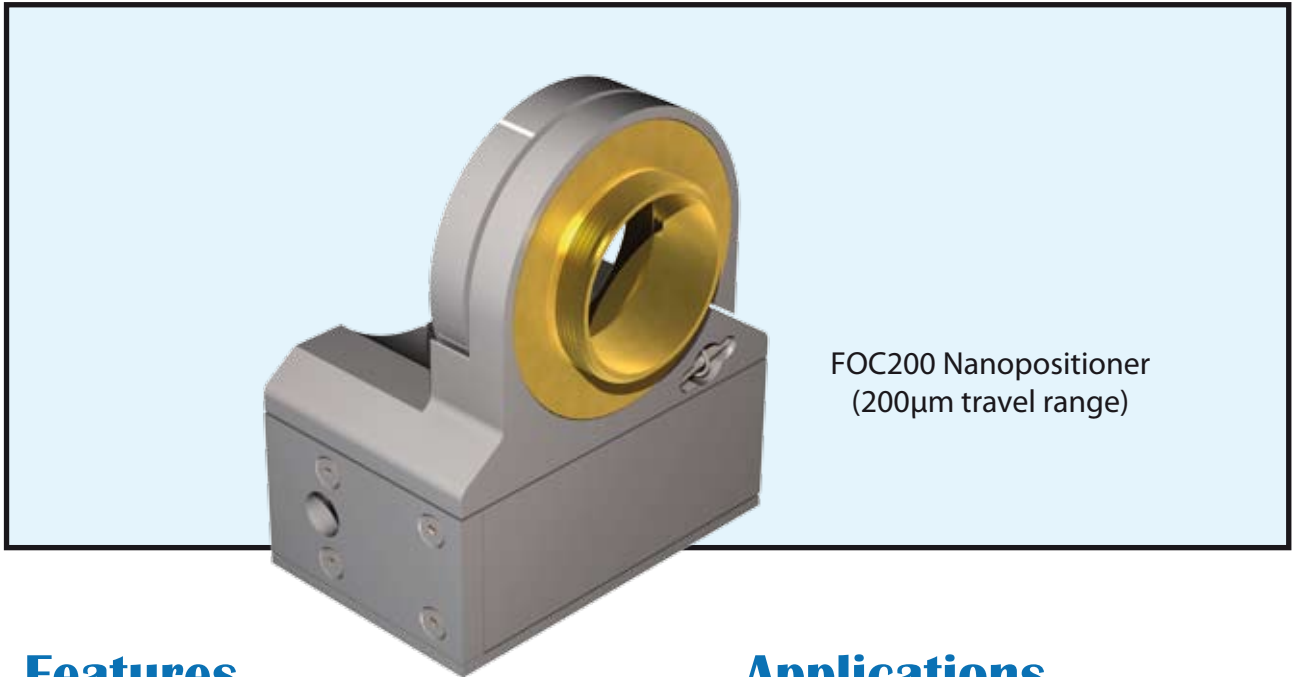

FOC200 Nanopositioner
(200 μ m travel range)

Features

- Travel ranges up to 300 μ m
- Moves objectives with sub-nm resolution
- Parallel flexure guiding
- Closed loop control
- Silicon sensor technology
- Less than 30pm noise floor

Applications

- 3D imaging
- Interferometry
- Autofocus system
- Confocal microscopy
- Super Resolution microscopy
- Semiconductor metrology

Specifications

	FOC100	FOC200	FOC300
Range of motion (μm)	100	200	300
Resolution (nm)	0,1	0,2	0,3
Typical noise floor (nm)	0,01	0,02	0,03
Full range repeatability (nm)	0,2	0,4	0,6
Linearization (typical)	0,02%	0,02%	0,02%
Resonant frequency (Hz)	500	350	250
Stiffness ($\text{N}/\mu\text{m}$)	0,6	0,4	0,3
Maximum load (kg) - horizontal use	0,5	0,5	0,5
Maximum load (kg) - vertical use	0,5	0,5	0,5
Sensor	Silicon HR sensor	Silicon HR sensor	Silicon HR sensor
Size W x L x H (mm)	53,6 x 64,2 x 34,50	53,6 x 64,2 x 34,50	53,6 x 64,2 x 34,50
Material	Al	Al	Al
Cable length (m)	2	2	2
Recommended Controller	Standard	Standard	Standard

Drawing

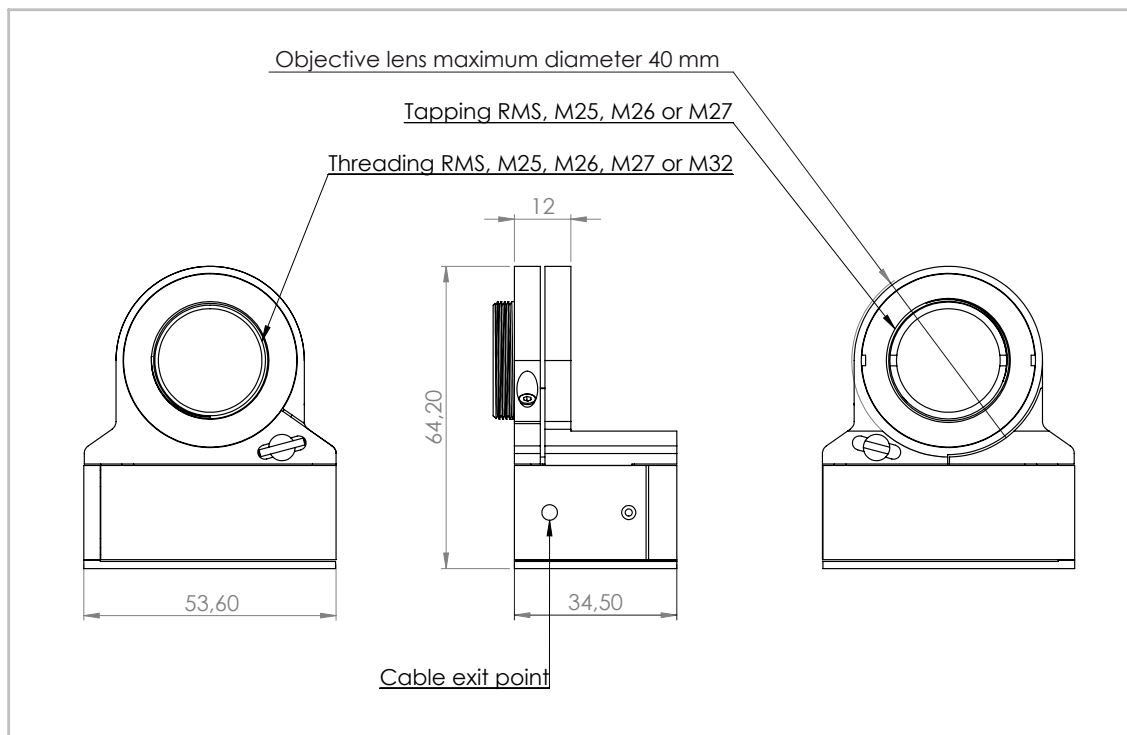

Z-INSERT NANOPositionNER

The Z insert is a low profile (19mm) Z stage that can be integrated into most of the standard long-range microstages dedicated to inverted or upright microscopes.

This stage is proposed in various travel ranges : 100, 200 and 300 microns and is provided with the sample holder of your choice (35mm Petri dish, coverslip or microscope slide).

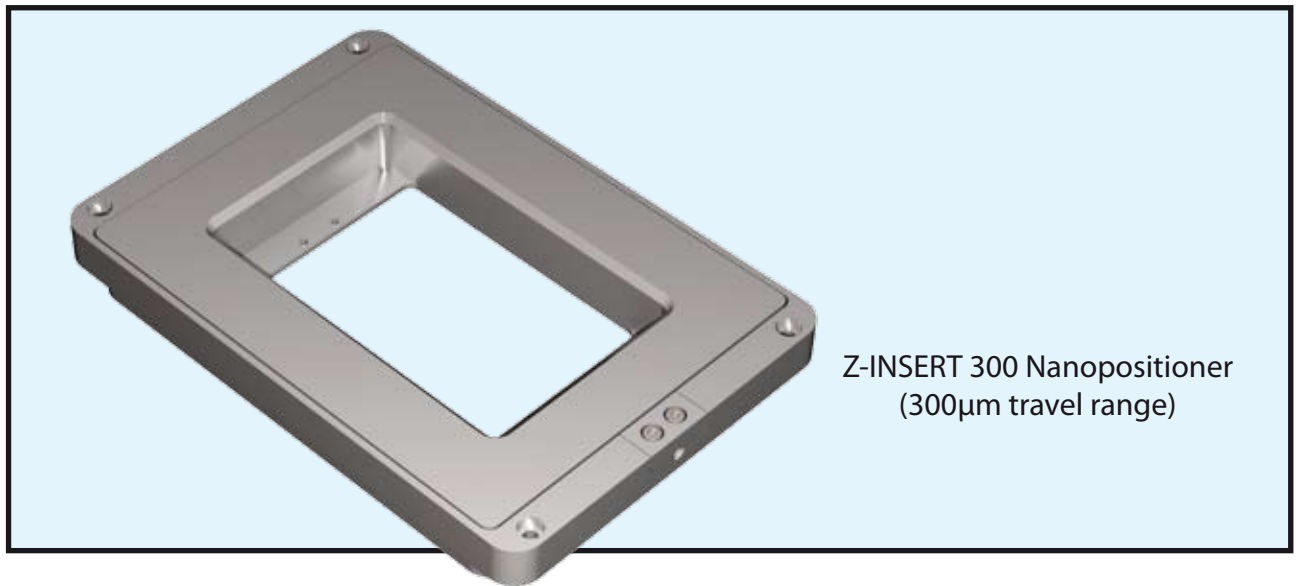

Features

- Travel ranges up to 300 μ m
- Low profile for easy integration
- Closed loop control
- Silicon sensor technology
- Less than 30pm noise floor

Applications

- Z-stack
- Autofocus system
- Confocal microscopy
- Super Resolution microscopy
- Biotechnology

Specifications

	Z-INSERT 100	Z-INSERT 200	Z-INSERT 300
Range of motion (μm)	100	200	300
Resolution (nm)	0,1	0,2	0,3
Typical noise floor (nm)	0,01	0,02	0,03
Full range repeatability (nm)	0,2	0,4	0,6
Linearization (typical)	0,02%	0,02%	0,02%
Resonant frequency (Hz)	500	450	350
Stiffness ($\text{N}/\mu\text{m}$)	0,6	0,6	0,4
Maximum load (kg) - horizontal use	1	1	1
Maximum load (kg) - vertical use	0,5	0,5	0,5
Sensor	Silicon HR sensor	Silicon HR sensor	Silicon HR sensor
Size W x L x H (mm)	109,80 x 159,80 x 19,10	109,80 x 159,80 x 19,10	109,80 x 159,80 x 19,10
Material	Al	Al	Al
Cable length (m)	2	2	2
Recommended Controller	Standard	Standard	Standard

Drawing

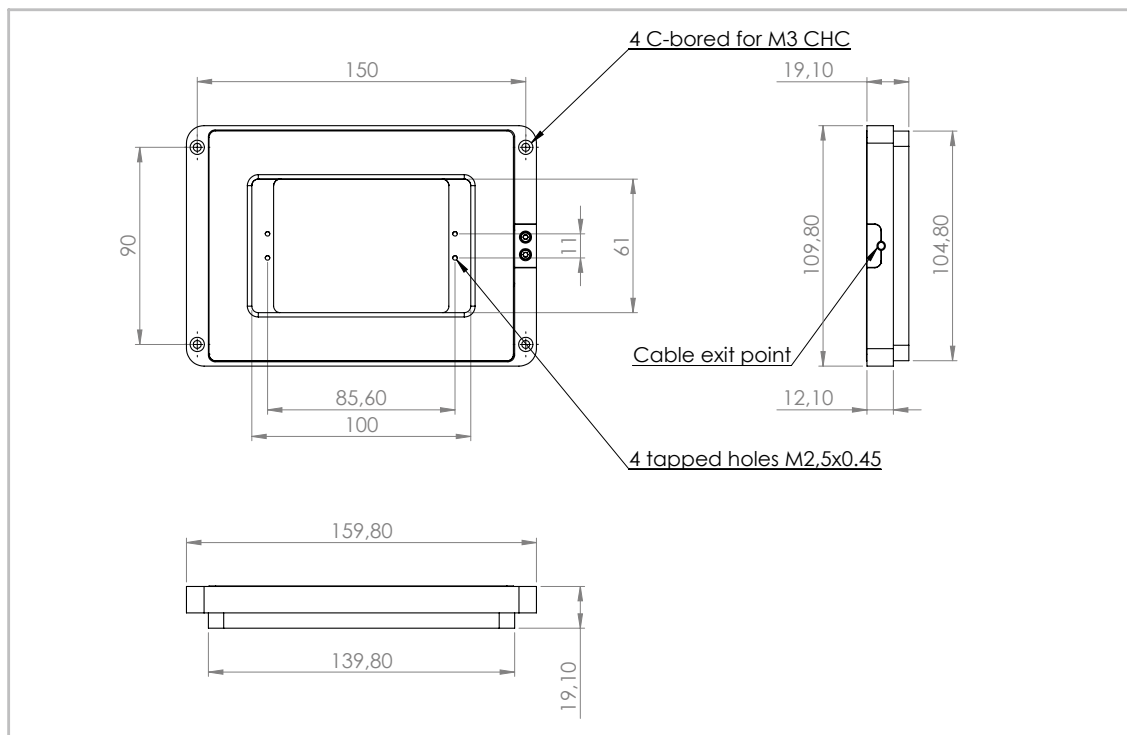

BIO2 NANOPositionER

The BIO 2 is a 2-axis ultra-low profile nanopositioner designed to be integrated in any kind of inverted microscopes. Microscope slides can be accommodated inside its rectangular aperture. This piezostage can be proposed with a coarse positioning Microstage (See our Hybrid System - pages 34-35).

As standard, the BIO2 is made in Aluminium but for Bruker AFM upgrade, we can propose the BIO2.100 (100 μ m version) in Invar, which leads to higher thermal stability.

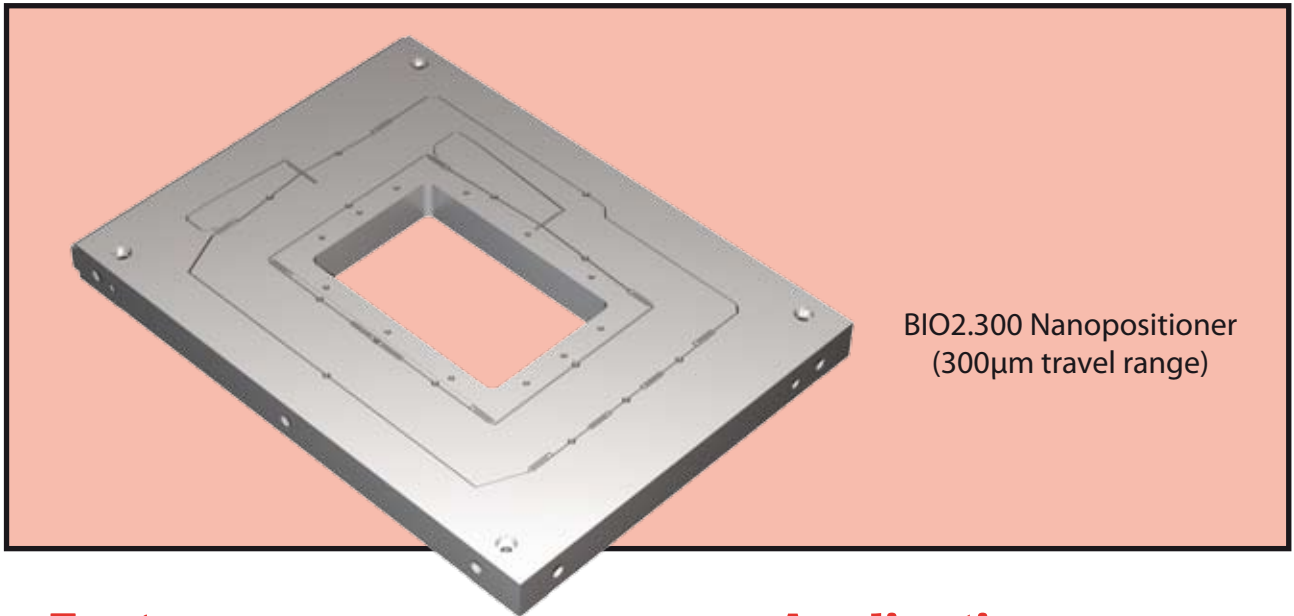

Features

- Low profile
- Rectangular aperture (83mm x 53mm)
- 100, 200 or 300 μ m motion
- Closed loop control
- Silicon sensor technology
- Less than 30pm noise floor

Applications

- Super Resolution microscopy
- Nanolithography
- Particle tracking
- Confocal microscopy
- Atomic Force Microscopy
- Bruker AFM upgrade

Specifications

	BIO2.100	BIO2.200	BIO2.300
Range of motion XY (μm)	100	200	300
Resolution XY (nm)	0,1	0,2	0,3
Typical noise floor XY (nm)	0,01	0,02	0,03
Full range repeatability XY (nm)	0,2	0,4	0,6
Linearization (typical)	0,02%	0,02%	0,02%
Resonant frequency X/Y (Hz)	500/400	400/350	300/250
Stiffness (N/ μm)	0,6/0,5	0,5/0,4	0,4/0,3
Maximum load (kg) - horizontal use	1	1	1
Maximum load (kg) - vertical use	0,5	0,5	0,5
Sensor	Silicon HR sensor	Silicon HR sensor	Silicon HR sensor
Size W x L x H (mm)	206,5 x 152,5 x 15,6	206,5 x 152,5 x 15,6	206,5 x 152,5 x 15,6
Material	Al or Invar	Al	Al
Cable length (m)	2	2	2
Recommended Controller	Standard	Standard	Standard

Drawing

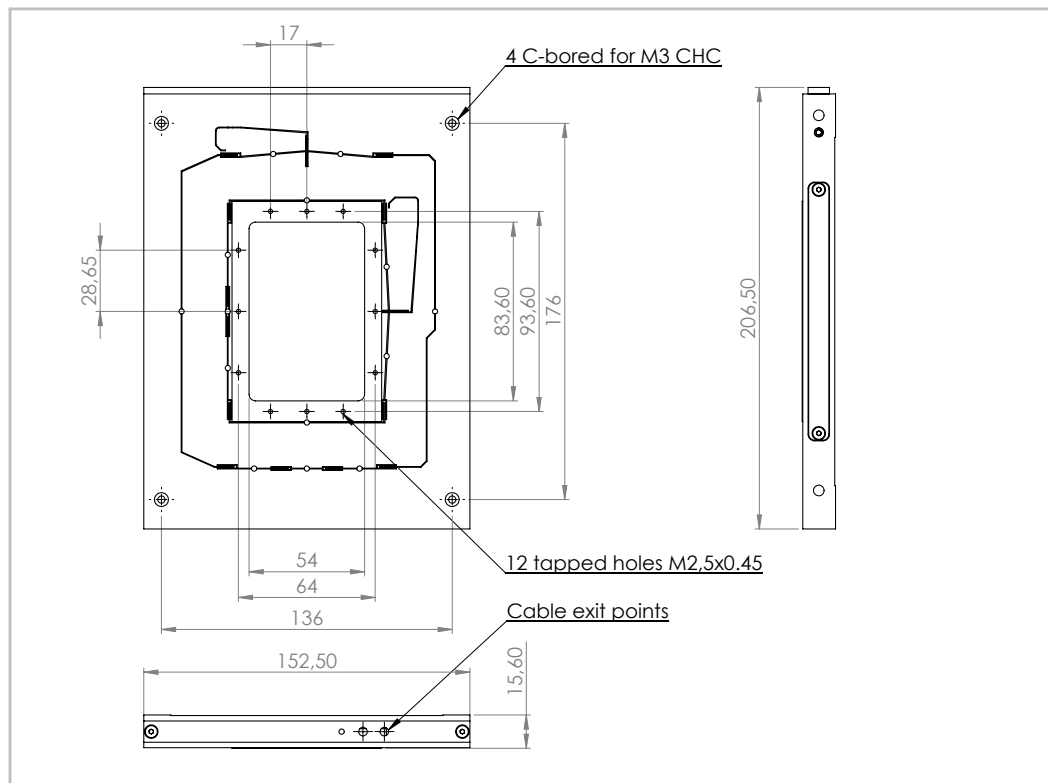

LT2 NANOPositionER

The LT2 is a 2-axis ultra-low profile nanopositioner designed to be integrated in any kind of inverted microscopes. This piezostage can be proposed with a coarse positioning Microstage (See our Hybrid System - pages 34-35).

As standard, the LT2 is made in Aluminium but for Bruker AFM upgrade, we can propose the LT2.100 (100 μ m version) in Invar, which leads to higher thermal stability.

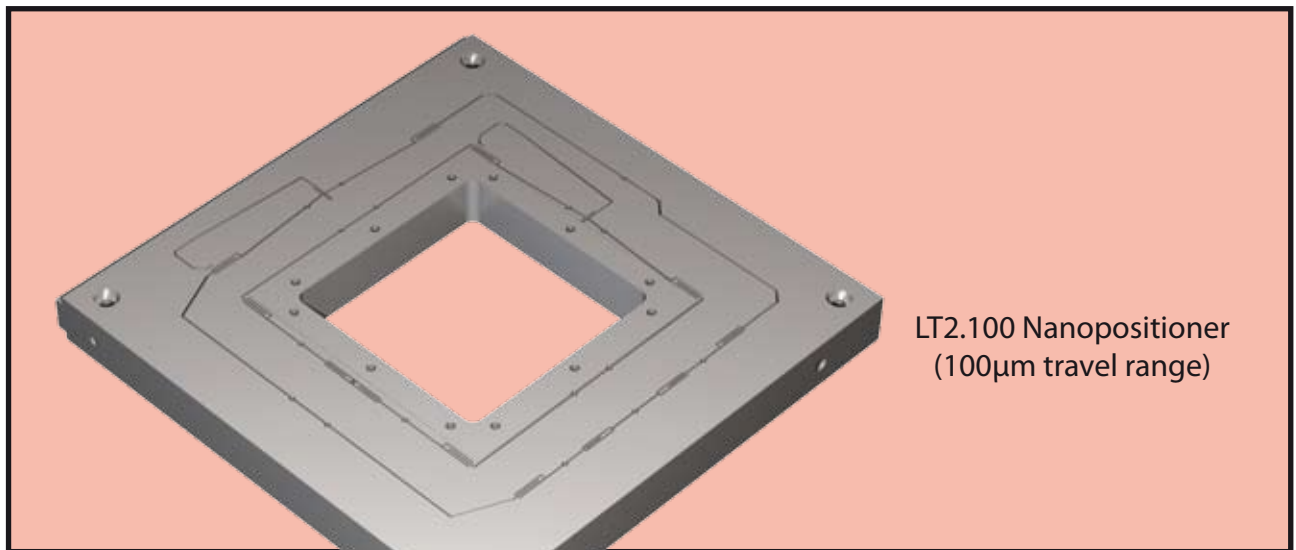

Features

- Low profile
- Square aperture (66mm x 66mm)
- 100, 200 or 300 μ m motion
- Closed loop control
- Silicon sensor technology
- Less than 30pm noise floor

Applications

- Super Resolution microscopy
- Nanolithography
- Particle tracking
- Confocal microscopy
- Atomic Force Microscopy
- Bruker AFM upgrade

Specifications

	LT2.100	LT2.200	LT2.300
Range of motion XY (μm)	100	200	300
Resolution XY (nm)	0,1	0,2	0,3
Typical noise floor XY (nm)	0,01	0,02	0,03
Full range repeatability XY (nm)	0,2	0,4	0,6
Linearization (typical)	0,02%	0,02%	0,02%
Resonant frequency X/Y (Hz)	500/400	400/350	300/250
Stiffness (N/ μm)	0,6/0,5	0,5/0,4	0,4/0,3
Maximum load (kg) - horizontal use	1	1	1
Maximum load (kg) - vertical use	0,5	0,5	0,5
Sensor	Silicon HR sensor	Silicon HR sensor	Silicon HR sensor
Size W x L x H (mm)	155,5 x 152,5 x 15,5	155,5 x 152,5 x 15,5	155,5 x 152,5 x 15,5
Material	Al or Invar	Al	Al
Cable length (m)	2	2	2
Recommended Controller	Standard	Standard	Standard

Drawing

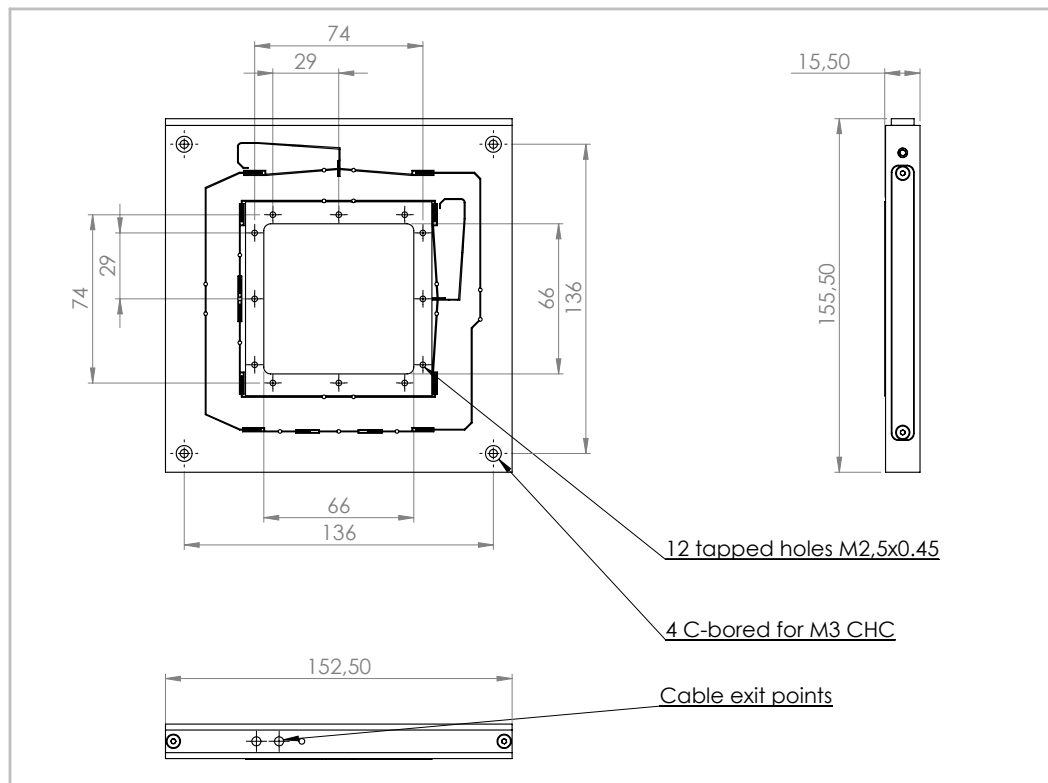

LFHS2 NANOPositionER

The LFHS2 is a 2-axis ultra-high speed nanopositioner, offering a motion range of 75µm along X and Y, a large 66mm x 66mm aperture and resonant frequencies higher than 2kHz on both axis. It can be also proposed with an integrated Z axis (50µm travel range) if required (see the LFHS3 - pages 28-29) . This piezostage can be proposed with a coarse positioning Microstage (See our Hybrid System - pages 34-35). This nanopositioner is part of our high-speed product line (High power controller available). High speed scans and step response time smaller than 2ms are then possible.

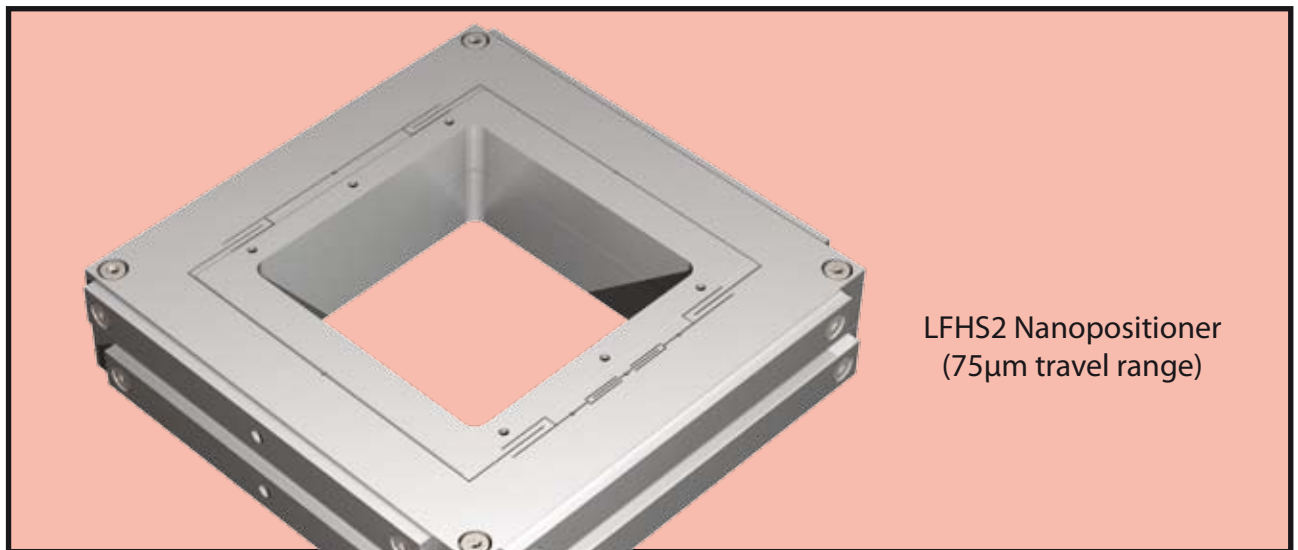

LFHS2 Nanopositioner
(75µm travel range)

Features

- Ultra high speed
- Direct drive
- Square aperture (66mm x 66mm)
- 75µm XY motion
- Closed loop control
- Silicon sensor technology
- Less than 10pm noise floor

Applications

- Super Resolution microscopy
- Particle tracking
- Fast XY scanning
- Confocal microscopy
- Atomic Force Microscopy
- Optical tweezer

Specifications

	LFHS2
Range of motion XY (μm)	75
Resolution XY (nm)	0,075
Typical noise floor XY (nm)	0,0075
Full range repeatability XY (nm)	0,15
Linearization (typical)	0,02%
Resonant frequency X/Y (Hz)	3000/2000
Stiffness (N/ μm)	4/3
Maximum load (kg) - horizontal use	1
Maximum load (kg) - vertical use	0,5
Sensor	Silicon HR sensor
Size W x L x H (mm)	120,8 x 120,7 x 28,5
Material	Al
Cable length (m)	2
Recommended Controller	High Speed

Drawing

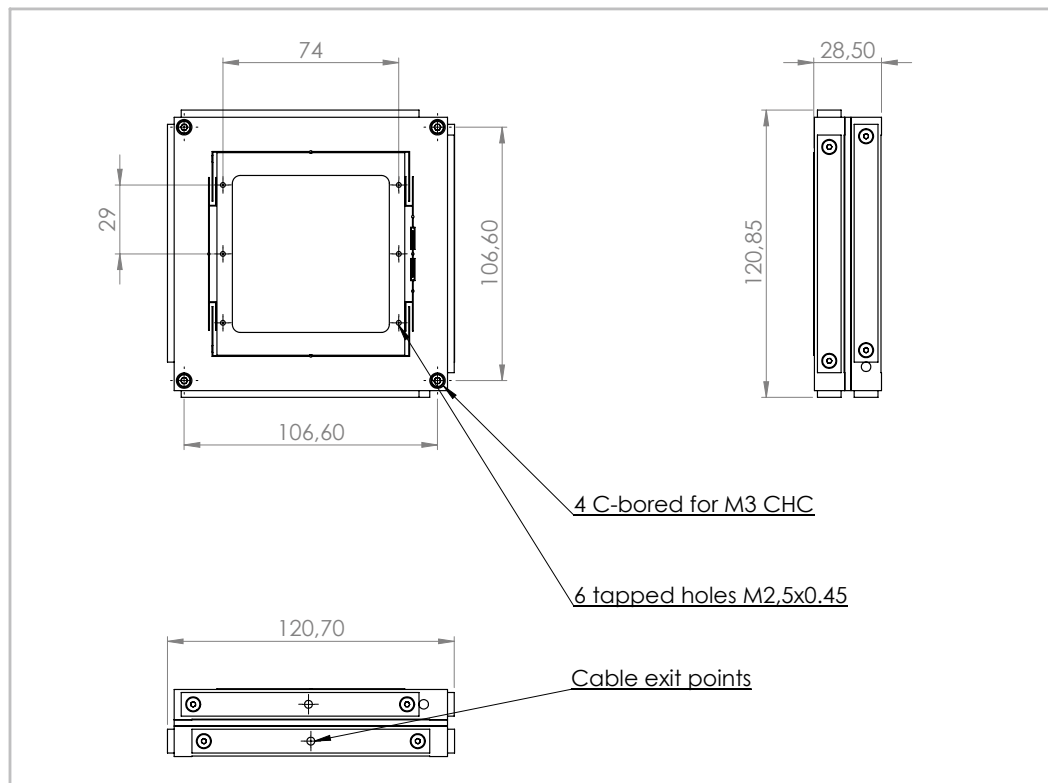

LTHS2 NANOPositionER

The LTHS2 is a 2-axis ultra-high speed nanopositioner, offering a motion range of 75µm along X and Y and a large 83mm x 66mm aperture well compatible with microscope slides. Its resonant frequencies higher than 1kHz on both axis allows high-speed XY scans. This nanopositioner is part of our high-speed product line (High power controller available). High speed scans and step response time smaller than 2ms are then possible. If a low footprint is not required, the LFHS2 can be an interesting alternative solution (See pages 18-19). This piezostage can be proposed with a coarse positioning Microstage (See pages 34-35).

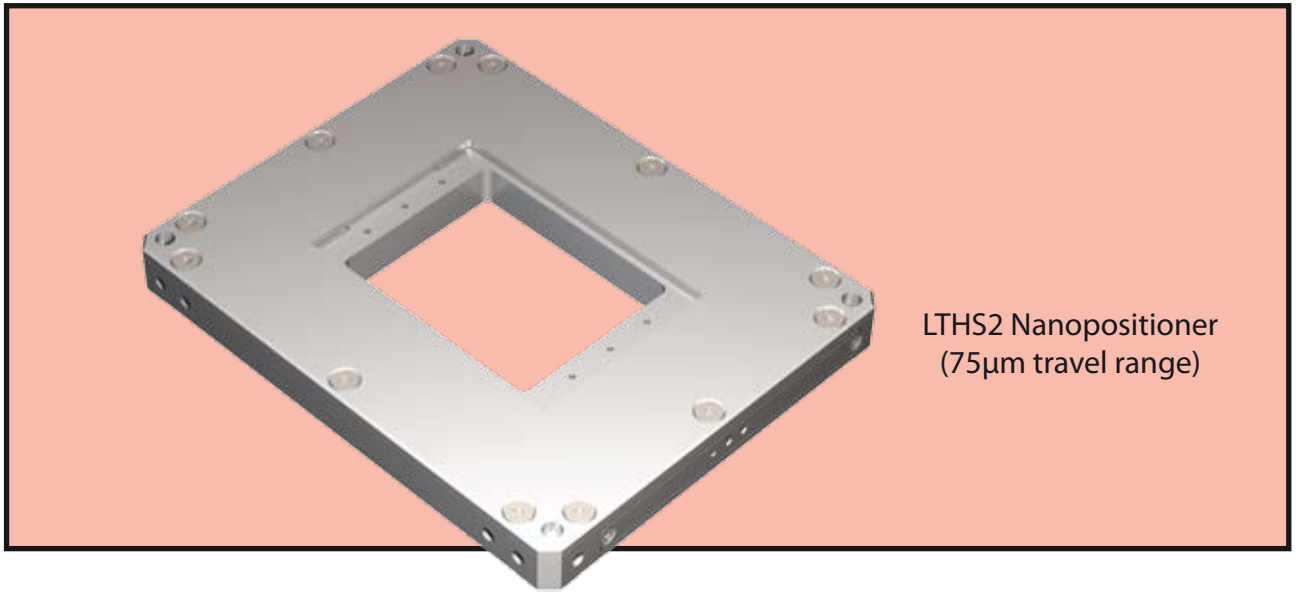

Features

- Ultra high speed
- Direct drive
- Rectangular aperture (83mm x 66mm)
- 75µm XY motion
- Closed loop control
- Silicon sensor technology
- Less than 10pm noise floor

Applications

- Super Resolution microscopy
- Particle tracking
- Fast XY scanning
- Confocal microscopy
- Atomic Force Microscopy
- Optical tweezer

Specifications

	LTHS2
Range of motion XY (μm)	75
Resolution XY (nm)	0,075
Typical noise floor XY (nm)	0,0075
Full range repeatability XY (nm)	0,15
Linearization (typical)	0,02%
Resonant frequency X/Y (Hz)	1500/1000
Stiffness (N/ μm)	2/2
Maximum load (kg) - horizontal use	0,5
Maximum load (kg) - vertical use	0,3
Sensor	Silicon HR sensor
Size W x L x H (mm)	152,5 x 190 x 18,5
Material	Al
Cable length (m)	2
Recommended Controller	Standard or High Speed

Drawing

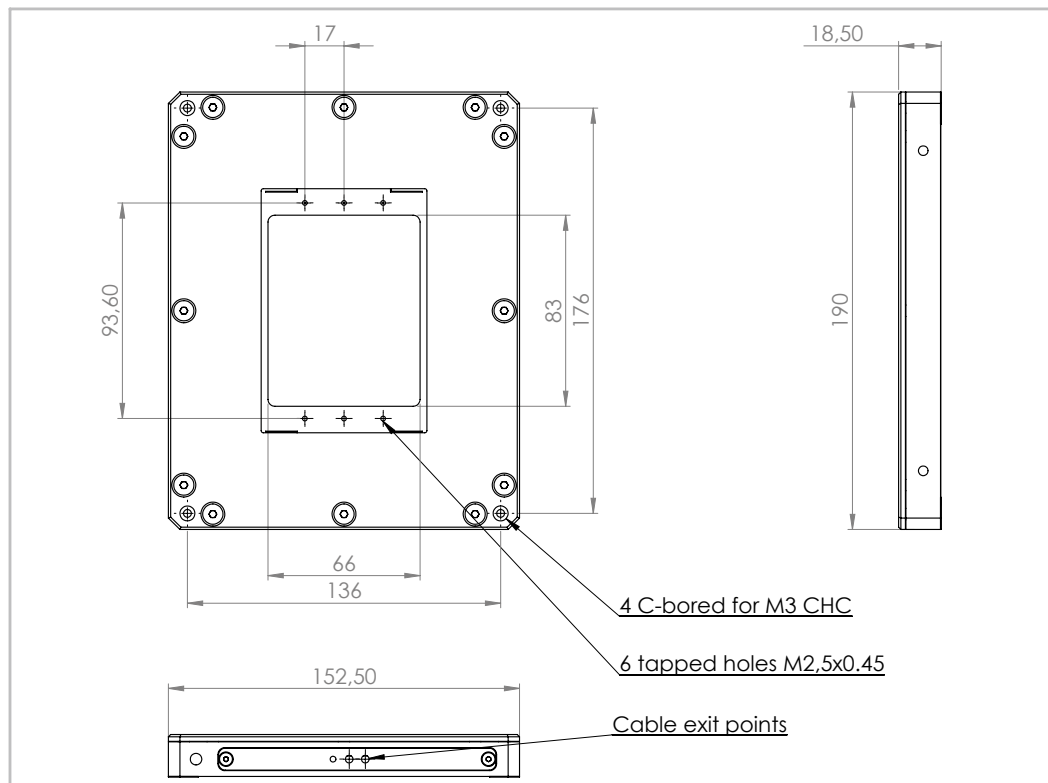

TT2 NANOPositionER

The TT2 is a 2-axis tip-tilt stage with a range of motion of 5 mrad (for each axis). This piezostage is the ideal tool for applications where an optical beam steering is necessary. This makes this high-speed stage a best-seller for application such as : particle tracking, optical tweezer, beam stabilization and scanning microscopy. This nanopositioner is part of our high-speed product line (High power controller available). High speed scan at 500Hz and step response time smaller than 2ms are then possible.

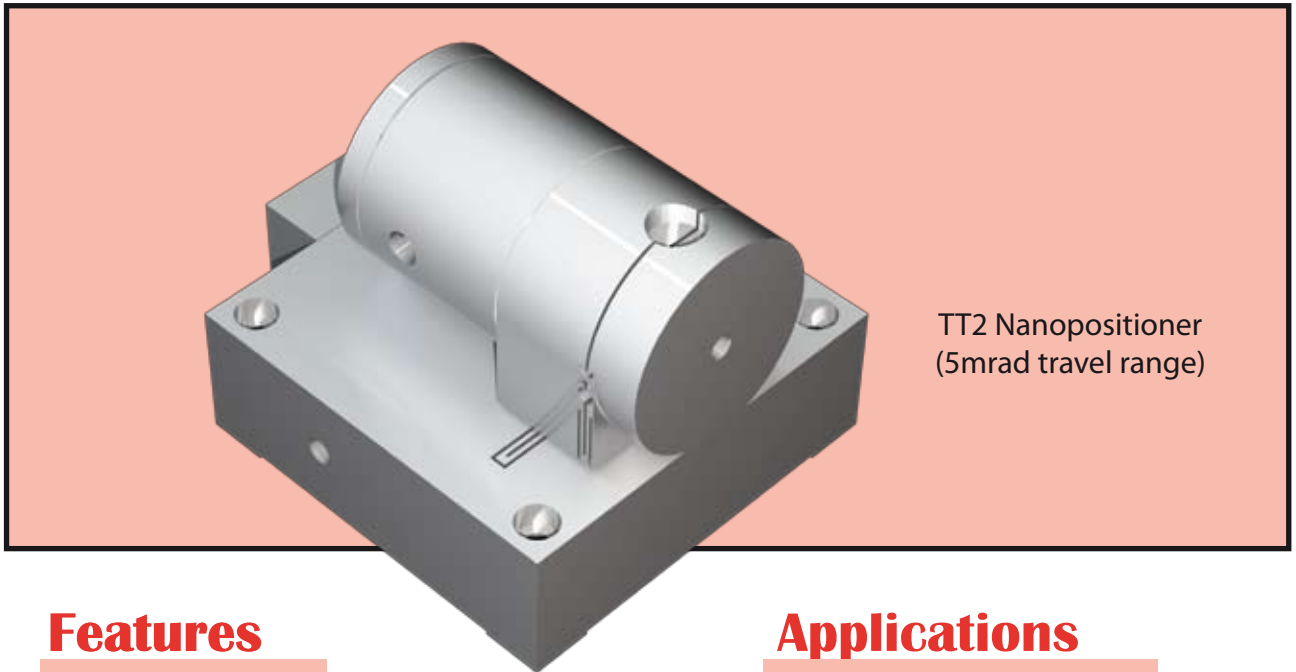

Features

- Ultra high speed
- 1 inch mirror mounting surface
- 5mrad Tip-Tilt motion
- Closed loop control
- Silicon sensor technology
- Less than 1nrad noise floor

Applications

- Beam stabilization
- Particle tracking
- Fast beam steering
- Confocal microscopy
- Optical tweezer
- TERS

Specifications

	TT2.5
Range of angular motion (mrad)	5
Angular resolution (μrad)	0,005
Typical angular noise floor (μrad)	0,0005
Full range repeatability (μrad)	0,01
Linearization (typical)	0,02%
Resonant frequency Tip/Tilt (Hz)	4000/2000
Stiffness (N/ μm)	N/A
Maximum load (kg) - horizontal use	0,2
Maximum load (kg) - vertical use	0,2
Sensor	Silicon HR sensor
Size W x L x H (mm)	51 x 60,5 x 43,2
Material	Al
Cable length (m)	2
Recommended Controller	Standard or High Speed

Drawing

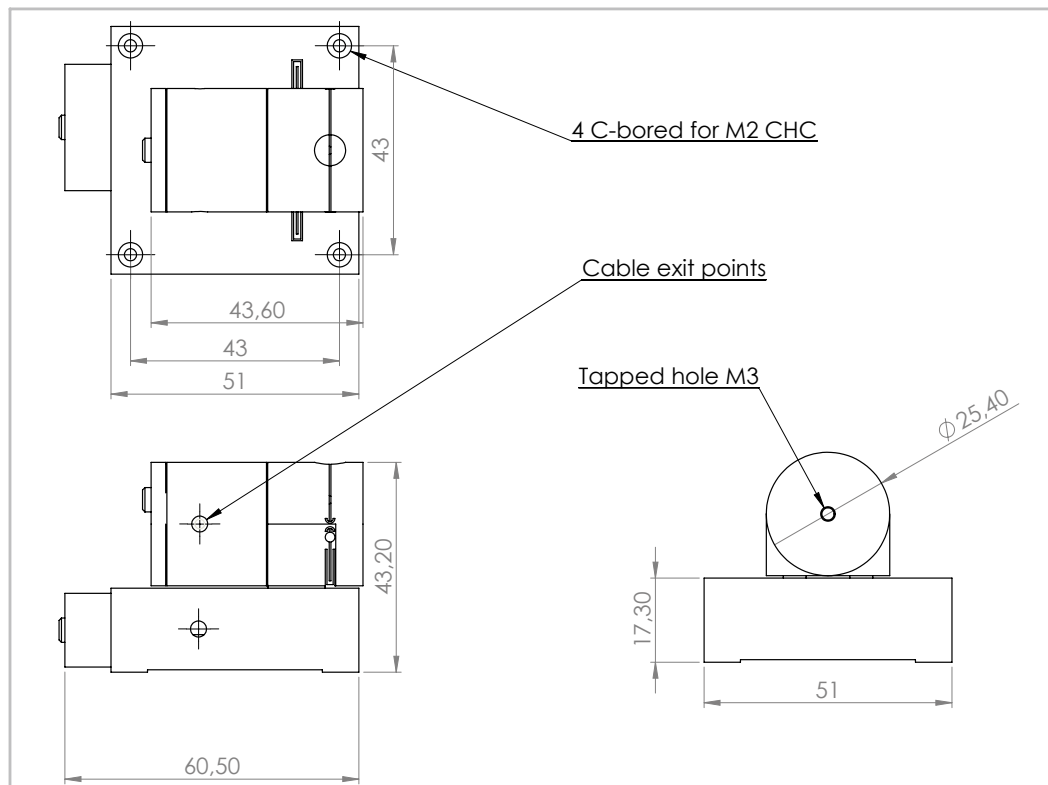

BIO3 NANOPositionER

The BIO3 is a 3-axis ultra-low profile nanopositioner designed to be integrated in any kind of inverted microscopes. Microscope slides can be accommodated inside its rectangular aperture. This piezostage can be proposed with a coarse positioning Microstage (See our Hybrid System - pages 34-35).

As standard, the BIO3 is made in Aluminium but for Bruker AFM upgrade, we can propose the BIO3.100 (100 μ m version) also in Invar, which leads to higher thermal stability.

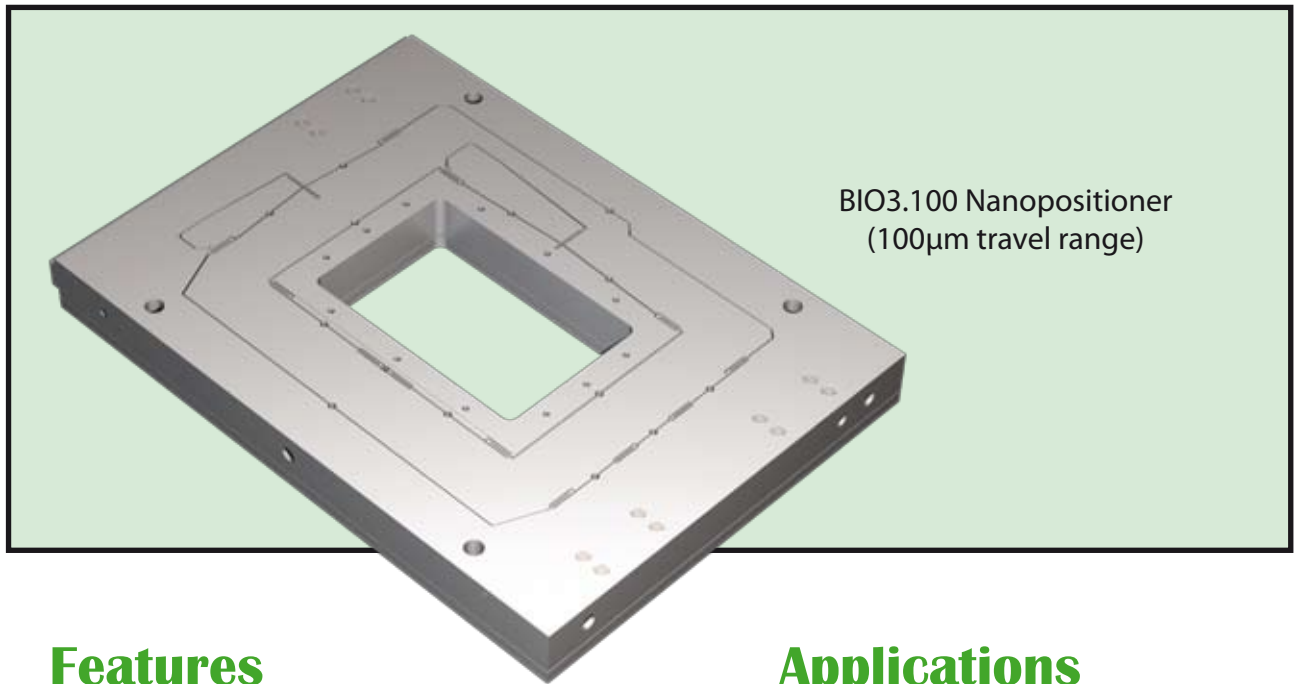

Features

- Low profile
- Rectangular aperture (83mm x 53mm)
- 100, 200 or 300 μ m motion
- Closed loop control
- Silicon sensor technology
- Less than 30pm noise floor

Applications

- Super Resolution microscopy
- Nanolithography
- Particle tracking
- Confocal microscopy
- Atomic Force Microscopy
- Bruker AFM upgrade

Specifications

	BIO3.100	BIO3.200	BIO3.300
Range of motion XYZ (μm)	100	200	300
Resolution XYZ (nm)	0,1	0,2	0,3
Typical noise floor XYZ (nm)	0,01	0,02	0,03
Full range repeatability XYZ (nm)	0,2	0,4	0,6
Linearization (typical)	0,02%	0,02%	0,02%
Resonant frequency X/Y/Z (Hz)	500/400/400	400/350/300	300/250/250
Stiffness X/Y/Z (N/ μm)	0,6/0,5/0,5	0,5/0,4/0,4	0,4/0,3/0,3
Maximum load (kg) - horizontal use	1	1	1
Maximum load (kg) - vertical use	0,5	0,5	0,5
Sensor	Silicon HR sensor	Silicon HR sensor	Silicon HR sensor
Size W x L x H (mm)	152,5 x 213 x 20,45	152,5 x 213 x 20,45	152,5 x 213 x 20,45
Material	Al or Invar	Al	Al
Cable length (m)	2	2	2
Recommended Controller	Standard	Standard	Standard

Drawing

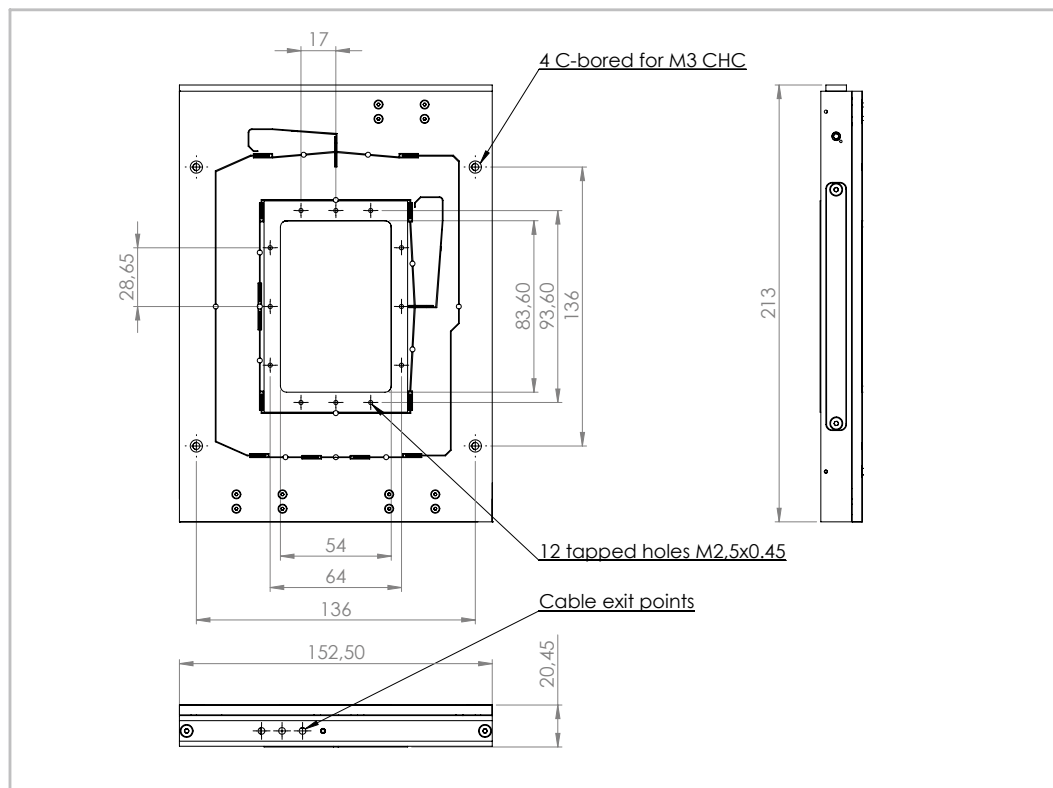

LT3 NANOPositionER

The LT3 is a 3-axis ultra-low profile nanopositioner primarily designed to be integrated in any kind of inverted microscopes. This piezostage can be proposed with a coarse positioning Microstage (See our Hybrid System - page 34-35).

As standard, the LT3 is made in Aluminium but for Bruker AFM upgrade, we can propose the LT3.100 (100 μ m version) in Invar, which leads to higher thermal stability.

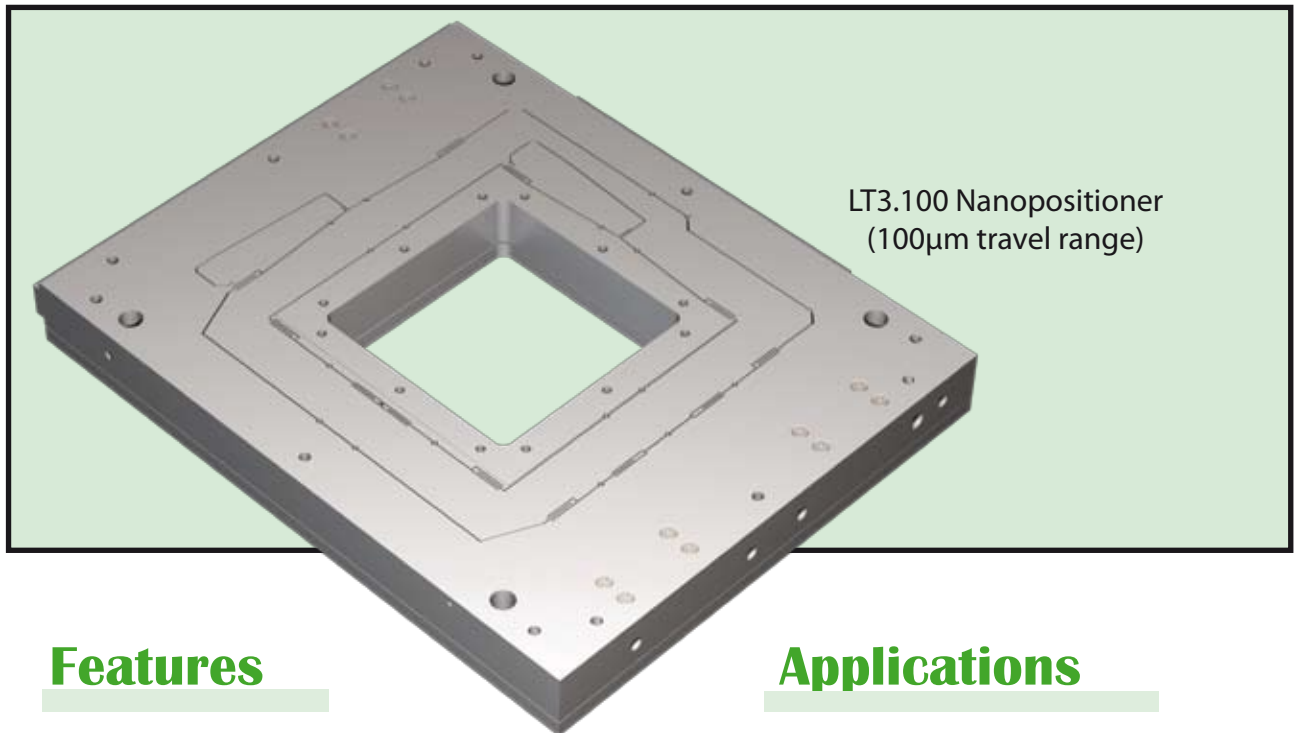

Features

- Low profile
- Square aperture (66mm x 66mm)
- 100, 200 or 300 μ m motion
- Closed loop control
- Silicon sensor technology
- Less than 30pm noise floor

Applications

- Super Resolution microscopy
- Nanolithography
- Particle tracking
- Confocal microscopy
- Atomic Force Microscopy
- Bruker AFM upgrade

Specifications

	LT3.100	LT3.200	LT3.300
Range of motion XYZ (μm)	100	200	300
Resolution XYZ (nm)	0,1	0,2	0,3
Typical noise floor XYZ (nm)	0,01	0,02	0,03
Full range repeatability XYZ (nm)	0,2	0,4	0,6
Linearization (typical)	0,02%	0,02%	0,02%
Resonant frequency X/Y/Z (Hz)	500/400/400	400/350/300	300/250/250
Stiffness X/Y/Z (N/ μm)	0,6/0,5/0,5	0,5/0,4/0,4	0,4/0,3/0,3
Maximum load (kg) - horizontal use	1	1	1
Maximum load (kg) - vertical use	0,5	0,5	0,5
Sensor	Silicon HR sensor	Silicon HR sensor	Silicon HR sensor
Size W x L x H (mm)	152,5 x 193 x 20,70	152,5 x 193 x 20,70	152,5 x 193 x 20,70
Material	Al or Invar	Al	Al
Cable length (m)	2	2	2
Recommended Controller	Standard	Standard	Standard

Drawing

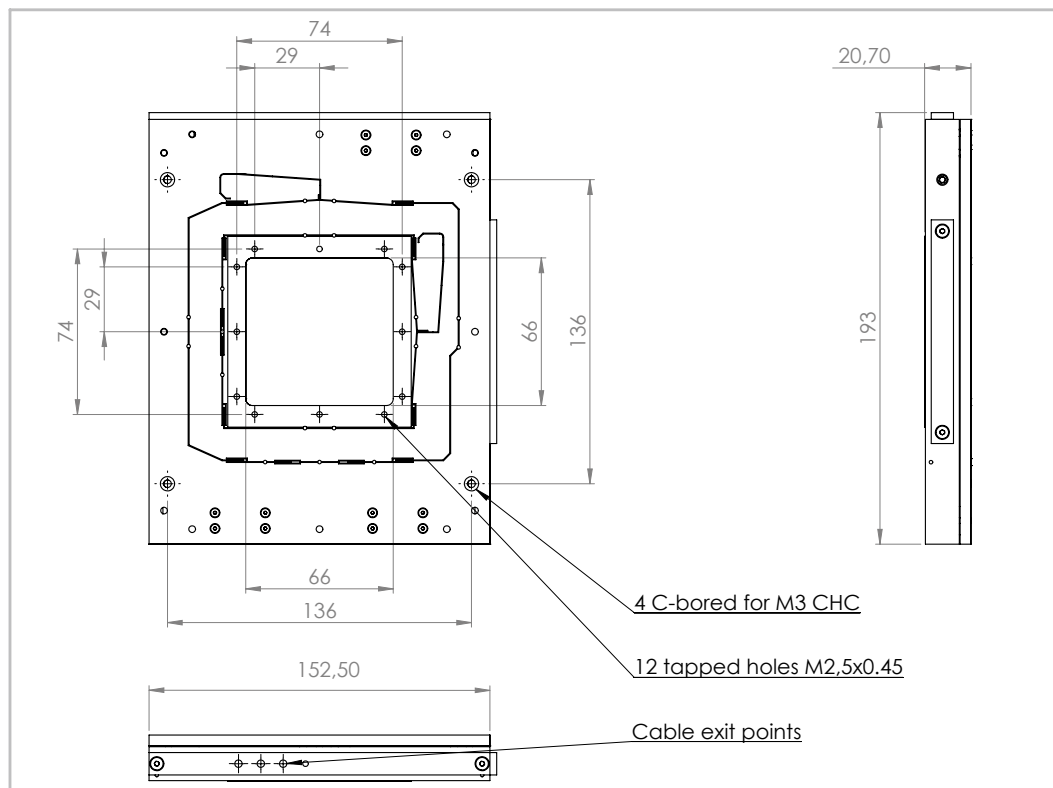

LFHS3 NANOPositionER

The LFHS3 is a 3-axis ultra-high speed nanopositioner, offering 75 μ m motion along X and Y, 50 μ m travel along Z, a large 66mm x 66mm aperture and resonant frequencies higher than 1.5kHz on every axis. This piezostage can be proposed with a coarse positioning Microstage (See our Hybrid System - pages 34-35). This nanopositioner is part of our high-speed product line (High power controller available). High speed scans and step response time smaller than 2ms are consequently possible.

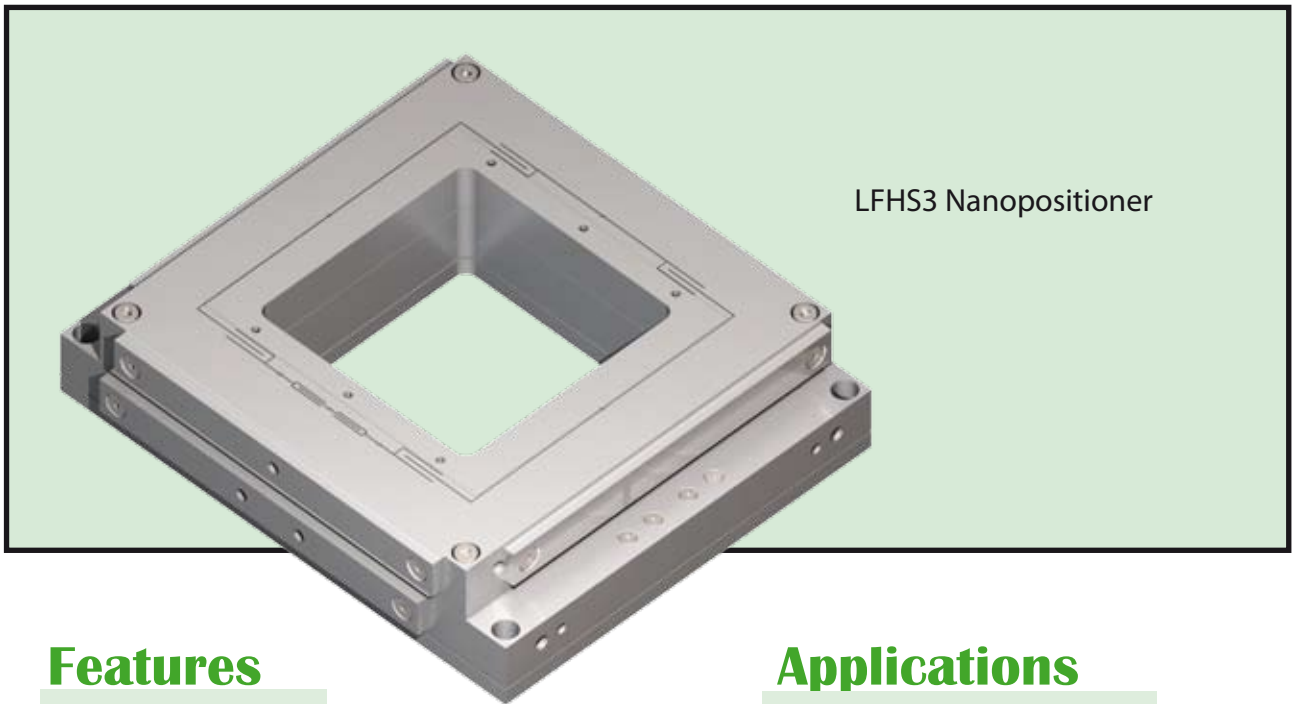

Features

- Ultra high speed
- Direct drive
- Square aperture (66mm x 66mm)
- 75 μ m XY motion, 50 μ m Z motion
- Closed loop control
- Silicon sensor technology
- Less than 10pm noise floor

Applications

- Super Resolution microscopy
- Particle tracking
- Fast XY scanning
- Confocal microscopy
- Atomic Force Microscopy
- Optical tweezer

Specifications

	LFHS3		
Range of motion X/Y/Z (μm)	75	75	50
Resolution X/Y/Z (nm)	0,075	0,075	0,05
Typical noise floor X/Y/Z (nm)	0,0075	0,0075	0,005
Full range repeatability X/Y/Z (nm)	0,15	0,15	0,1
Linearization (typical)	0,02%	0,02%	0,02%
Resonant frequency X/Y/Z (Hz)	3000	2000	1500
Stiffness X/Y/Z (N/μm)	4	3	3
Maximum load (kg) - horizontal use	1		
Maximum load (kg) - vertical use	0,5		
Sensor	Silicon HR sensor		
Size W x L x H (mm)	140 x 121 x 33,6		
Material	Al		
Cable length (m)	2		
Recommended Controller	High Speed		

Drawing

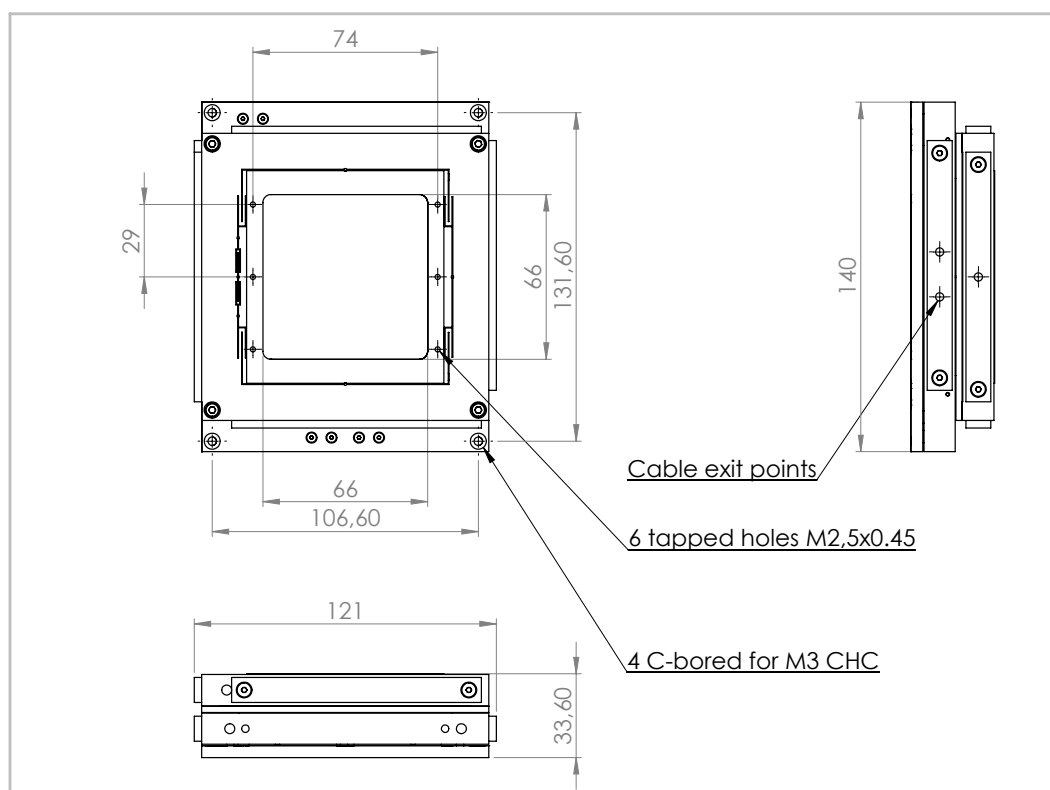

CUBE3 NANOPositionER

The CUBE3 is a 3-axis nanopositioner, offering either 100 or 200 μ m motion along X, Y and Z. Its compact design makes it the ideal tool for applications such as : optical fiber alignment, 2 photons polymerisation and laser writing.

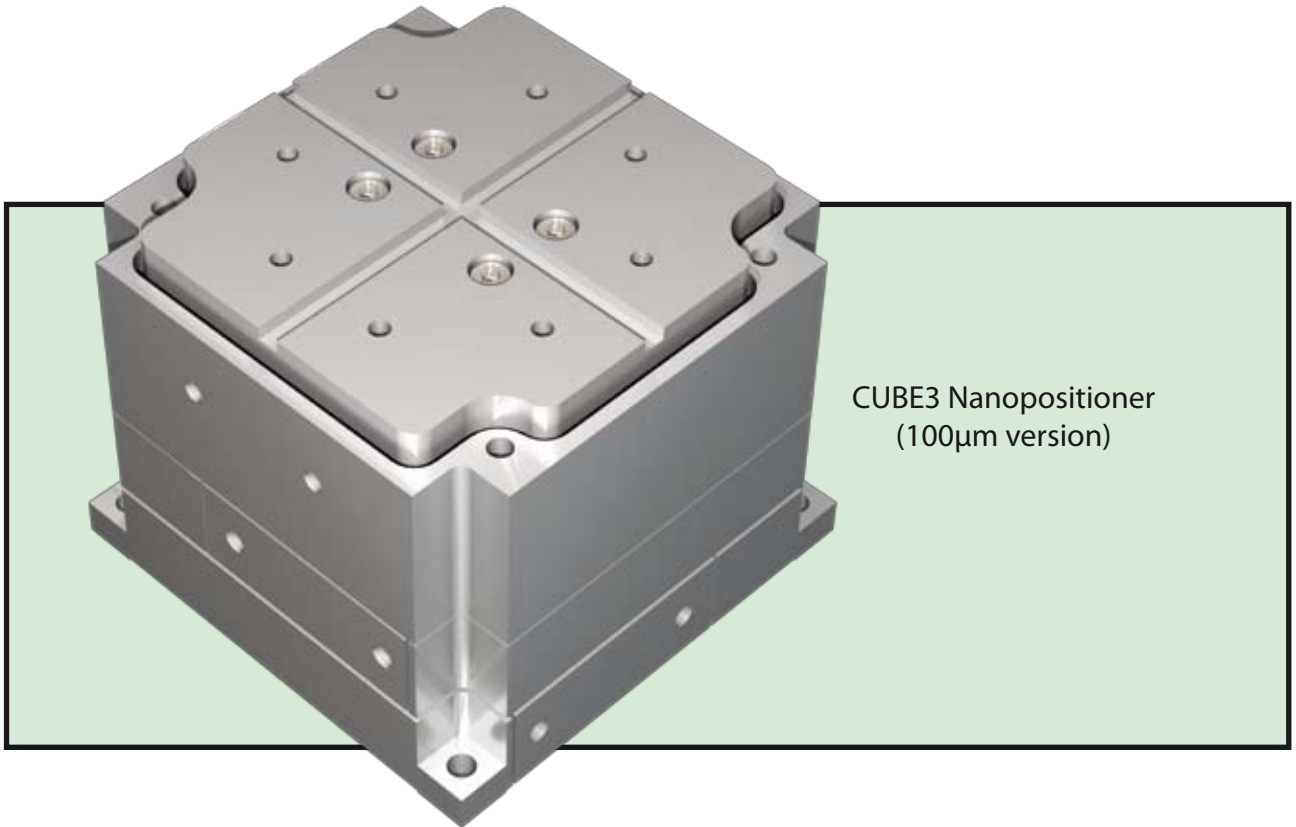

CUBE3 Nanopositioner
(100 μ m version)

Features

- 100 μ m or 200 μ m XYZ motion
- Compact design
- Closed loop control
- Silicon sensor technology
- Less than 30pm noise floor

Applications

- Alignment
- Laser writing
- 2 photons polymerisation
- Confocal microscopy
- 3D printer

Specifications

	CUBE3.100	CUBE3.200
Range of motion XYZ (μm)	100	200
Resolution XYZ (nm)	0,1	0,2
Typical noise floor XYZ (nm)	0,01	0,02
Full range repeatability XYZ (nm)	0,2	0,4
Linearization (typical)	0,02%	0,02%
Resonant frequency X/Y/Z (Hz)	200/200/500	200/200/500
Stiffness X/Y/Z (N/ μm)	0,3/0,3/0,6	0,3/0,3/0,6
Maximum load (kg) - horizontal use	0,5	0,5
Maximum load (kg) - vertical use	0,1	0,1
Sensor	Silicon HR sensor	Silicon HR sensor
Size W x L x H (mm)	63,5 x 63,5 x 52,45	63,5 x 63,5 x 52,45
Material	Al	Al
Cable length (m)	2	2
Recommended Controller	Standard	Standard

Drawing

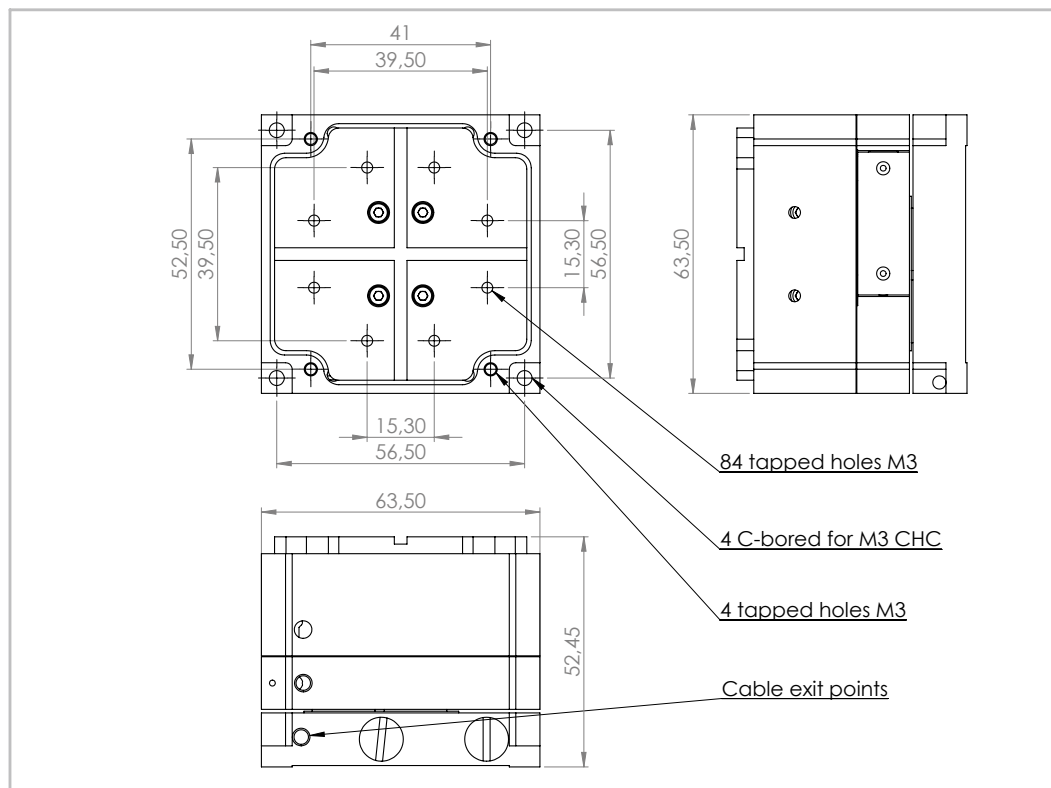

MANUAL MICROSTAGE

The manual Microstage we offer has been designed to be a very stable base for our nanopositioners. It offers 25mm travel along X and Y and it is proposed for any inverted microscopes (ZEISS, OLYMPUS, NIKON, LEICA). A blocking force of 20N has been implemented into this system so that it doesn't move at the nanometer level even if an high-speed piezostage oscillates on top of it. Standard Microstage are often not able to reach that performance (presence of oscillations or drifts). Optional wings or an optional breadboard (with threaded M6 holes on a 25mm pattern or 1/4-20 holes on a 1 inch pattern) can be also provided.



Features

- Low profile
- Rectangular aperture (95mm x 66mm)
- 25mm x 25mm range of motion

Applications

- Coarse positioning of standard or high speed nanopositioners

Piezostage compatibility

The manual Microstage is compatible with the following nanopositioners :

- BIO2 (see pages 14-15)
- LT2 (see pages 16-17)
- LFHS2 (see pages 18-19)
- LTHS2 (see pages 20-21)
- BIO3 (see pages 24-25)
- LT3 (see pages 26-27)
- LFHS3 (see pages 28-29).

Upon request, it can also be manufactured to be compatible with Z-INSERT (see pages 12-13).

Drawing

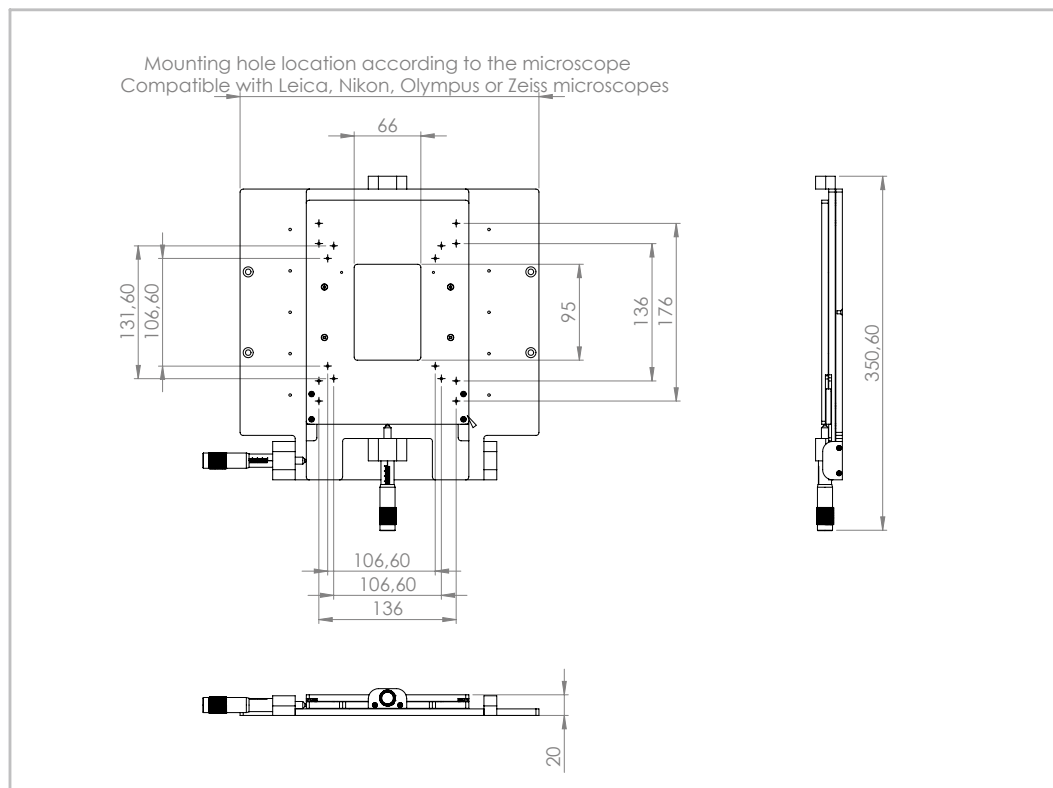

HYBRID SYSTEM

Piezoconcept can provide fully integrated Hybrid positioning Systems for use with inverted optical microscopes (ZEISS, OLYMPUS, NIKON, LEICA). Easy to operate and affordable, our Hybrid Systems combine a manual micrometer driven, two axis, linear motion stage with either standard speed, long range or ultra-high speed ,shorter range nanopositioners. A stable blocking force into each axis of the coarse positioning stage provides a secure base for precision positioning. The nanopositioning system provide sub-nanometer resolution under closed loop control.

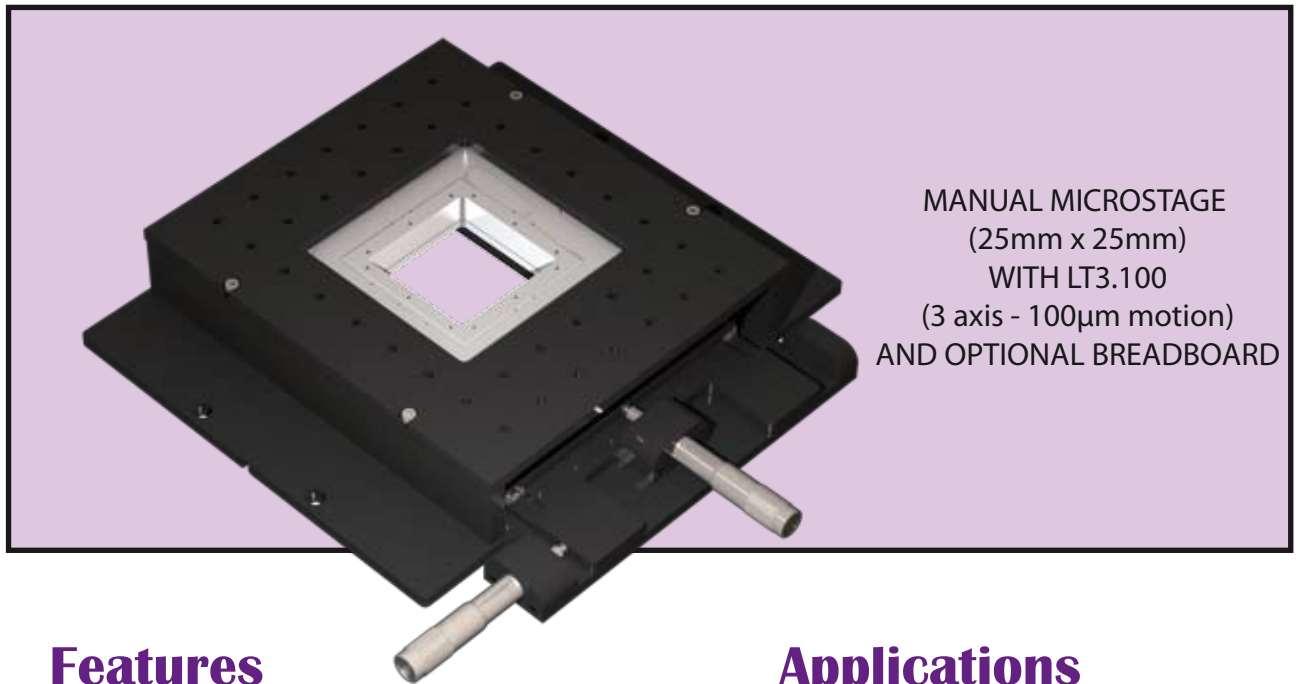

MANUAL MICROSTAGE
(25mm x 25mm)
WITH LT3.100
(3 axis - 100 μ m motion)
AND OPTIONAL BREADBOARD

Features

- Low profile
- 25mm x 25mm coarse positioning
- Standard or Ultra-High speed
- Up to 300 μ m XYZ travel (piezostage)

Applications

- Super Resolution microscopy
- Nanolithography
- Particle tracking
- Confocal microscopy
- Atomic Force Microscopy

Some examples

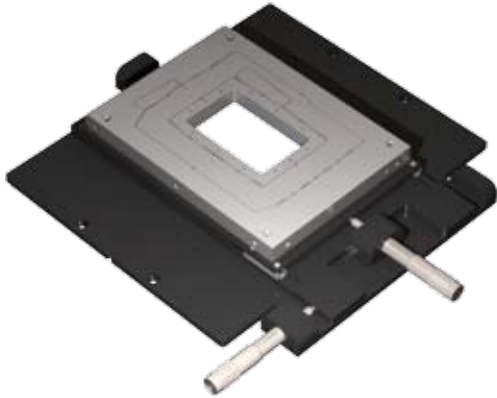

Hybrid System with BIO2

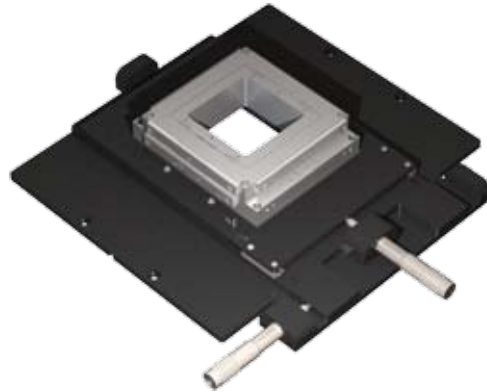

Hybrid System with LFHS3

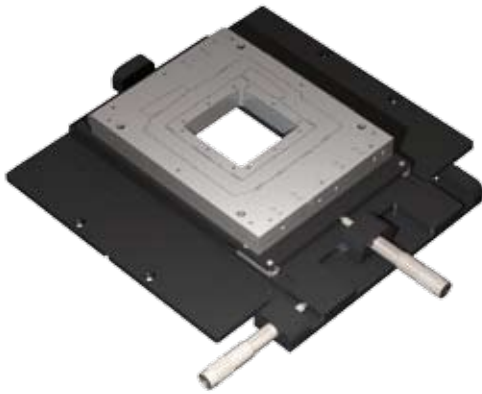

Hybrid System with LT3

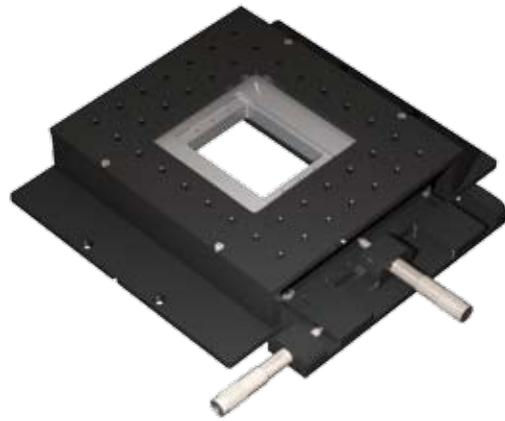

Hybrid System with LTHS2
and optional Breadboard

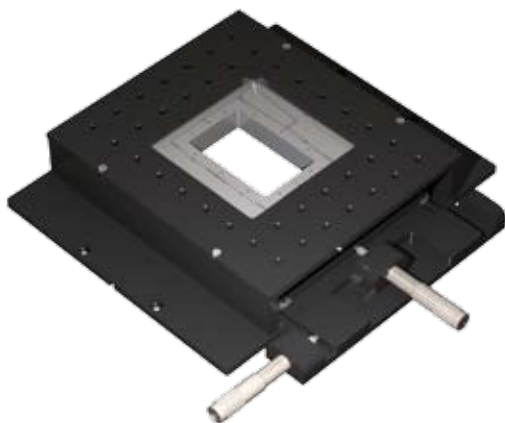

Hybrid System with BIO3
and optional Breadboard

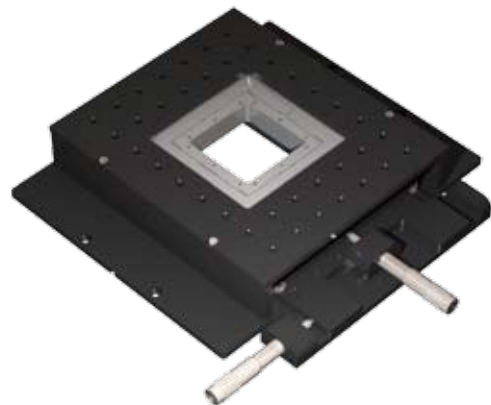

Hybrid System with LT3
and optional Breadboard

ACCESSORIES

Together with the piezostage, we can provide a wide range of accessories such as spacers, extension ring (for the FOC nanopositioner), breadboard, wings but also sample holders.

Sample holders for the BI02/BI03/LTHS2

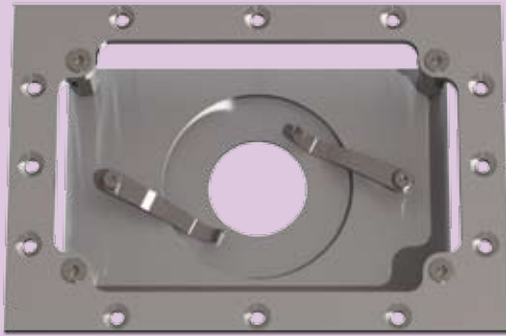

Sample holder
for microscope coverslip

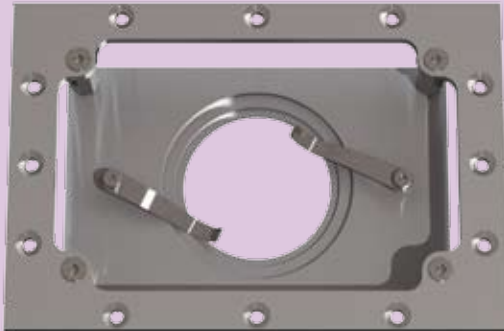

Sample holder
for 35mm Petri dish

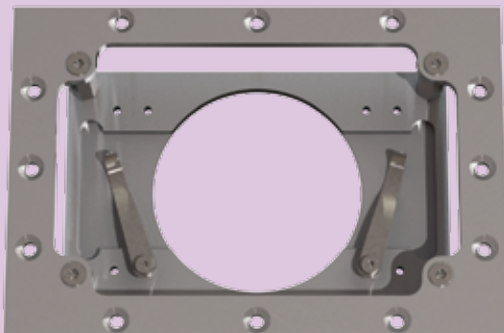

Sample holder
for 75mm long microscope slide

Sample holders for the LT2/LT3/LFHS2/LFHS3

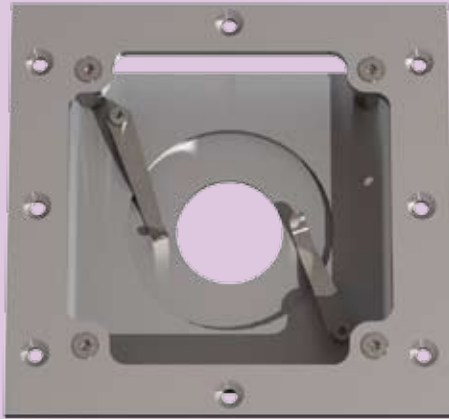

Re-entrant sample holder
for microscope coverslip

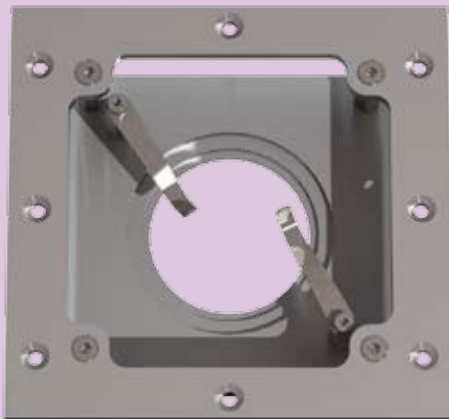

Re-entrant sample holder
for 35mm Petri dish



Top-mounted sample holder
for 75mm long microscope slide
and coverslip adapter

Sample holders for LTHS3/Z-INSERT

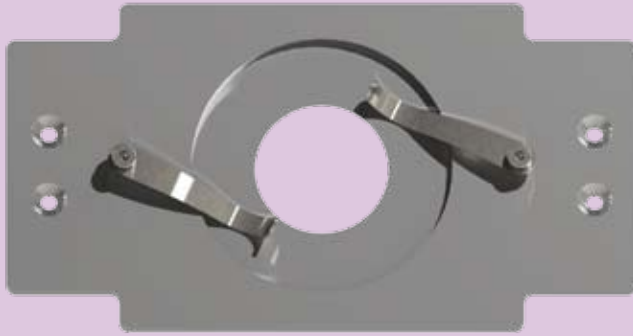

Sample holder
for microscope coverslip



Sample holder
for 35mm Petri dish

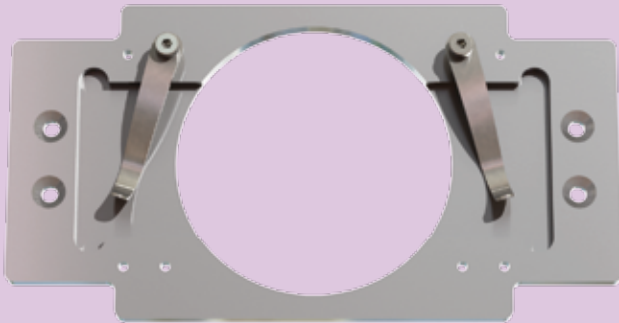

Sample holder
for 75mm long microscope slide

CONTROLLER

The Piezoconcept controller includes ultra low noise and highly linear electronics, closed-loop control (PID) leading to a movement free of positioning errors.

Two different ways are given to the user to control the piezostage :

- an analogue input (BNC) located on the front panel of the controller
- an optional USB interface located on the back panel of the controller



As standard, the analogue input is between 0 and 10V, but it can be changed to -10V/+10V if the stage has to work with National Instrument DAC or eventually Bruker Bioscope/Nanoscope.

Our USB interface is compatible with Labview (VIs are provided) but also with most softwares dedicated to microscopy.



For stage capable of fast movement, a high speed controller is also available. With its 500mA output current, this controller can be used especially for high frequencies applications.

GLOSSARY

Absolute accuracy

Deviation between the actual position and the desired one. If a stage has to move 100 μ m but it moves only 99.99 μ m (measured through an ideal scale), then the inaccuracy is 10nm. The permanent positioning error along an axis is designated as accuracy. Absolute accuracy is affected by calibration errors, linearity errors, hysteresis, Abbe errors and positioning noise.

Backlash

Backlash is a positioning error occurring upon change of direction. Backlash can be caused by insufficiently preloaded thrust or inaccurate meshing of drive components, for example gear teeth. Piezoconcept's flexure motion translation mechanism and piezo actuator designs are inherently backlash free.

Bandwidth

The frequency range to which the amplitude of the stage's motion is dropped by 3dB. It reflects how fast the stage can follow the driving signal.

Drift

A position change over time, which includes the effects of temperature change and other environmental effects. The drift may be introduced from both the mechanical system and electronics.

Friction

Friction is defined as resistance between contacting surfaces during movement. Friction may be constant or speed dependant. Because they use flexure, the nanopositioners from Piezoconcept are friction free.

Hysteresis

The positioning error between forward scan and backward scan. A closed-loop control is an ideal solution for this problem and is done by using a network of High Resolution silicon sensor to provide feedback signals.

Linearity error

The error between the actual position and the first-order best fit line (straight line). Our nanopositioning products are calibrated with laser interferometry and the non linearity errors are compensated down to 0.02% of the full travel.

Orthogonality error

The angular offset of two defined motion axes from being orthogonal to each other. It can be interpreted as a part of crosstalk.

Position noise

The amplitude of the stage shaking when it is on a static command. It is usually measured and specified with Peak-To-Peak value. It is a combination of the sensor noise, driver electronics noise and command noise, etc. The position noise of our stages is very limited due to the very high Signal-To-Noise ratio of the Silicon HR sensors we use.

Range of motion

The maximum displacement of the nanopositioners.

Resolution

The minimum step size the stage can move. It is mainly defined by the DAC resolution.

Resonant frequency

Piezostage are oscillating mechanical systems characterized by a resonant frequency. The resonant frequency that we give is the lowest resonant frequency that can be seen on a nanopositioner. In general, the higher the resonant frequency of a system, the higher the stability and the wider working bandwidth the system will have. The resonant frequency of a piezostage is determined by the square root of the ratio of stiffness and mass.

Silicon HR sensor

Piezoconcept use temperature compensated High-Resolution silicon sensors network for reaching highest long-term stability. This measuring device is capable of measuring position noise in the picometer range and its response is not dependent of the presence of pollutants, air pressure changes like other high-end sensors can be.

Step response time

The step response time is the time needed by the nanopositioner to do the travel from 10% of the commanded value to 90% of the commanded value. The step response time reflects the dynamic characteristics of the system and is relatively independent of the step size.

NOTES

TERMS AND CONDITIONS OF SALE

1. Definition : In this document the following words shall have the following meanings :

"Buyer" means the organisation or person who buys Goods

"Goods" means the articles to be supplied to the Buyer by the Seller;

"Intellectual Property Rights" means all patents, registered and unregistered designs, copyright, trade marks, know-how.

"Seller" means PIEZOCONCEPT, 15 Rue du Bocage, FR-69008 LYON

2. General : These Terms and Conditions shall apply to sales of Goods by the Seller to the Buyer to the exclusion of all other terms and conditions referred to, offered or relied on by the Buyer whether in negotiation or at any stage in the dealings between the parties, including any standard or printed terms tendered by the Buyer, unless the Buyer specifically states in writing, separately from such terms, that it wishes such terms to apply and this has been acknowledged by the Seller in writing. Any variation to these Terms and Conditions (including any special terms and conditions agreed between the parties) shall be inapplicable unless agreed in writing by the Seller.

3. Price and Payment : The price shall be the Recommended Retail Price less agreed discount, unless otherwise agreed in writing between the parties. The price is exclusive of VAT or any other applicable costs. Credit terms may be offered subject to satisfactory credit vetting of the Buyer by the Seller. The offer of credit will be at the sole discretion of the Seller. Where credit is offered payment of the price and any other applicable costs shall be due within 30 days of the date of the invoice supplied by the Seller, unless otherwise agreed in writing. In cases where credit is not offered payment will be required before release of goods by the Seller. The Seller shall be entitled to charge interest on overdue invoices from the date when payment becomes due from day to day until the date of payment at a maximum rate of 10 per cent per annum (but in no event more than the amount permitted by the applicable law). If payment of the price or any part thereof is not made by the due date, the Seller shall be entitled to require payment in advance of delivery in relation to any Goods not previously delivered and to refuse to make delivery of any undelivered Goods without incurring any liability whatever to the Buyer for non-delivery or any delay in delivery;

4. Description : Any description given or applied to the Goods is given by way of identification only and the use of such description shall not constitute a sale by description. For the avoidance of doubt, the Buyer hereby affirms that it does not in any way rely on any description when entering into the contract.

5. Sample : Where a sample of the Goods is shown to and inspected by the Buyer, the parties hereto accept that such a sample is representative in nature and the bulk of the order may differ slightly as a result of the manufacturing process.

6. Delivery : Unless otherwise agreed in writing, delivery of the Goods shall take place at the address specified by the Buyer on, or as close as possible to the date required by the Buyer. The Buyer shall make all arrangements necessary to take delivery of the Goods whenever they are tendered for delivery. If the Seller is unable to deliver the Goods because of actions or circumstances under the control of the Buyer, then the Seller shall be entitled to place the Goods in storage until such times as delivery may be effected and the Buyer shall be liable for any expense associated with such storage. Any damages, shortages, over deliveries and duplicated orders should be reported by registered letter to the Seller within 5 days of signed receipt to enable replacement or refund.

7. Risk : Risk in the Goods shall pass to the Buyer upon receipt of the goods. Where the Buyer chooses to collect the Goods itself, risk will pass when the Goods are entrusted to it or set aside for its collection, whichever happens first.

8. Title : Title in the Goods shall not pass to the Buyer until the Seller has been paid in full for the Goods.

9. Return of unused goods : All goods are sold on a firm sale basis, i.e. the Seller will not take back any goods not required or sold by the Buyer, unless otherwise agreed, in which case the following terms apply. Any returns must be authorised by a representative of the Seller before any credit will be given. Where the Seller agrees to accept the return of goods that are not damaged the Buyer will be responsible for the cost of carriage and will ensure that they are carefully packaged to avoid any damage in transit. The Seller will not be obliged to accept any goods that are damaged in any way. The Seller will only accept returns that appear in the Sellers current Publication List. Credit of amounts due or paid in will only be given for goods that are in saleable condition.

10. Limitation of liability : The Seller shall not be liable for any all loss or damage suffered by the Buyer in excess of the contract price. Nothing contained in these Terms and Conditions shall be construed so as to limit or exclude the liability of the Seller for death or personal injury as a result of the Seller's negligence or that of its employees or agents.

11. Intellectual property rights : All Intellectual Property Rights produced from or arising as a result of the performance of this Agreement shall, so far as not already vested, become the absolute property of the Seller, and the Buyer shall do all that is reasonably necessary to ensure that such rights vest in the Seller by the execution of appropriate instruments or the making of agreements with third parties.

12. Force majeure : The Seller shall not be liable for any delay or failure to perform any of its obligations if the delay or failure results from events or circumstances outside its reasonable control, including but not limited to acts of God, strikes, lock outs, accidents, war, fire, breakdown of plant or machinery or shortage or unavailability of raw materials from a natural source of supply, and the Seller shall be entitled to a reasonable extension of its obligations. If the delay persists for such time as the Seller considers unreasonable, it may, without liability on its part, terminate the contract.

13. Relationship of parties : Nothing contained in these Terms and Conditions shall be construed as establishing or implying any partnership or joint venture between the parties and nothing in these Terms and Conditions shall be deemed to construe either of the parties as the agent of the other.

14. Assignment and subcontracting : The contract between the Buyer and Seller for the sale of Goods shall not be assigned or transferred, nor the performance of any obligation sub-contracted, in either case by the Buyer, without the prior written consent of the Seller.

15. Waiver : The failure by either party to enforce at any time or for any period any one or more of the Terms and Conditions herein shall not be a waiver of them or of the right at any time subsequently to enforce all Terms and Conditions of this Agreement.

16. Governing law and jurisdiction : This Agreement shall be governed by and construed in accordance with the laws of France and the parties hereby submit to the exclusive jurisdiction of the French courts.

The PIEZOCONCEPT Company



PIEZOCONCEPT

Your piezostage creator

www.auniontech.com

Tél : 4006 888 532

Email : info@ahuniontech.com