

VAHEAT

DYNAMIC THERMAL CONTROL

Precise temperature control for high-resolution microscopes.



INTERFERENCE
HIGH RESOLUTION OPTICAL MICROSCOPY



FAST. SMALL. PRECISE.

VAHEAT is a precise temperature control unit for optical microscopes. It combines local heating with direct temperature sensing in the sample volume. This allows for fast and precise temperature adjustment with heating rates up to 100 °C/s. VAHEAT is compatible with all commercial microscopes and objectives.



Highlights

- Fast and precise temperature control
- Highly compact system design
- No excessive heating of optical components
- Fast and simple installation
- No thermal calibration nor characterization necessary

Key Features



Operating temperature range RT-100°C (200°C optional)



Full remote control via USB



Heating rates up to 100 °C/s



Four heating modes (AUTO, DIRECT, SHOCK, PROFILE)



Relative precision of 0.1 °C



Compatible with inverted microscopes, immersion medium

Live Cells

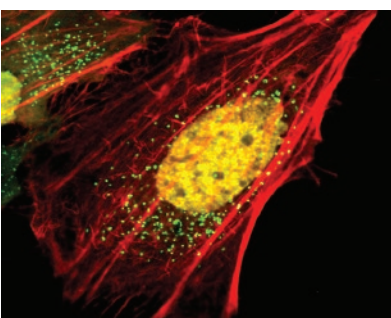

Phase Transitions

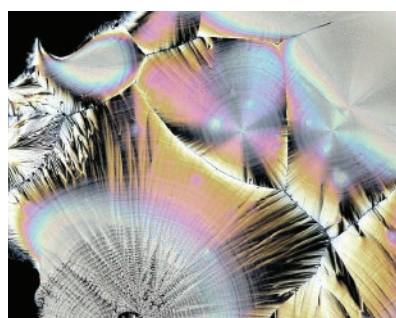

DNA Science



Diffusion



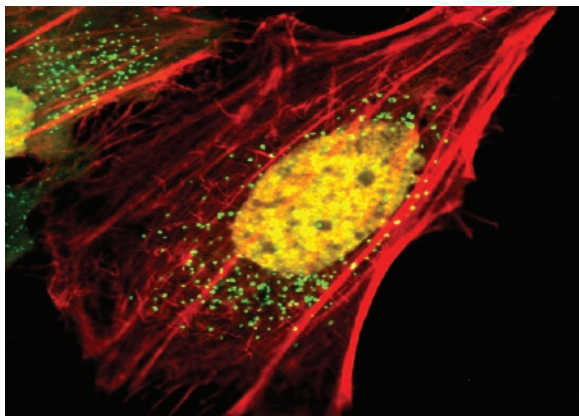

Biology

- Live cell imaging
- Developmental biology
- DNA science



Medicine

- Immunology
- Neuroscience
- Protein folding

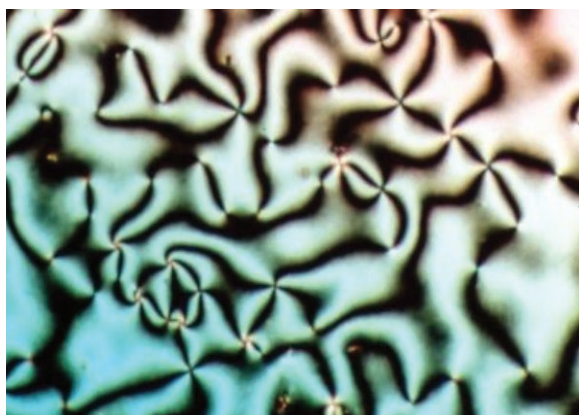

Material Sciences

- Particle diffusion
- Crystallization and nucleation
- Phase transitions



Physics & Industry

- Melting point analysis
- Microfluidics
- Dynamic temperature tuning

Compatible Imaging Techniques

- ✓ Confocal Microscopy
- ✓ Superresolution Microscopy (TIRF, STORM, PALM, PAINT)
- ✓ iSCAT
- ✓ Widefield Imaging
- ✓ Fluorescence Lifetime Imaging (FLIM)
- ✓ Atomic Force Microscopy (AFM)

Smart Substrates

Your sample is directly prepared on our smart substrates that combine a transparent heating element with a highly sensitive temperature probe. The smart substrates have a thickness of 170 μm , are made for live cell imaging and are compatible with most of the commercially available microscope objectives optimized for #1.5H thickness cover slips.

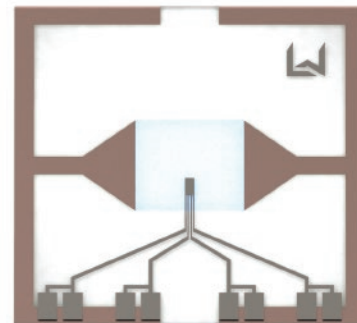

Microscope Adapter

The microscope adapter is the connecting part between the Smart Substrate and the control unit. Its footprint is similar to a standard microscope slide (25x75 mm²). It can even be combined with white light condenser illumination from above due to its slim design.

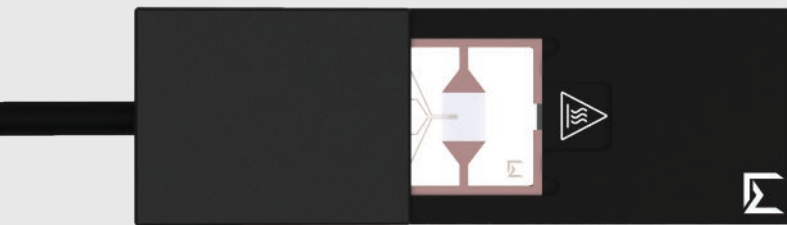

Control Unit

The control unit is the interface between you and your sample temperature. It continuously displays the current temperature and allows to easily adjust the setpoint by turning a single knob. A USB interface enables remote control and synchronization of the system parameters with your image acquisition system.



Desktop Application

Our graphical user interface (GUI) allows you to easily track the thermal history and to define arbitrary temperature protocols. Simply start a measurement and monitor your temperature remotely.

Fast Temperature Response

The feedback driven heating element directly integrated into the smart substrate enables extremely fast temperature variations with up to 100 °C/s providing unprecedented temperature stability over short and long time scales.

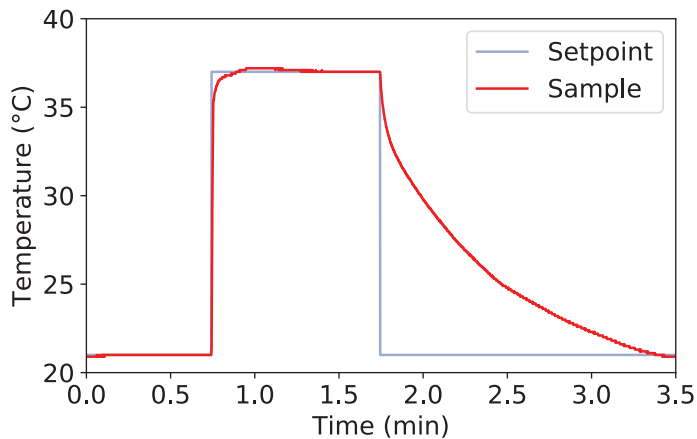

Temperature response of a Smart Substrate attached to a thermal load of 200 µl water.

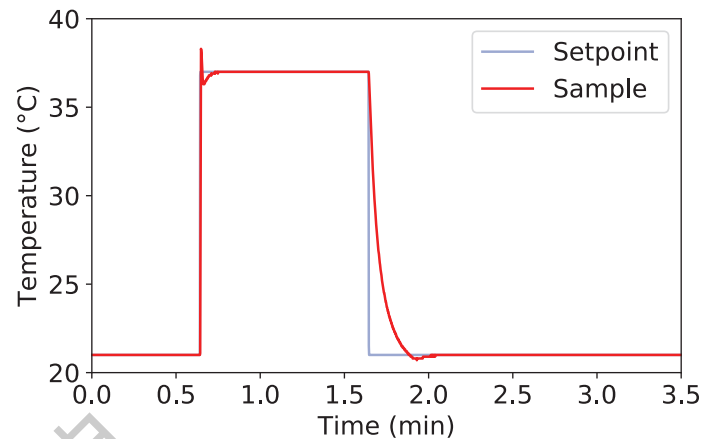

Temperature response a Smart Substrate without additional heat load.

Excellent Image Quality

The Point-Spread-Function (PSF) represents the image of a point-like object acquired with a microscope. Its geometry is a direct measure for the image quality.

- No image alteration for air objectives for temperatures ranging from 20 °C to 100 °C
- No change in image quality for immersion and air objectives in lateral direction within a temperature range between 20°C and 80°C
- Minimal axial PSF size increase (30%) for immersion objectives for temperatures between 20°C and 80 °C related to intrinsic material properties

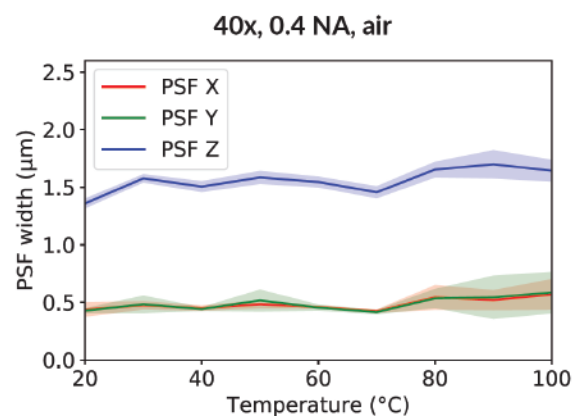
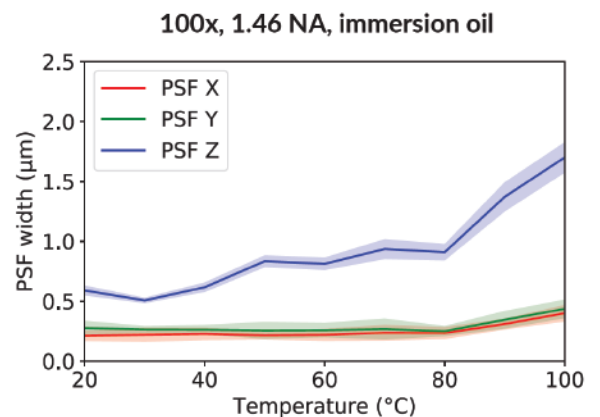

Temperature Profiles

User defined temperature protocols allow for precise manipulation of cellular organisms. The example shows fluorescence imaging of tubulin (SIR-tubulin) of normal human dermal Fibroblast (NHDF) cells under physiological conditions at 37 °C and after two heat shocks applied for 30 s at 45 °C and 55 °C while maintaining the sample otherwise at 37 °C.

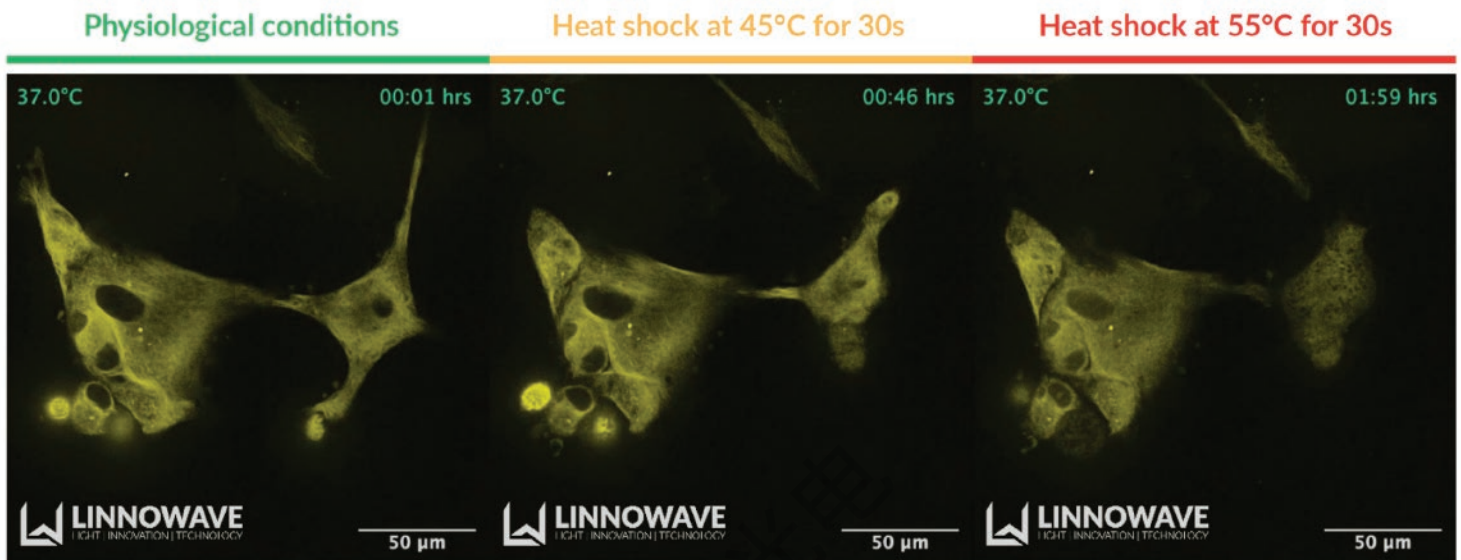

VAHEAT - 4 Heating Modes

AUTO

Feedback controlled temperature stabilization of your sample volume. Simply set the desired temperature and let VAHEAT do the rest.

DIRECT

Directly control the heating power while tracking your sample temperature. This measurement scheme is compatible with e.g. AFM measurements.

SHOCK

Exploit the extremely fast heating dynamics of VAHEAT using this mode.

PROFILE

Define your individual temperature profile to steer e.g. a chemical reaction and let VAHEAT control the sample temperature any way you like.

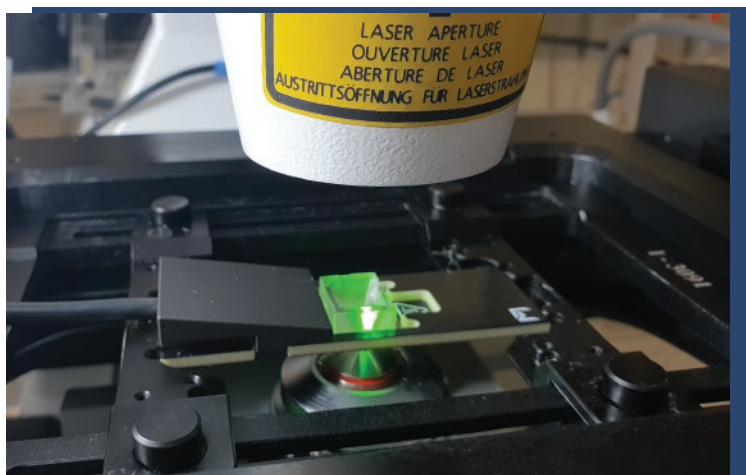

VAHEAT - Compatibility

VAHEAT can be easily mounted on an inverted or upright microscope due to the standardized size of its microscope adapter with a footprint of a microscope slide.

Technical Specifications



Specifications VAHEAT

Version	Standard Range	Extended Range
Technical Specifications		
Max. Heating Power	< 2.5 W	< 5.0 W
Sample Temperature	RT - 105 °C	RT - 250 °C
Relative Temperature Precision	+/- 0.1 °C	
Operating Modes	Remote, Auto, Direct, Shock, Profile	
General and Environmental Specifications		
Qualifications	CE, FCC, RoHS compliant	
DC Input	24 V DC, < 0.75 A	
Power Consumption	< 10 W	< 18 W
Remote Control	JSON via USB	
Operating Temperature Range	15 - 40 °C	
Storage Temperature Range	-10 - 60 °C	
Operating Relative Humidity	non condensing, < 90%	
Dimensions Control Unit	125 x 65 x 125 mm ³ (W X H X D)	
Dimensions Microscope Adapter	75 x 2.5 x 25 mm ³ (W X H X D)	
Dimensions Smart Substrate	18 x 0.17 x 18 mm ³	18 x 0.5 x 18 mm ³

Dimensions

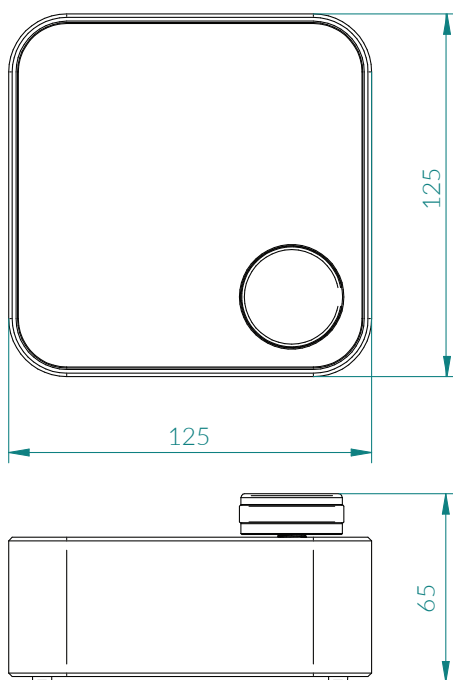

Control Unit

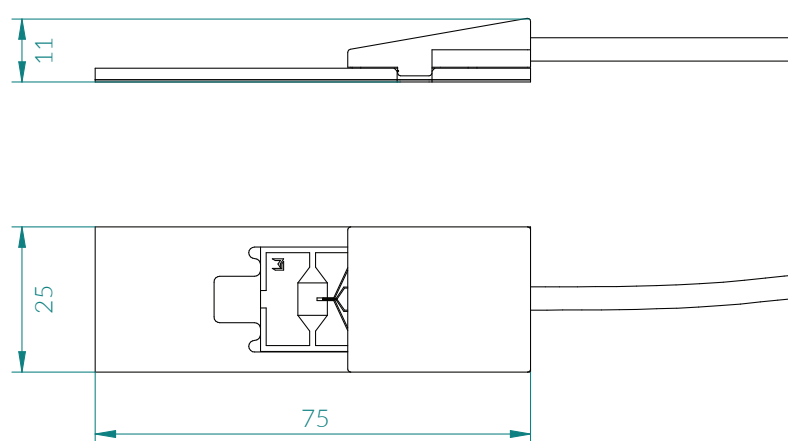

Universal Microscope Adapter