

cronologic

Ndigo5G-8
Ndigo5G-10

User Guide

Revision 1.2.1 as of 2020-09-20
Firmware 2 (build 4865), Driver v1.4.3

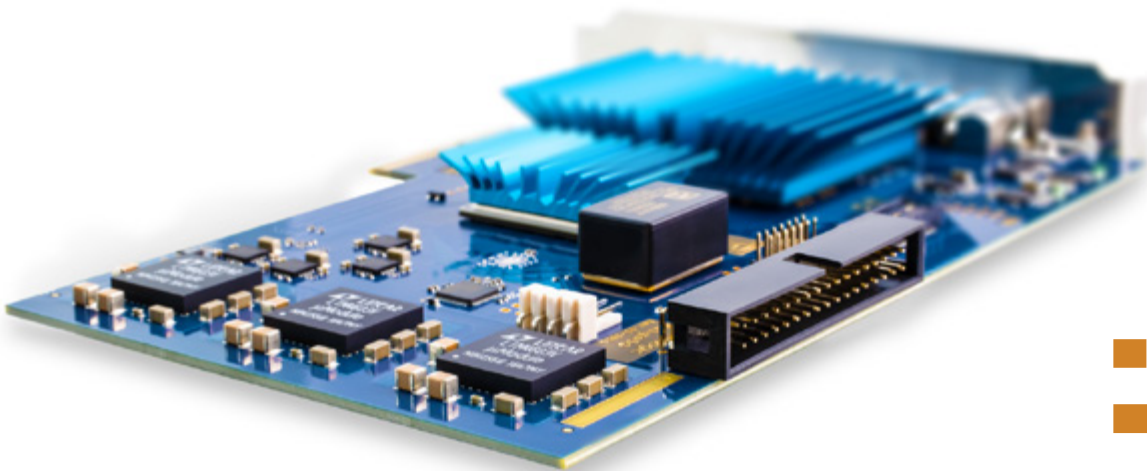

Ndigo5G

Table of Contents

1 Introduction	4
1.1 Features	4
2 Hardware	5
2.1 Installing the Board	5
2.1 Ndigo5G External Inputs and Connectors	6
2.2.1 Connectors	6
2.2.2 Analog Inputs	7
2.2.3 Digital Inputs	8
2.3 Extension Card	9
2.1 Ndigo5G Functionality	10
2.4.1 ADC Modes	10
2.4.2 Zero Suppression	12
2.4.3 Trigger Blocks	12
2.4.4 Gating Blocks	17
2.4.5 Auto Triggering Function Generator	20
2.4.6 Timestamp Channel	20
2.4.7 Data Lookup Table	21
2.5 Multiple Ndigo boards synchronization	21
2.5.1 Calibration Procedure	22
2.5.2 Synchronizing a Ndigo5G and an HPTDC8-PCI	24
2.6 Performing a firmware update	24
2.7 Calibrating the TDC	25
3 Driver Programming API	27
3.1 Constants	27
3.2 Initialization	27
3.2.1 Structure ndigo_init_parameters	27
3.3 Status Information	29
3.3.1 Functions for Information Retrieval.	29
3.3.2 Structure ndigo_static_info	29
3.3.3 Structure ndigo_param_info	31
3.3.4 Structure ndigo_fast_info	32
3.3.5 Structure ndigo_slow_info	32
3.4 Configuration	33
3.4.1 Structure ndigo_configuration	33
3.4.2 Structure ndigo_trigger	36
3.4.3 Structure ndigo_trigger_block	36
3.4.4 Structure ndigo_gating_block	38
3.4.5 Structure ndigo_extension_block	39
3.4.6 Run Time Control.	39
3.5 Readout	39
3.5.1 Input Structure ndigo_read_in	39
3.5.2 Input Structure ndigo_read_out	40
3.6 Other Functions	40
3.6.1 LED control	40

4 Packet Format	41
4.0.1 Output Structure ndigo_packet.	41
5 C-Example	43
6 Technical Data	45
6.1 Digitizer Characteristics	45
6.1.1 1-Channel-Mode (5Gsp/s)	45
6.1.2 2-Channel-Mode (2.5 Gsp/s).	46
6.1.3 4-Channel-Mode (1.25 Gsp/s).	46
6.2 Electrical Characteristics	46
6.2.1 Oscillator	46
6.2.2 Environmental Conditions for Operation	47
6.2.3 Environmental Conditions for Storage	47
6.2.4 Power Supply	47
6.2.5 Analog Inputs.	47
6.3 Information Required by DIN EN 61010-1	48
6.3.1 Manufacturer	48
6.3.2 Intended Use and System Integration	48
6.3.3 Cooling	48
6.3.4 Environmental Conditions	49
6.3.5 Inputs	49
6.3.6 Recycling	47
7 Revision History	50
7.1 Firmware	50
7.2 Driver & Applications	50
7.3 User Guide.	50

Introduction

The **Ndigo5G** is a digitizer and transient recorder designed to sample relatively short pulses in rapid repetition. It produces a stream of output packets, each containing data from a single trigger event together with a timestamp.

By default the **Ndigo5G** is equipped with a passive cooling system (see [document title](#)). If necessary, the unit might be ordered with an active cooling system on demand (see [Figure 1.1](#)).

1.1 Features

- **10 bit** dynamic range for comprehensive measurements and minimized quantization noise
- up to **5 Gsps** sample rate (in 1 channel mode) for increased resolution in time domain
- up to **4 channels** available for your individual measurement setups
- digital input with TDC that also can be used for gating and triggering
- 2nd digital input for gating or triggering
- PCIe 4x 1.1 with **800 MB/s throughput** for simple and fast data transfer to most PCs.
- multiple boards can be synchronized via reference clock if more channels are required
- extension board available with 4 additional digital inputs.



Figure 1.1: Ndigo5G equipped with active cooling system.

2.0 Hardware

2.1 Installing the Board

The **Ndigo5G board** can be installed in any x4 (or higher amount of lanes) PCIe slot. If the slot electrically supports less than 4 lanes, the board will operate at lower data throughput rates.

Please ensure proper cooling of the device. The **Ndigo5G** has an onboard temperature detection. If the ADC chip temperature exceeds 90C a warning is issued to the device driver. In case the temperature is higher than 95C the ADC is disabled to avoid damage. Using a PCI-slot cooler is in many cases an appropriate solution to circumvent problems caused by overheating if the board is used inside a PC. The Ndigo-Crate will provide sufficient cooling under normal operating conditions.

Using a single **Ndigo5G**, no further connections need to be made.

For applications that require more than 4 ADC channels, several Ndigo boards can be operated in sync. Any board of the **Ndigo product line** can be synced to other Ndigo boards, allowing, for instance, for a combination of high speed ADCs (**Ndigo5G**) and slower high resolution ADCs (**Ndigo250M-14**).

The signals used for board synchronization and inter-board triggering are transferred on a bus between the boards. Join all C2 connectors (see [Figure 2.3](#) on page 7) on the boards using a ribbon cable. Both ends of the bus need to be terminated properly. If using a **Ndigo Crate** PCIe expansion enclosure, connectors providing the termination are located on the crate mainboard next to the PCIe slots to the extreme left and right. For more details, please refer to the Ndigo Crate user guide. In applications that use only a few Ndigo boards installed directly inside a PC, termination PCBs available from cronologic can be used.

Ndigo5G's standard device driver can be used to read out all boards and acquire data. For more complex scenarios, using the cronoSync-library, which is part of cronoTools, is recommended. The cronoSync library is provided with the Ndigo device driver. Please refer to the cronoTools user guide for more information.

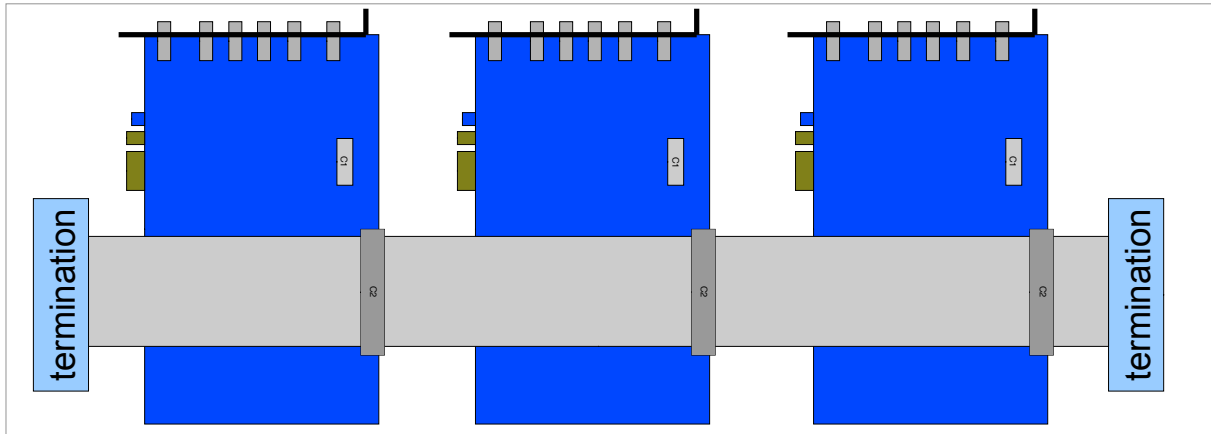

Figure 2.1: If several Ndigo boards are connected to work in sync, the boards must be connected using a ribbon cable as bus for synchronization and trigger signals. Proper termination is required at both ends of the cable.

2.2 Ndigo5G External Inputs and Connectors

2.2.1 Connectors

The inputs of the **Ndigo5G** are located on the PCI bracket. [Figure 2.3](#) on page 7 shows the location of the 4 analog inputs A to D and the two digital inputs G (GATE) and T (Trigger). Furthermore, two board interconnection connectors can be found at the top edge of the **Ndigo5G**, as displayed in [Figure 2.3](#) on page 7. Connector C1 is used for a board-to-board connection (e.g. to link a HPTDC8-PCI and a **Ndigo5G** via a **Ndigo Extension board**, see [chapter 2.3](#)). Connector C2 is used as a bus interface between multiple Ndigo boards distributing clock, trigger and sync signals. Proper termination must be placed at both ends of the bus interconnection ribbon cable.

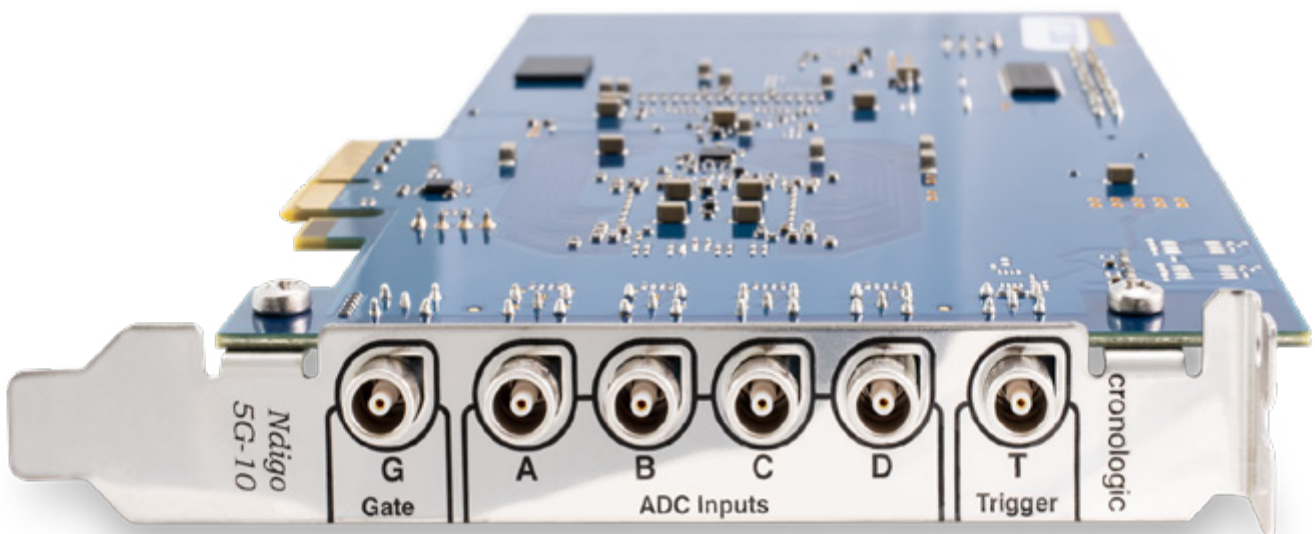

Figure 2.2: Input connectors of an Ndigo5G located on the PCI bracket.

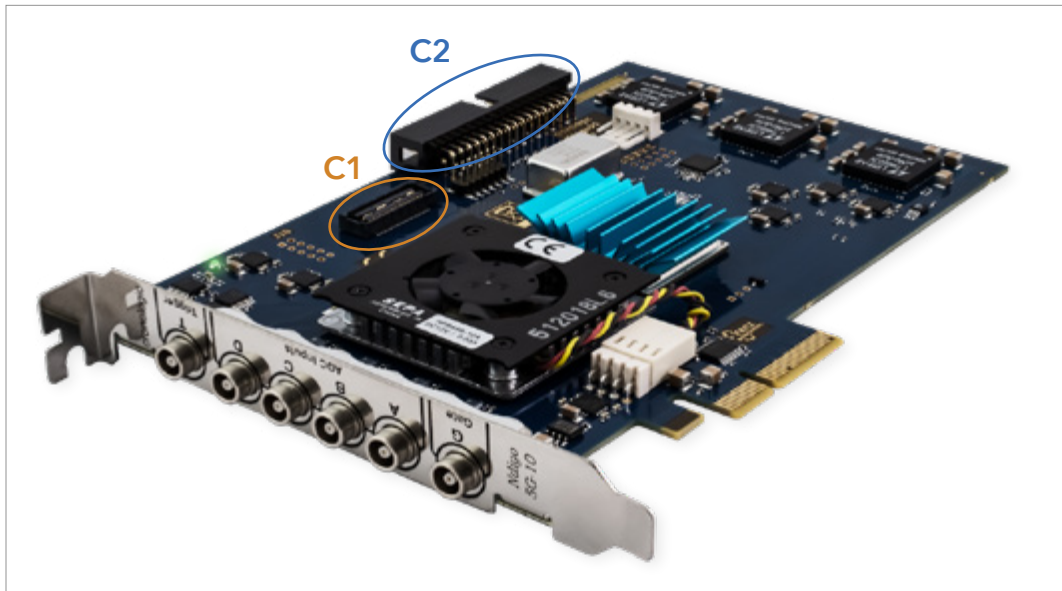

Figure 2.3: Ndigo5G board showing inter-board connectors C1 and C2.

2.2.2 Analog Inputs

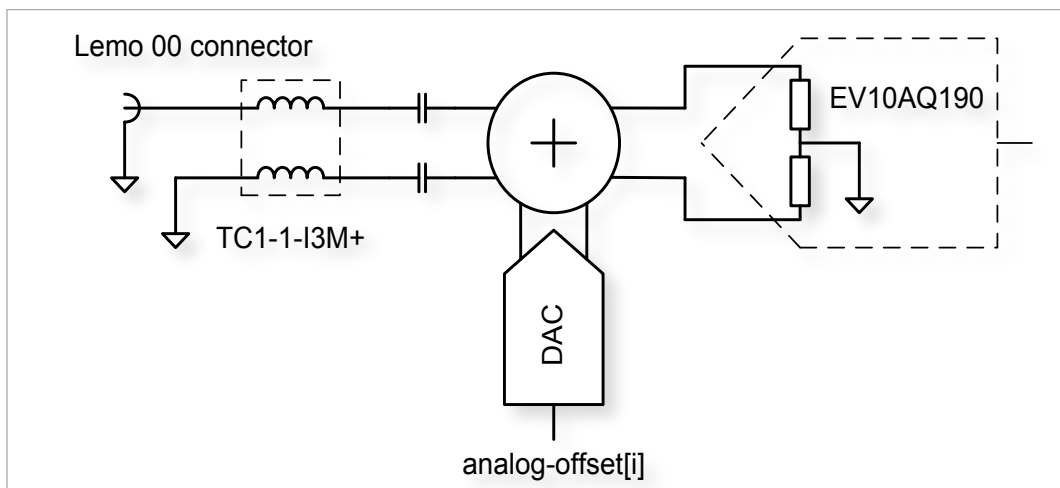

Figure 2.4: Input circuit for each of the four analog channels.

The analog inputs of the ADC are single ended LEMO00 coax connectors. The inputs have a 50Ω impedance and are AC coupled. The inputs are converted to a differential signal using a balun.

Analog Offsets

AC coupling removes the common mode voltage from the input signal. Users can move the common mode voltage to a value of their choice using the analog offset parameter of each channel before sampling.

This feature is useful for highly asymmetric signals, such as pulses from TOF spectrometers or LIDAR systems. Without analog offset compensation, the pulses would begin in the middle of the ADC range, effectively cutting the dynamic range in half (see [Figure 2.6](#)). By shifting the DC baseline to one end of the ADC range, the input range can be used fully, providing the maximum dynamic range. The analog offset can be set between $\pm 0,25V$.

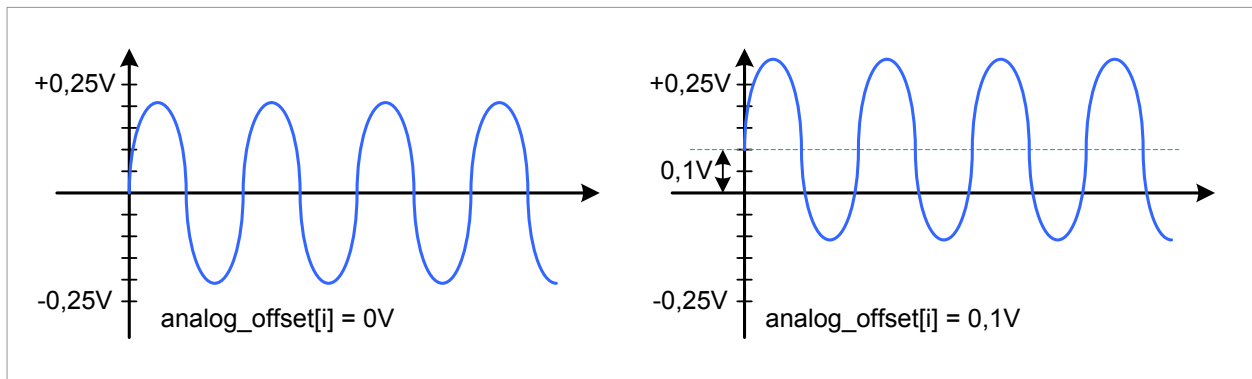

Figure 2.5: Users can add analog offset to the input before sampling

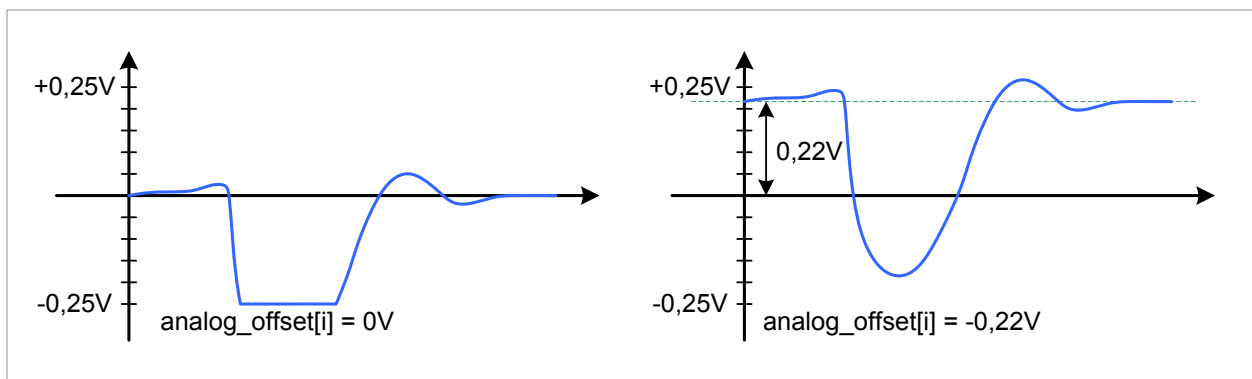

Figure 2.6: Asymmetric signal shifted to increase dynamic range

2.2.3 Digital Inputs

There are two digital inputs on the front slot cover called Trigger and GATE.

Both inputs provide a digital input signal routed to the trigger matrix. These signals can be used to trigger any of the trigger state machines and gating blocks. The inputs are AC coupled. DC offset is configurable via the **dc_offset_parameter** in the **configurations structure** to support positive and negative input pulses.

The configuration is set via the structures **trigger[8]** and **trigger[9]** in the **configuration structure**. The input circuit is shown in [Figure 2.17](#) on page 15.

TDC on Trigger Input

There is a TDC connected to the Trigger input. When used with the TDC, the Trigger input supports negative pulses only. The TDC creates packets of **type 8**. These packets first contain a coarse timestamp and a payload that can be used to calculate the trigger position with higher precision. The function **ndigo_process_tdc_packet()** can be used to replace the coarse timestamp with the precise timestamp. This function is described in [section 3.5](#) on page 40. TDC pulses must have a minimum duration of 3.3ns. The dead-time of the TDC is 32ns.

2.3 Extension Card

The Ndigo Extension card provides additional inputs or outputs to the FPGA. It is connected to the C1 (Samtec QSS-025) connector on an **Ndigo5G** by an Samtec SQCD cable assembly.

The **Ndigo Extension Card** provides up to ten single ended LEMO00 connectors. The circuit connecting to each of these circuits can be chosen to provide inputs or outputs. These can be AC or DC coupled. AC coupled inputs support NIM signaling.

The signals connect to 2.5V IO Pins of the Xilinx Virtex-5 FPGA. The current firmware revision provides the following signal connections:

Connector	QSS Pin	FPGA Pin	Direction	Signal
LEMO00: CH0	22	AD9	Input	Ndigo Extension digital channel 0
LEMO00: CH1			Input	Ndigo Extension digital channel 1
LEMO00: CH2				not connected
LEMO00: CH3			Output	39 MHz clock for HPTDC
LEMO00: CH4			Output	39 MHz clock for HPTDC
LEMO00: CH5			Output	39 MHz clock for HPTDC
LEMO00: CH6			Output	39 MHz clock for HPTDC
LEMO00: CH7				not connected
LEMO00: CH8			Input	Ndigo Extension digital channel 2
LEMO00: CH9			Input	Ndigo Extension digital channel 3
SYNC1: Sync-TDC8				not connected
SYNC1: Sync-HPTDC			Output	Sync for HPTDC

The 4 digital inputs are routed to the bus inputs of the trigger matrix to be used for triggering. The routing can be configured to either ORing the sync bus and extension channels or use the extension channels exclusively.

Connector	Extension Card Digital Channel	Trigger matrix input ignore cable = 1	Trigger matrix input ignore cable = 1
LEMO00: CH0	0	BUS0 = EXT0 Sync Cable 0	BUS0 = EXT0
LEMO00: CH1	1	BUS0 = EXT1 Sync Cable 1	BUS1 = EXT1
LEMO00: CH8	2	BUS0 = EXT2 Sync Cable 2	BUS2 = EXT2
LEMO00: CH9	3	BUS0 = EXT3 Sync Cable 3	BUS3 = EXT3

2.4 Ndigo5G Functionality

2.4.1 ADC Modes

Depending on board configuration, the analog input signal is quantized to 8 or 10 bits. However, the board always scales and offsets the data to 16 bit signed data centered around 0.

Data processing such as trigger detection or packet building are always performed on **3.2ns** intervals. Depending on the ADC mode, this interval may contain 4, 8 or 16 samples.

The board supports using one, two or four channels:

1 Channel Modes A, B, C and D

In these modes, only a single channel is used. The analog signal on that channel is digitized at **5Gsp/s**. Packet size is always a multiple of 16 samples per **3.2ns**. See [Figure 2.9](#) on page 11 and [Figure 2.15](#) on page 15.

2 Channel Modes AC, BC, AD and BD

In these modes, two channels are used simultaneously. The analog signals on these channels are digitized at **2.5Gsp/s** each. Packet size is always a multiple of 8 samples per **3.2ns**. See [Figure 2.8](#) on page 11 and [Figure 2.14](#) on page 14.

4 Channel Mode ABCD

In this mode, all four channels are digitized independently at **1.25Gsp/s** each. The packet size is always a multiple of 4 samples per **3.2ns**. See [Figure 2.7](#) on page 11 and [Figure 2.13](#) on page 14.

Multiple Sampling Modes AAAA, BBBB, CCCC and DDDD

In these modes, only one analog input channel is used, but the channel is sampled independently and simultaneously by four ADCs at **1.25Gsp/s**. The board creates four independent streams with 4 samples each per **3.2ns**.

Using the same trigger setting on all ADCs, can be used to reduce noise by averaging the four channels. To deal with complex triggering conditions, different trigger settings on each of the ADCs can be used.

The **Ndigo5G** provides 4 ADCs sampling at **1.25Gsp/s** each. Higher speed modes are implemented by interleaving two or four of these ADCs.

During interleaving, the **Ndigo5G** firmware reorders and groups the data into a linear sample stream. The process is fully transparent. For users, the only difference is that a **3.2ns** cycle can contain 4, 8 or 16 samples, depending on mode.

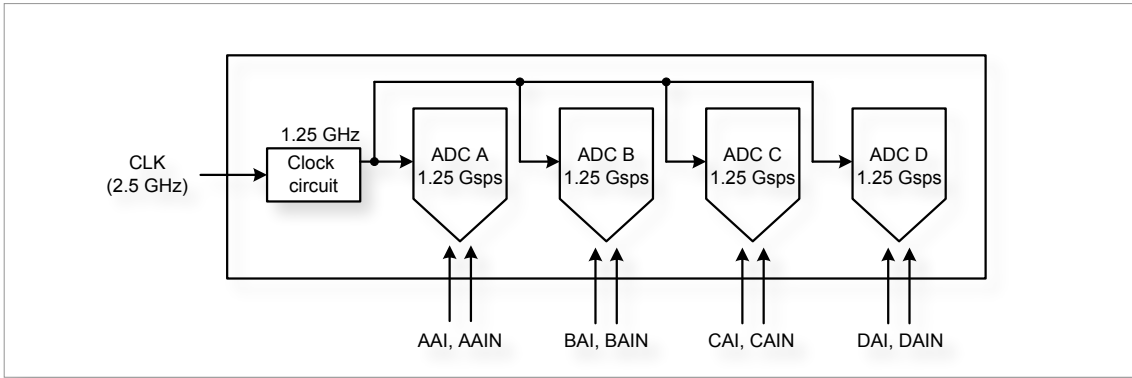

Figure 2.7: ADCs in 4 channel mode ABCD at 1.25Gps.

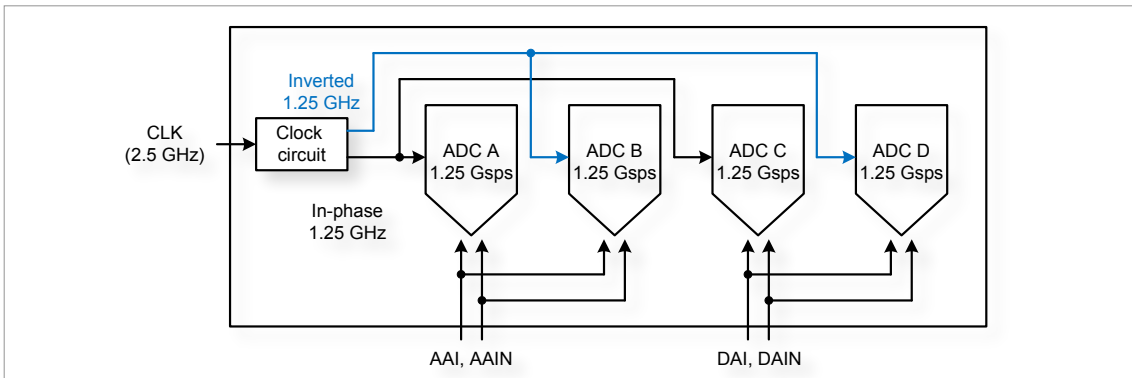

Figure 2.8: ADCs in 2 channel mode AD, interleaved for 2.5Gps.

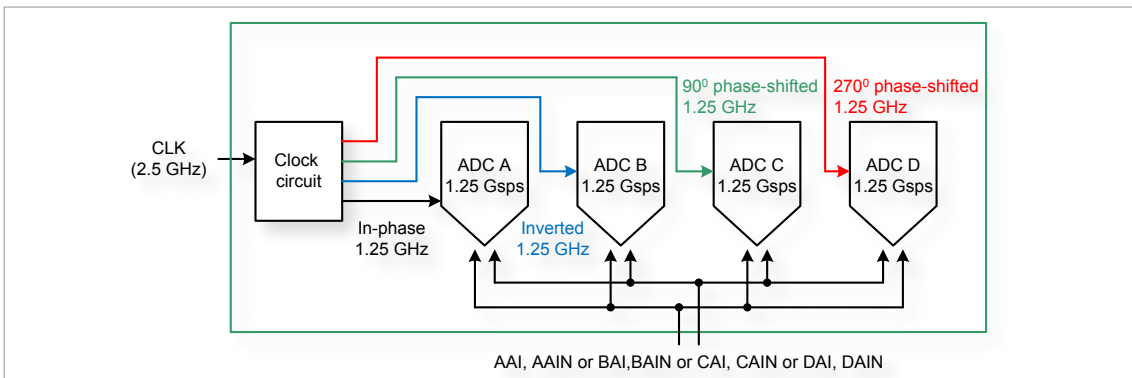

Figure 2.9: ADCs in 1 channel mode A, B, C or D interleaved for 5Gps.

2.4.2 Zero Suppression

One of **Ndigo5G**'s key features is on-board zero suppression to reduce PCIe bus load. Only data that passes specifications predefined by the user is transmitted. This guide refers to transmitted waveform data as "packets". A packet contains the waveform data and a timestamp giving the absolute time (i.e. the time since start of data acquisition) of the packet's last sample.

[Figure 2.10](#) shows a simple example: Data is written to the PC only if values exceed a specified threshold. Expanding on that, **Ndigo5G**'s zero suppression can be used to realize much more complex scenarios.

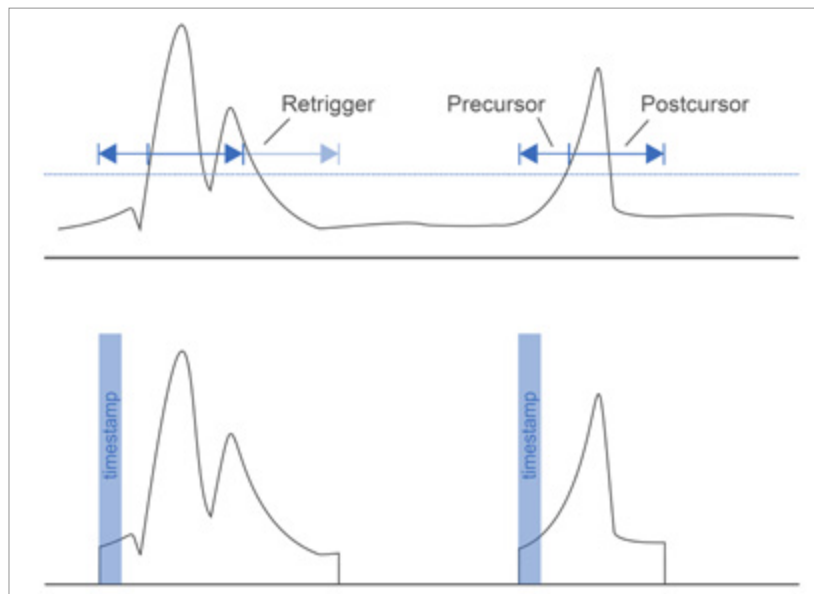

Figure 2.10: Simple zero suppression: Only data with values above a threshold are written to the PC.

2.4.3 Trigger Blocks

Ndigo5G-10 and **Ndigo5G-8** record analog waveforms using zero suppression. Whenever a relevant waveform is detected, data is written to an internal FIFO memory. Each ADC channel has one trigger block determining whether data is written to the FIFO. The parameters are set in structure **ndigo_trigger_block** (See [chapter 3.4.3](#) on page 36).

Each trigger block consists of two independent units that check the incoming raw data stream for trigger conditions ([Fig. 2.10](#) on page 12). Users can specify a threshold and can choose whether triggering is used whenever incoming data is below or above the threshold (level triggering) or only if data exceeds the threshold (edge triggering).

A gate length can be set to extend the trigger window by multiples of **3.2ns**. Furthermore, if users choose precursor values > 0 , the trigger unit will start writing data to the FIFO precursor $3:2ns$ before the trigger event.

When using edge triggering, all packets have the same length ([Figure 2.11](#) on page 13): precursor + length + 1 cycles of **3.2ns**. For level triggering, packet length is data dependent ([Figure 2.12](#) on page 14).

Please note that triggering is not accurate to sample. For each **3.2ns** clock cycle, it is determined whether on any sample during that clock cycle a trigger condition is met. The clock cycle is then selected as the trigger point. As a result, the trigger sample can be anywhere within a range of up to 16 samples in single channel mode ([Figure 2.15](#) on page 15) at 16 samples per **3.2ns**.

If retriggering is active, the current trigger window is extended when a trigger event is detected inside the window.

A trigger block can use several input sources:

- the 8 trigger decision units of all four ADC channels ([Figure 2.16](#) on page 15)
- the GATE input ([Figure 2.17](#) on page 15)
- the Trigger input ([Figure 2.17](#) on page 15)
- a function trigger providing random or periodic triggering ([Section 2.4.5](#) on page 20)
- triggers originating from other cards connected with the sync cable or from the Ndigo Extension card (BUS0, BUS1, BUS2, BUS3)
- A second set of trigger units for the digital inputs Trigger, GATE, BUS0, BUS1, BUS2, and BUS3 that is set in hardware to positive edge triggering. This set of triggers is not available as inputs for the gate blocks.

Trigger inputs from the above sources can be concatenated using logical "OR" ([Figure 2.19](#) on page 16) by setting the appropriate bits in the trigger blocks source mask.

Triggers can be fed into the gate blocks described on page 14 ([Figure 2.20](#)). Gate blocks can be used to block writing data to the FIFO. That way, only zero suppressed data occurring when the selected gate is active is transmitted. This procedure reduces PCIe bus load even further ([Figure 2.20](#)).

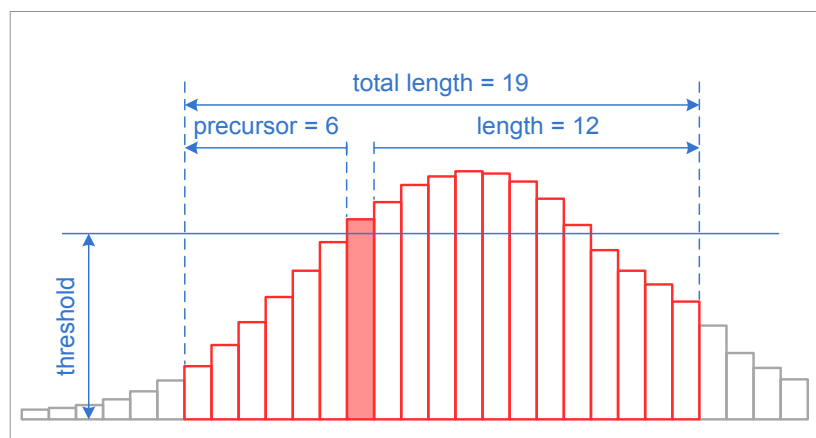

Figure 2.11: Parameters for edge triggering

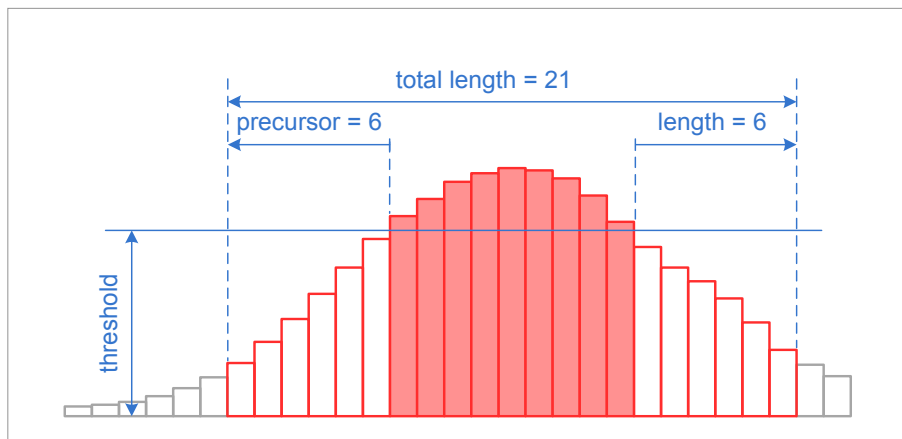

Figure 2.12: Parameters for level triggering

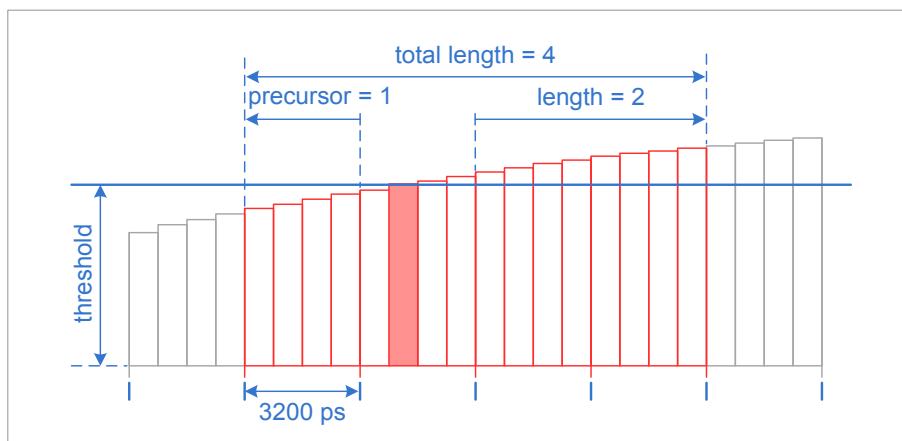

Figure 2.13: Triggering in 4 channel mode at 4 samples per clock cycle.

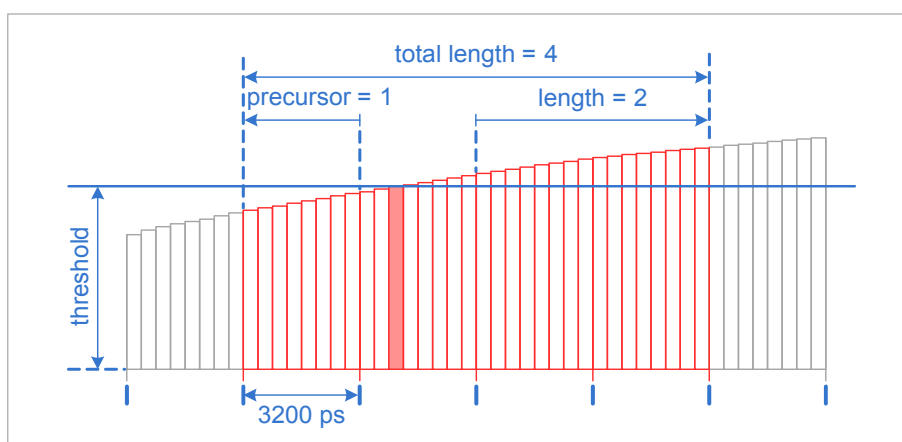

Figure 2.14: Triggering in 2 channel mode at 8 samples per clock cycle.

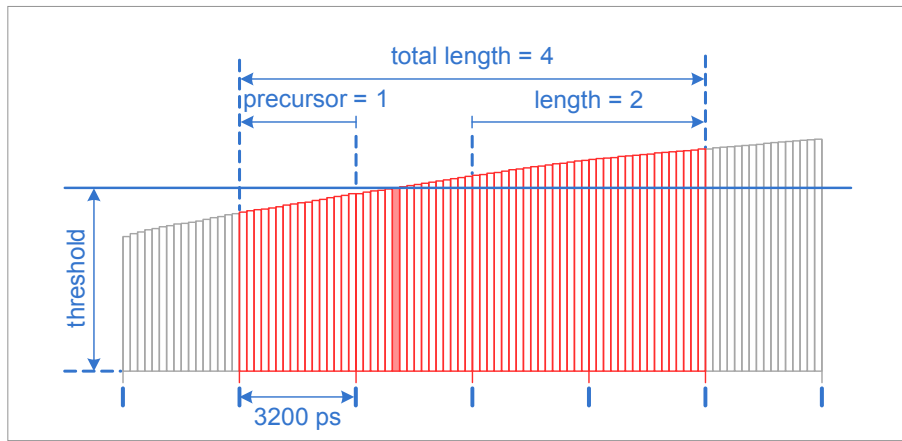

Figure 2.15: Triggering in 1 channel mode at 16 samples per clock cycle.

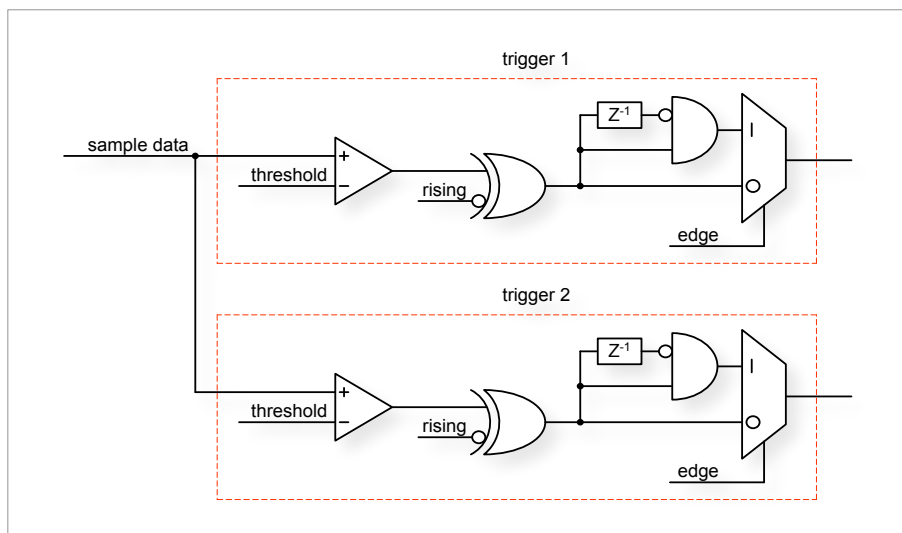

Figure 2.16: From the ADC inputs, a trigger unit creates an input flag for the trigger matrix. Each digitizer channel (A, B, C, D) has two trigger units.

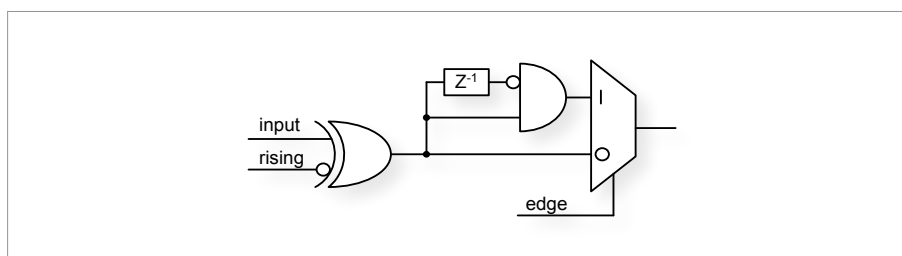

Figure 2.17: The digital inputs Trigger, GATE, BUS0, BUS1, BUS2 and BUS3 have simpler trigger units.

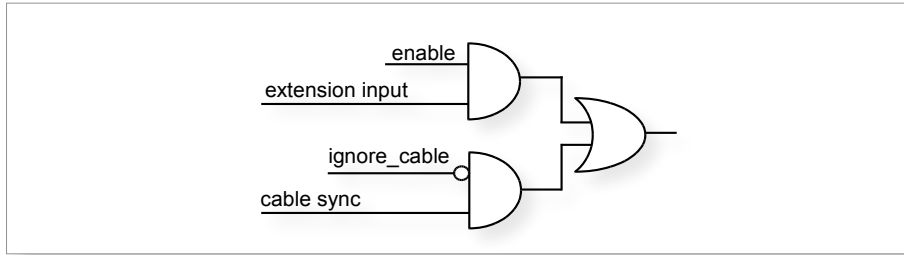

Figure 2.18: The extension block combines signals from the optional extension board and the sync cable.

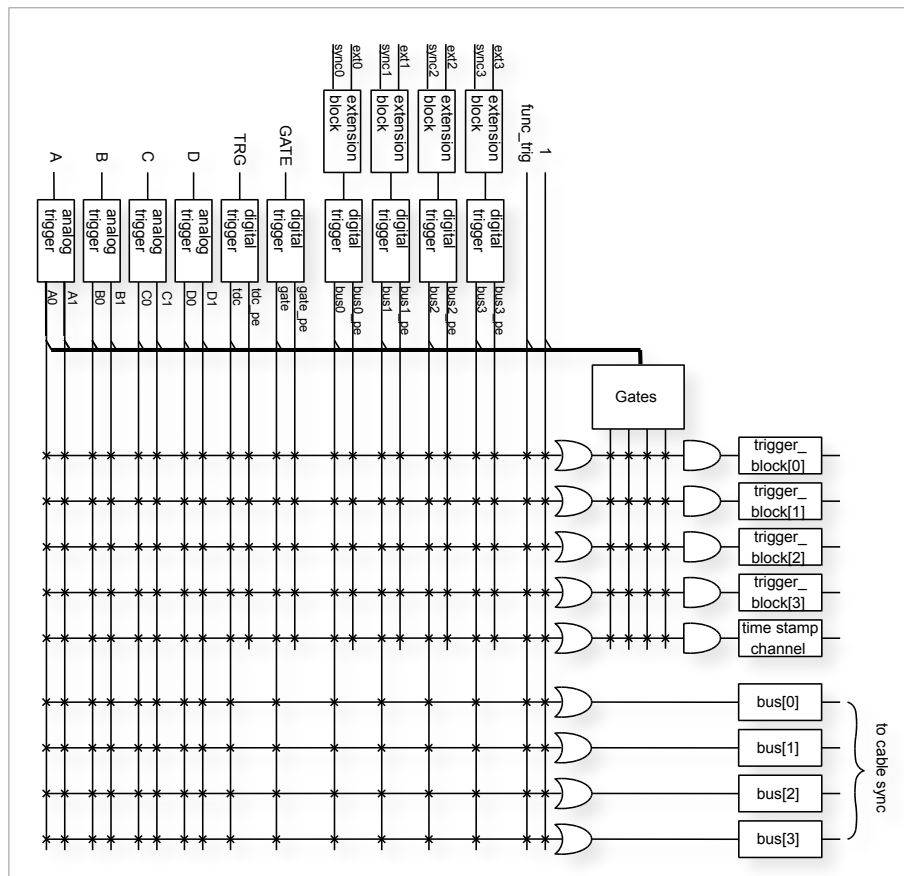

Figure 2.19: Trigger Matrix: The trigger signals of each ADC channel, the trigger input, the GATE input or the sync cable can be combined to create a trigger input for each trigger block. The four gate signals can be used to suppress triggers during certain time frames.

2.4.4 Gating Blocks

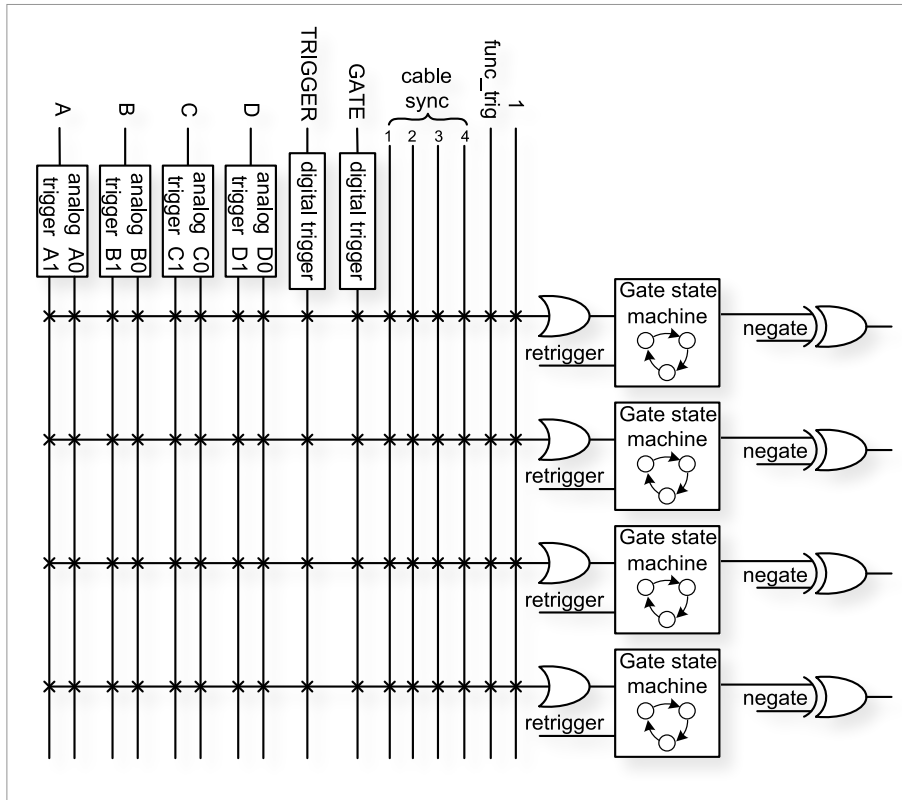

Figure 2.20: Gating Blocks: Each gating block can use an arbitrary combination of inputs to trigger its state machine. The outputs can be individually inverted and routed to the AND-gate feeding the trigger blocks.

In order to decrease the amount of data transmitted to the PC, **Ndigo5G** includes four independent gate and delay units. A gate and delay unit creates a gate window starting at a specified time after a trigger, closing the window at gate stop. Both timing values - gate start and gate stop - must be set as multiples of **3.2ns**.

Trigger blocks can use the gate signal to suppress data acquisition: Only data that fulfills zero suppression specifications occurring in an active gate window is written to the PC.

As input, any trigger from the 4 trigger blocks, the GATE and Trigger inputs, a trigger from a connected board and the function generator can be used.

The retrigger feature will create a new gate if a trigger occurs during an active gate window. The gate signal can be inverted, causing an active gate to close for a time defined by the user.

The parameters of a gating block are set in structure **ndigo_gating_block** [described on page 38](#).

[Figure 2.21](#) shows the functionality of the gate timing and delay unit. Active gate time is marked in green.

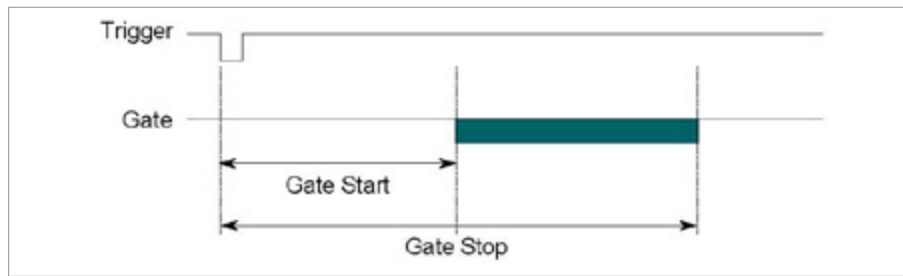

Figure 2.21: Gate and delay functionality: When a trigger occurs, the gate opens after a set period of time ("gate start") and closes when it reaches "gate stop".

Gating Example 1: Suppression of Noise After Starting an Acquisition

In mass spectrometer and other experiments, noise while starting data acquisition can result in undesired trigger events for that time period. To prevent noise in the output data, a gating block could be used to suppress all triggers during start-up.

The example in [Figure 2.22](#) illustrates the use of a gating block to prevent noise: The **GATE input** transmits a pulse on each acquisition start. The **trigger structure** of the **GATE input** is used to select pulse polarity. Then, the GATE trigger is selected as gating block input and the gating block's start parameter is set to **0**. The stop parameter is set to the desired length measured in **3.2ns** clock cycle and negate is set to **true**. The gating block will now output a low pulse of the desired length whenever there is a pulse on the GATE input.

Enable this gating block as an AND input to the trigger block, for which noise shall be suppressed.

Gating Example 2: Delayed Trigger

To sample a short window at a specified time after a trigger event on a channel, the gating block can be used to create a delayed trigger. To do this, one of the triggers of the channel of interest is configured to the desired parameters by selecting the threshold, setting the edge polarity and enabling edge triggering.

Instead of directly using this trigger as input to the trigger block's input matrix, the trigger is selected as an input to a gating block. The block is configured to **start = delay** [in **3.2ns** clock cycles] and **stop = start + 1**, **negate = false**. This causes the gating block to produce a one clock cycle pulse on its output after the specified delay. To send this pulse to the trigger block, the gating block must be enabled in the trigger block's AND matrix and the ONE trigger source must be selected.

Gating Example 3: Dual Level Trigger

The gates provide AND connections between each other (see [fig. 2.19](#)) which can be used for example in a dual level trigger. For the acquisition of signal data with amplitudes between a lower and an upper bound, for example, two level triggers can be connected (see [fig. 2.22](#)): a falling level trigger with an upper threshold and a rising level trigger with a lower threshold.

Since the triggers are only connected by OR in the triggerblock logic (see [Figure 2.19](#)) they are assigned to one of the gates each and connected with AND via the gating block region of the trigger matrix (see [Figure 2.19](#) and [Figure 2.23](#)). Because of the dead times of the gates it is important to enable the retrigging feature. Furthermore a precursor of 2 clock cycles is needed, because the gates are delayed in relation to the ADC samples.

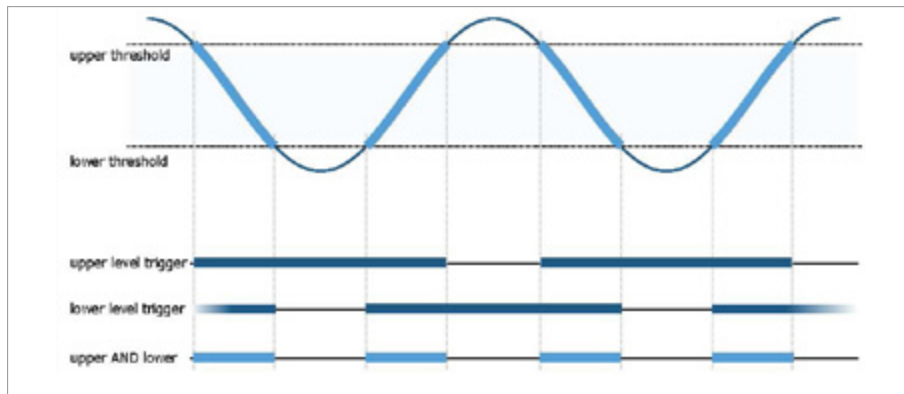

Figure 2.22: Measuring data with amplitude between an upper and a lower threshold by means of two level triggers.

Config settings can be found in the following code snippet:

```

1  config.trigger_block[0].enabled = 1;
2  config.trigger_block[0].precursor = 2;
3  config.trigger_block[0].length = 0;
4  config.trigger_block[0].sources = NDIGO_TRIGGER_SOURCE_ONE;
5  config.trigger_block[0].gates = NDIGO_TRIGGER_GATE_0 |
6     NDIGO_TRIGGER_GATE_1;
7  config.gating_block[0].retrigger = 1;
8  config.gating_block[0].stop = 0;
9  config.gating_block[0].sources = NDIGO_TRIGGER_A0;
10 config.gating_block[1].retrigger = 1;
11 config.gating_block[1].stop = 0;
12 config.gating_block[1].sources = NDIGO_TRIGGER_A1;
13 config.trigger[NDIGO_TRIGGER_A0].rising = 0;
14 config.trigger[NDIGO_TRIGGER_A0].threshold = 10000;
15 config.trigger[NDIGO_TRIGGER_A1].rising = 1;
16 config.trigger[NDIGO_TRIGGER_A1].threshold = -10000;

```

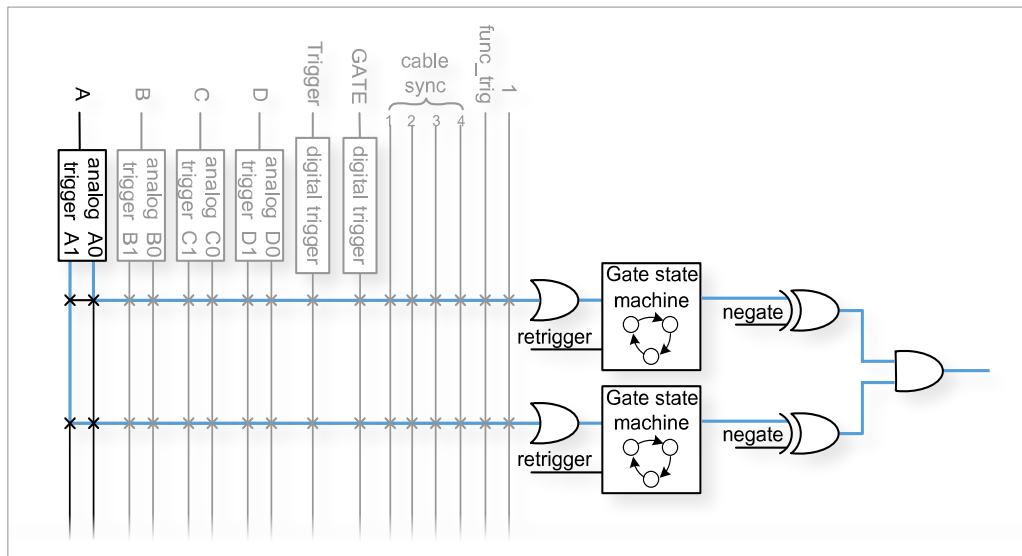

Figure 2.23: Gating block logic for the AND connection of two triggers.

2.4.5 Auto Triggering Function Generator

Some applications require periodic or random triggering. **Ndigo5G**'s function generator provides this functionality.

The delay between two trigger pulses of this trigger generator is the sum of two components: A fixed value M and a pseudo random value given by the exponent N .

The period is

$$T = 1 + M + [1 \dots 2^N] \quad (2.1)$$

clock cycles with a duration of **3.2 ns** per cycle.

This allows to monitor input signals at times the current trigger configuration does not trigger, e. g. to get base line information in mass spectrometry applications. It can also be used to determine a suitable threshold level for the trigger by first getting random statistics on the input signal.

2.4.6 Timestamp Channel

The timestamp channel produces a stream of small packets that denote the time of the trigger event. An arbitrary set of trigger sources can be selected in the trigger matrix to cause the creation of a packet.

The packets have a fixed length of 16 bytes. The format is [described on page 41](#). The length field of the packet contains a 32 bit pattern that contains the levels of all trigger sources at the time of the trigger event except for the period monitor. Only one packet is created, no matter how many trigger sources caused the timestamp channel to trigger.

2.4.7 Data Lookup Table

In some applications it might be useful to modify the ADC sample data by a user defined function $f(x)$. In this case the onboard FPGA is able to perform this task such that the data stream consists of data words $f(\text{sample})$ instead of $f(\text{sample})$. The function $f(x)$ is applied using a 1024 word lookup table (LUT) which needs to be provided by the user. This is done by dening the corresponding function as a **custom_lut-member** of the **ndigo_configuration** structure. Please feel free to contact **cronologic** if you plan the use this feature. The onboard INL correction is applied prior to mapping the LUT values.

2.5 Multiple Ndigo boards synchronization

Using several Ndigo devices in applications that use more channels than a single board can provide requires synchronized operation. To ensure exact synchronization, a delay parameter needs to be set for each board. This parameter might change in case boards are swapped, added or removed and in some cases might change after a firmware update.

The calibration tool **MultiboardCalibration.exe** is available after installing the Ndigo device driver. It is used to nd appropriate delay values for each board in a given board setup. After starting, the application lists all Ndigo boards found ([Figure 2.24](#)).

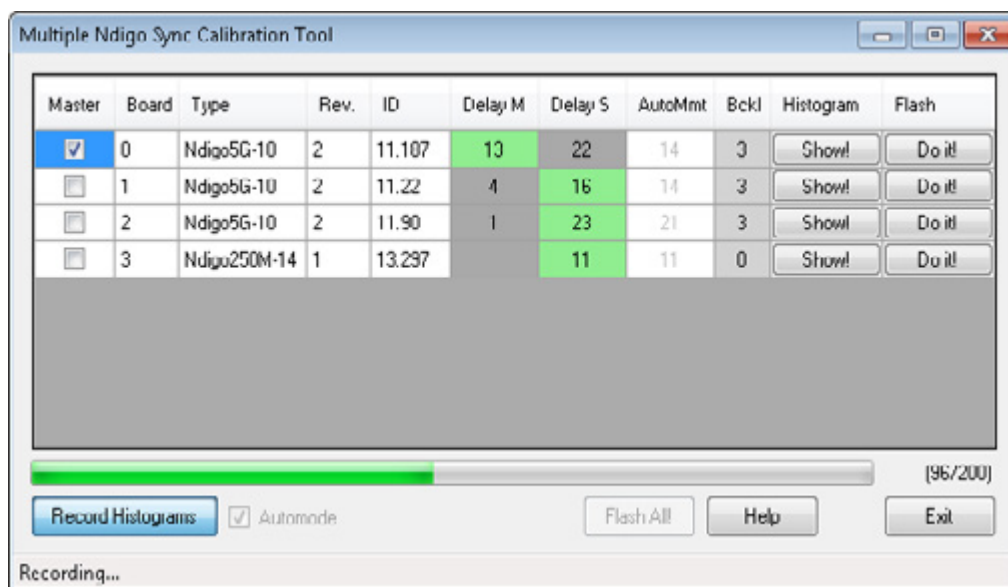

Figure 2.24: Main window of the multiple boards sync calibration tool

A board's appropriate delay depends on whether it operates in master or slave mode. The respective values can be set in the column **Delay M** (for master boards) and **Delay S** (for slave boards). The designated master board can be selected in the column "Master". The calibration procedure creates a histogram for each board displaying the current delay between the boards. The histogram can be viewed by clicking on "Show!". When the appropriate delay values are found they can be stored in the on-board flash PROM by clicking **Do it!** separately for each board. Clicking **Flash All!** will write the values to all boards at once. Please note: Flashing the values might take up to 10 seconds during which the program might not respond.

Important note: If the application reports a **PLL not locked** error check the cable. If the recording of histograms does not make progress check the cable. Make sure the cable is properly terminated at both ends and rmlly attached to each card.

2.5.1 Calibration Procedure

1. Make sure the **Automode** is selected.
2. Record the calibration histograms by pressing **Record histograms**. The program will perform up to 200 measurements of the sync delay. After accumulating some data, the delay values found are reported in the column **AutoMmt**. The values can be verified by examining the histogram that was recorded. A board's histogram should look like the one shown in [Figure 2.25](#). During normal operation the delay will be adjusted such that the data points accumulated roughly coincide with the vertical markers in the upper panel. As the delay pattern is periodic valid delay values are between **0** and **31**. Thus, the delay value found by the auto measurement should correspond to the distance between the vertical markers and accumulated data points. Hint: When moving the mouse pointer across the histogram the delay value of the current location is displayed.
3. After stopping the data acquisition, by pressing **Record Histograms** again or waiting for 200 measurements to complete, the delay values of the auto measurement need to be copied to the columns **Delay M** or **Delay S** depending on the corresponding board being a master or a slave. The correct field to copy the value to is highlighted in green.
4. You may record a new dataset as a crosscheck that the delay is now set to an appropriate value. By disabling **Automode** the new delay values are used. Press **Record Histograms** in order to start the data acquisition. After some time the histogram should look similar to the one in [Figure 2.26](#).
5. The delay values for all boards in a set needs to be found. For the case a board acts as a master, the value **Delay M** needs to be adjusted, in case it is a slave, the **Delay S** parameter needs to be changed. In order to find the master-case delay values for all boards, the calibration procedure needs to be performed with every board acting as a master once. After changing the master board, the slave values of the other boards don't need to be readjusted. Only **Ndigo5G** boards may be set as masters. Therefore, a Ndigo250M board only needs to be calibrated as a slave.
6. After finding all delay values, write the values to the on-board flash PROMs by pressing **Flash All!**.

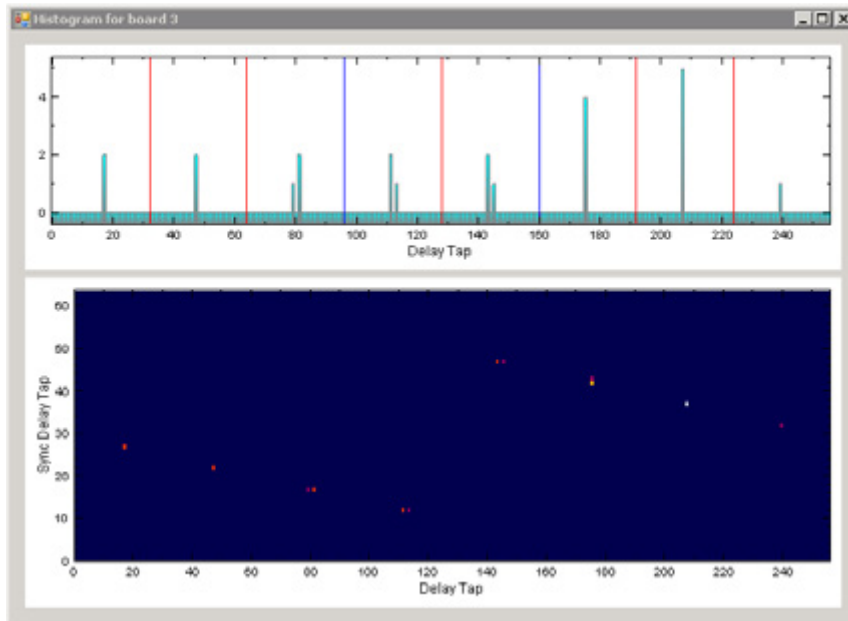

Figure 2.25: Histogram for the case the delay value for the board is not set correctly. Please note: the lower panel might differ from board to board, with the “step” being at a different position.

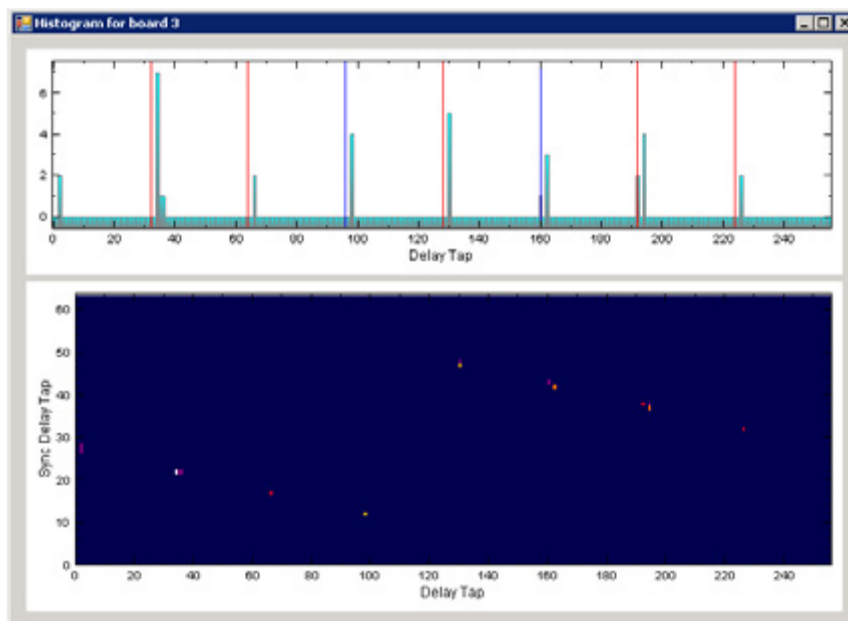

Figure 2.26: Histogram for the case the delay value for the board is set correctly. Please note: the lower panel might differ from board to board, with the “step” being at a different position.

2.5.2 Synchronizing a Ndigo5G and an HPTDC8-PCI

In order to operate a **Ndigo5G** in sync with one or more **HPTDC8-PCI** boards, a board to board interconnection using a **Ndigo Extension Board** needs to be done. The **Ndigo Extension Board** has four clock outputs. One of them needs to be connected to the external clock input of the HPTDC using a standard Lemo 00 cable. The **Ndigo5G** is connected to the **Ndigo Extension Board** using the Samtec ribbon cable provided with the **Ndigo Extension Board**. The signals used for synchronization of the boards are transmitted by a standard 10pin ribbon cable connecting the Ndigo Extension Board and the HPTDC. A schematic of all necessary connections is shown in [Figure 2.27](#).

In principle the user can use the standard device drivers of the **Ndigo5G** and the **HPTDC8-PCI** to perform data acquisition. It is, however, recommended to use the **cronoSync-library**, which is a part of the **cronoTools** provided with the **Ndigo5G** device driver. **CronoSync** offers an easy group-based access to the data recorded and handles the synchronization of all cronologic data acquisition devices used. A detailed description of **cronoTools** and **cronoSync** can be found in the **cronoTools** user guide.

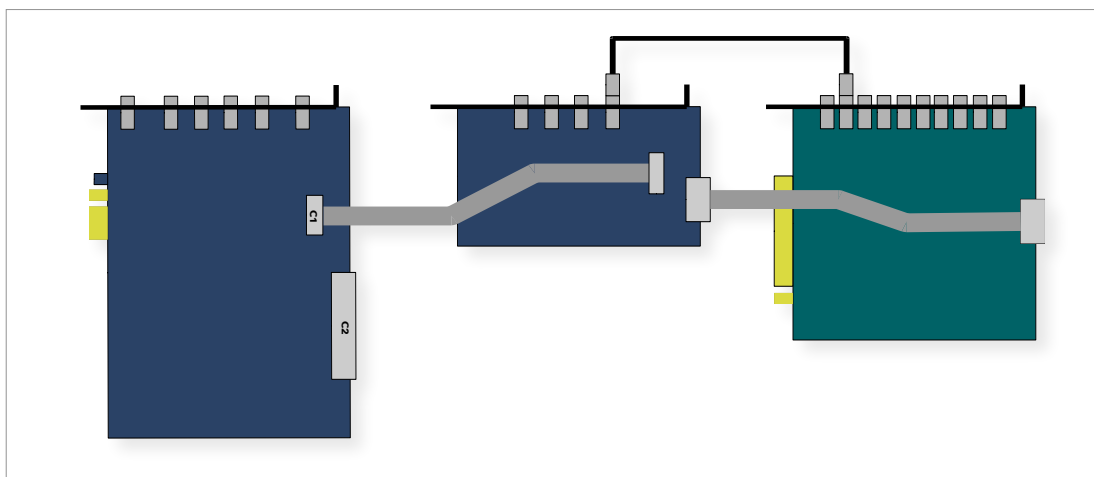

Figure 2.27: Interconnection scheme of a Ndigo5G (left) and a HPTDC8-PCI (right) using Ndigo Extension Board (middle).

2.6 Performing a firmware update

After installing the **Ndigo device driver**, a firmware update tool is available. By choosing **NdigoFirmwareGUI.exe** a firmware update can be performed. After invoking the application a window as shown in [Figure 2.28](#) will appear. The tool can be used for updating the firmware and to create a backup of the on-board calibration data of the **Ndigo** unit. If several boards are present, the one which is going to be used can be selected in the upper left corner of the window. Pressing the **Backup** buttons a backup of the firmware or the calibration data will be created, respectively. In order to perform a firmware update, chose the **.ndigorom**-file to be used by pressing **Browse**. The file contains the firmware PROMs for all boards of the **Ndigo** product line. By pressing **Flash** the firmware is written to the board. **Verify** can be used to compare the data stored inside the PROM to the one inside a file.

Important note: The new firmware will only be used after a power cycle, i.e. after switching the PC (or Ndigo crate) off and back on. A simple reboot is not sufficient.

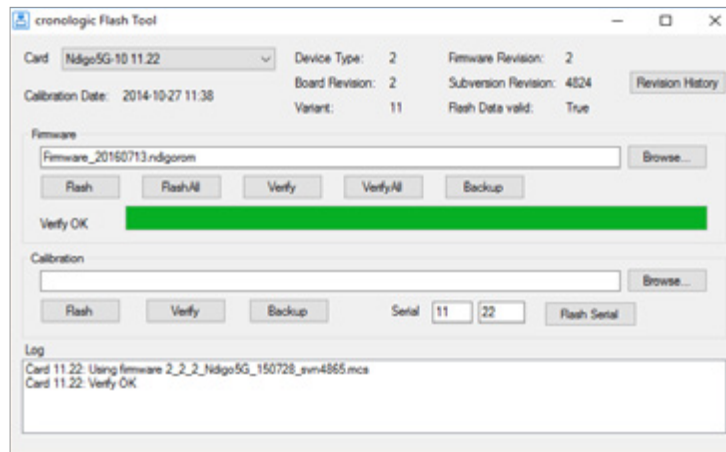

Figure 2.28: The firmware update and calibration data backup tool as provided with the Ndigo device driver.

Therefore the information shown in the upper half of the application window does not change right after flashing a new firmware.

After flashing and shutting the PC or the crate off and on again it is recommended to perform a window calibration. The tool **WindowCalibration** is provided for that purpose within the driver installation. The omission of the calibration process leads to longer execution times of applications using that firmware, since the calibration is performed then instead.

2.7 Calibrating the TDC

After each update of the **Ndigo5G-10** firmware the TDC has to be calibrated. The calibration is done with the tool **TDC Calibration.exe** which is available after installing the Ndigo device driver. After invoking the application a window as shown in [Figure 2.29](#) will appear.

The calibration procedure is as follows:

1. Connect an external pulse signal to the Trigger input. The signal should be low active with a frequency in the kHz range. It must not be synchronized to the clock source of the **Ndigo5G-10**. The input frequency must not exceed **10 MHz**. The pulse low and high width has to be at least **10ns** each.
2. Set **Serial Number** according to the sticker on the card if the shown value is not correct.
3. Start capturing pulse events by pressing the **Start** button.
4. Adjust the **Input Offset** so that **First Bin** is in the range of **4** to **16**.

If **First Bin** is less than **4**, increment **Input Offset** by one. If **First Bin** is greater than **16** decrement **Input Offset** by one. Repeat increment/decrement until **First Bin** is in the range of **4** to **16**. Depending on the firmware revision the **Input Offset** value for a successful calibration may be in the range of **6 - 10** or **28 - 32**.



Figure 2.29: The TDC calibration tool as provided with the Ndigo device driver.

5. When the **Write Calibration Data** button becomes enabled press it to update the calibration data on the card.
6. Calibration done!

The card can only be successfully calibrated if:

- **First Bin** is in the range of **4** to **16**
- **Empty Bins** is less than (**First Bin + 4**)
- at least 10,000 events have been captured
- a valid serial number is set.

Important note: If the application reports an error, check if the input pulse is within specification.

3.0 Driver Programming API

The API is a DLL with C linkage.

The functions provided by the DLL are declared in *Ndigo interface.h*.

3.1 Constants

#define NDIGO_CHANNEL_COUNT 4

The number of analog input channels.

#define NDIGO_GATE_COUNT 4

The number of gating blocks.

#define NDIGO_TRIGGER_COUNT 16

The number of triggers. Two per analog input, one per digital input plus some specials.

#define NDIGO_ADD_TRIGGER_COUNT 6

Additional set of triggers for digital inputs.

3.2 Initialization

int ndigo_count_devices(int *error_code, char **error message)

Return the number of boards that are supported by this driver in the system.

int ndigo_get_default_init_parameters(ndigo_init_parameters *init)

Get a set of default parameters to feed into *ndigo_init()*.

This must always be used to initialize the *ndigo_init_parameter* structure.

ndigo_device *ndigo_init(ndigo_init_parameters *params, int *error_code, char **error_message)

Open and initialize the Ndigo board with the given index. With *error_code* and *error_message* the user must provide pointers where to buffers where error information should be written by the driver. The buffer for the error message must be at least **80 chars** long.

Params is a structure of type *ndigo_init_parameters* that must be completely initialized.

int ndigo_close(ndigo_device *device)

Finalize the driver for this device.

3.2.1 Structure ndigo_init_parameters

int version

Must be set to *NDIGO_API_VERSION*

int card_index

The index in the list of *Ndigo5G* boards that should be initialized. There might be multiple boards in the system that are handled by this driver as reported by *ndigo_count_devices*.

This index selects one of them. Boards are enumerated depending on the PCIe slot.

The lower the bus number and the lower the slot number the lower the card index.

int board_id

This 8 bit number is filled into each packet created by the board and is useful if data streams of multiple boards will be merged. If only **Ndigo5G** cards are used, this number can be set to the card index. If boards of different types that use a compatible data format are used in a system, each board should get a unique id.

Can be changed with ***int ndigo_set_board_id(ndigo_device*device, int board_id)***.

ndigo_bool_t use_external_clock

Use 10MHz clock supplied by IPC flat band cable. Must be set for all slaves.

ndigo_bool_t drive_external_clock

Drive internal 10MHz clock of this board to IPC flat band cable. Must be set for master.

ndigo_bool_t is_slave

Data acquisition of this board is controlled by the master board.

int sync_period

Period of the multicard sync pulse. Should be set to **4** (default) when using several Ndigo boards in sync. Ignored for single board setups. The **Ndigo5G** has 4 phases relative to the global 10MHz clock.

int sync_delay

Fine tap delay for incoming sync signals.

ndigo_bool_t force_window_calibration

If **true/1**, valid data window is detected at initialization. Default value is **false/0**: values from flash memory are used in order to set data window to correct position.

ndigo_bool_t hptdc_sync_enabled

A **HPTDC** is connected to this board. Enables the clock and sync line from the **Ndigo5G** to the **HPTDC**.

__int64 buffer_size[8]

The minimum size of the DMA buffer. If set to **0** the default size of 16MByte is used. **Ndigo5G** only uses **buffer_size[0]**.

int buffer_type

Must be set to **NDIGO_BUFFER_ALLOCATE**.

__int64 buffer_address

Ignored. Might be used for future buffer types.

int variant

Set to 0. Can be used to activate future device variants such as different base frequencies.

int device_type

Initialized by **ndigo_get_default_init_parameters()**. Must be left unchanged.

```
#define CRONO_DEVICE_HPTDC 0
#define CRONO_DEVICE_NDIGO5G 1
#define CRONO_DEVICE_NDIGO250M 2
```

int_dma read_delay

Initialized by **ndigo_get_default_init_parameters()**. The write pointer update is delay by this number of **4 ns** clock periods to hide race conditions between software and DMA.

3.3 Status Information

3.3.1 Functions for Information Retrieval

The driver provides functions to retrieve detailed information on the type of board, its configuration, settings and state. The information is split according to its scope and the computational requirements to query the information from the board.

int ndigo_get_driver_revision()

Returns the driver version, same format as ***ndigo_static_info::driver_revision***. This function does not require a present ***Ndigo5G*** device.

const char* ndigo_get_driver_revision_str()

Returns the driver version including SVN build revision as a string. This function does not require a present ***Ndigo5G*** device.

int ndigo_get_static_info(ndigo_device *device, ndigo_static_info *info)

This structure contains information about the board that does not change during run time.

int ndigo_get_param_info(ndigo_device *device, ndigo_param_info *info)

The structure returned by this call contains information that changes indirectly due to configuration changes.

int ndigo_get_fast_info(ndigo_device *device, ndigo_fast_info *info)

This call returns a structure that contains dynamic information that can be obtained within a few microseconds.

int ndigo_get_slow_info(ndigo_device *device, ndigo_slow_info *info)

The data reported in this structure requires milliseconds to be obtained. The application should only call it in situation where the program flow can cope with an interruption of that magnitude.

const char* ndigo_get_last_error_message(ndigo_device *device)

3.3.2 Structure ***ndigo_static_info***

This structure contains information about the board that does not change during run time. It is provided by the function ***ndigo_get_static_info***.

int size

The number of bytes occupied by the structure

int version

A version number that is increased when the definition of the structure is changed. The increment can be larger than one to match driver version numbers or similar. Set to **0** for all versions up to first release.

int board_id

Index of the board as passed to the constructor or set via

int ndigo_set_board_id(ndigo_device *device, int board_id).

int driver_revision

The lower three bytes contain a triple level hierarchy of version numbers, e.g. **0x010103** encodes **version 1.1.3**.

A change in the first digit generally requires a recompilation of user applications. Change in the second digit denote significant improvements or changes that don't break compatibility and the third digit changes with minor bugfixes and similar updates.

int firmware_revision

Firmware revision of the FPGA configuration. This increments only when there is a functional change.

int board_revision

0 for experimental prototypes labeled **Rev. 1**

2 for the version produced until 2010 labeled **Rev. 2**

3 for the version produced starting in 2011 labeled **Rev. 3**

int board_configuration

Describes the schematic configuration of the board.

For **board revision 0** this always reads **0**.

For **board revision 2** the following assignments are valid:

If **Bit 3 = 0** this following is valid:

Bit 0 determines the ADC resolution. (**0 = 8 - bit** or **1 = 10 - bit**).

Bit 1 determines whether the TDC-oscillator is present (**0 = oscillator present**, **1 = simple trigger**).

Bit 2 determines the input connectors (**0 = single ended**, **1 = differential**).

Bit 3 = 1 signifies a special version of the board

0xA is **Ndigo1250M-12** single ended with digital trigger

0x8 is **Ndigo5G-8** single ended with digital trigger

For Board revision 3 the following assignments are valid:

Bit 2 determines the input connectors (**0 = single ended**, **1 = differential**).

The other bits have one of the following patterns [**Bits 3...0**]

0010 Ndigo5G-10 2.5u 10

0011 Ndigo5G-8-AQ 2.5u 8

0110 Ndigo5G-10-Di 560pF 10 DIFF

1000 Ndigo5G-8 560pF 8+

1010 Ndigo1250M-12 2.2uF 12 Sciex DC

1011 Ndigo5G-10 560pF 10

1110 Ndigo5G-Sciex 2.2uF 10 Sciex Inniband, DIFF

1111 Ndigo5G-Roent = fADC4/10 560pF 10

int adc_resolution

Number of bits of the ADC, set to **0** if unknown.

double nominal_sample_rate

Sample rate in once channel mode. Usually **5.0e9 = 5Gsps**.

double analog_bandwidth

3e9 for **3Ghz**

int chip_id

16 bit factory ID of the ADC chip

int board_serial

Serial number with the year minus 2000 in the highest 8 bits of the integer and a running number in the lower 24 bits. This number is identical with the one on the label on the board.

int flash_serial_low**int flash_serial_high**

64 bit manufacturer serial number of the flash chip.

int flash_valid

If not **0**, the driver found valid calibration data in the flash on the board and is using it.

ndigo bool_t_dc_coupled

Returns false for the standard AC coupled **Ndigo5G**.

int subversion_revision

A number to track builds of the firmware in more detail than the firmware revision. It changes with every change in the firmware, even if there is no visible effect for the user.

char calibration_date[20]

DIN EN ISO 8601 string YYYY-MM-DD HH:DD describing the time when the card was calibrated.

3.3.3 Structure **ndigo_param_info**

int size

The number of bytes occupied by the structure.

int version

A version number that is increased when the definition of the structure is changed. The increment can be larger than one to match driver version numbers or similar. Set to **0** for all versions up to first release.

double bandwidth

Analog Bandwidth setting of the ADC. Either **3e9 = 3GHz** or **1e9 = 1GHz** for 10 bit version.

double sample_rate

Sample rate. This is **1.25e9**, **2.5e9** or **5.0e9** depending on the current ADC mode.
 $\text{sample_rate} \cdot \text{channels} = 5.0e9$.

double sample_period

The period one sample in the data represents in picoseconds

int board_id

The number the board uses to identify the data source in the output data stream.

int channels

Number of channels. 1, 2 or 4 depending on the ADC mode chosen.
 $\text{sample_rate} \cdot \text{channels} = 5.0e9$.

int channel_mask

Mask with a set bit for each enabled input channel.

int64 total_buffer

The total amount of the DMA buffer in bytes.

3.3.4 Structure ndigo fast info

int size

The number of bytes occupied by the structure

int version

A version number that is increased when the definition of the structure is changed. The increment can be larger than one to match driver version numbers or similar. Set to **0** for all versions up to first release.

int adc_rpm

Speed of the ADC fan. Reports **0** if no fan is present.

int fpga_rpm

Speed of the FPGA fan. Reports **0** if no fan is present.

int alerts

Alert bits from the system monitor.

Bit 0 : FPGA temperature alert ($> 85^{\circ}\text{C}$)

Bit 1 : Internal FPGA voltage out of range ($< 1.01\text{V}$ or $> 1.08\text{V}$)

Bit 2 : FPGA auxiliary voltage out of range. ($< 2.375\text{V}$ or $> 2.625\text{V}$)

Bit 3 : FPGA temperature critical ($> 125^{\circ}\text{C}$)

Bit 4 : ADC temperature alert ($> 90^{\circ}\text{C}$)

Bit 5 : ADC temperature critical ($> 100^{\circ}\text{C}$): will automatically be turned off.

double voltage_aux

Auxiliary FPGA voltage, nominal **2.5V**

double voltage_int

Internal FPGA voltage, nominal **1.0V**

double fpga_temperature

In $^{\circ}\text{C}$ measured on die.

int pcie_link_width

Number of PCIe lanes that the card uses. Should be 4 for **Ndigo5G**.

int pcie_max_payload

Maximum size in bytes for one PCIe transaction, depends on system configuration.

3.3.5 Structure ndigo slow info

int size

The number of bytes occupied by the structure.

int version

A version number that is increased when the definition of the structure is changed. The increment can be larger than one to match driver version numbers or similar. Set to **0** for all versions up to first release.

double adc_temperature

ADC temperature in $^{\circ}\text{C}$ measured on die.

double board_temperature

In $^{\circ}\text{C}$.

3.4 Configuration

The device is configured with a configuration structure. The user should first obtain a structure that contains the default settings of the device read from an on board ROM, then modify the structure as needed for the user application and use the result to configure the device.

int ndigo_get_default_configuration(ndigo_device *device, ndigo_configuration *config)

int ndigo_get_current_configuration(ndigo_device *device, ndigo_configuration *config)

int ndigo_configure(ndigo_device *device, ndigo_configuration *config)

int ndigo_set_board_id(ndigo_device *device, int board_id)

The ***board_id*** can be changed after initialization of the card. If cronotools are used, the ***board_id*** changes have to be done before cronotools initialization.

3.4.1 Structure ndigo configuration

This is the structure containing the configuration information. It is used in conjunction with ***ndigo_get_default_configuration***, ***ndigo_get_current_configuration*** and ***ndigo_configure***.

It uses internally the structures ***ndigo_trigger_block*** and ***ndigo_trigger***.

int size

The number of bytes occupied by the structure.

int version

A version number that is increased when the definition of the structure is changed. The increment can be larger than one to match driver version numbers or similar. Set to **0** for all versions up to first release.

int reserved1

Reserved for internal usage. Do not change.

int adc mode

Constant describing the ADC mode

```
#define NDIGO_ADC_MODE_ABCD 0
#define NDIGO_ADC_MODE_AC 4
#define NDIGO_ADC_MODE_BC 5
#define NDIGO_ADC_MODE_AD 6
#define NDIGO_ADC_MODE_BD 7
#define NDIGO_ADC_MODE_A 8
#define NDIGO_ADC_MODE_B 9
#define NDIGO_ADC_MODE_C 10
#define NDIGO_ADC_MODE_D 11
#define NDIGO_ADC_MODE_AAAA 12
#define NDIGO_ADC_MODE_BBBB 13
#define NDIGO_ADC_MODE_CCCC 14
#define NDIGO_ADC_MODE_DDDD 15
#define NDIGO_ADC_MODE_A12 28 // not available on all boards
#define NDIGO_ADC_MODE_B12 29 // not available on all boards
#define NDIGO_ADC_MODE_C12 30 // not available on all boards
#define NDIGO_ADC_MODE_D12 31 // not available on all boards
```

double bandwidth

Set to the minimum bandwidth required for the application. Lower bandwidth results in reduced noise. The driver will set the ADC to the minimum setting that has at least the desired bandwidth and report the selected bandwidth in the ***ndigo_param_info*** structure. The -8, -10 and -12 versions currently supports **1GHz** and **3GHz** bandwidth, the -8AQ version supports **2GHz**, **1.5GHz**, **600MHz** and **500 MHz**.

ndigo_bool_t reserved

ndigo_bool_t tdc_enabled

Enable capturing of TDC measurements on external digital input channel.

ndigo_bool_t tdc_fb_enabled

Enable enhanced TDC resolution. Currently not implemented.

double analog_offset[NDIGO_CHANNEL_COUNT]

Sets the input DC offset-values to **+ - this value in volts**. Defaults to **0**.

double dc_offset[2]

Sets the DC offset in volts for the TDC trigger input (index **1**) and the GATE input (index **0**). The trigger threshold is zero. For **negative 0.8V NIM** pulses a value of **0.4** should be set here.

ndigo_trigger_trigger[NDIGO_TRIGGER_COUNT + NDIGO_ADD_TRIGGER_COUNT]

Configuration of the external trigger sources. Threshold is ignored for entries **8 and above**.

The trigger indexes refer to the entry in the trigger array and are defined like this:

```
#define NDIGO_TRIGGER_A0 0
#define NDIGO_TRIGGER_A1 1
#define NDIGO_TRIGGER_B0 2
#define NDIGO_TRIGGER_B1 3
#define NDIGO_TRIGGER_C0 4
#define NDIGO_TRIGGER_C1 5
#define NDIGO_TRIGGER_D0 6
#define NDIGO_TRIGGER_1 7
#define NDIGO_TRIGGER_TDC 8
#define NDIGO_TRIGGER_GATE 9
#define NDIGO_TRIGGER_BUS0 10
#define NDIGO_TRIGGER_BUS1 11
#define NDIGO_TRIGGER_BUS2 12
#define NDIGO_TRIGGER_BUS3 13

#define NDIGO_TRIGGER_UTO 14
#define NDIGO_TRIGGER_ONE 15
```

Always positive edge-sensitive sources:

```
#define NDIGO_TRIGGER_TDC PE 16
#define NDIGO_TRIGGER_GATE PE 17
#define NDIGO_TRIGGER_BUS0 PE 18
#define NDIGO_TRIGGER_BUS1 PE 19
#define NDIGO_TRIGGER_BUS2 PE 20
#define NDIGO_TRIGGER_BUS3 PE 21
```

ndigo_trigger_block trigger_block[NDIGO_CHANNEL_COUNT + 1]

A structure describing the trigger settings of the four channels plus the timestamp channel. In some modes not all channels are used.

ndigo_gating_block gating_block[4]

A structure describing the gating blocks that can be used by the trigger blocks to filter triggers.

ndigo_extension_block extension_block[NDIGO_EXTENSION_COUNT]

A structure describing the routing of the 4 digital channels of the **Ndigo extension board** to the trigger matrix.

int drive_bus[4]

Enable output drive for each of the four external sync lines.

Each integer represents a bitmask selecting the trigger sources for that line.

The bit mapping is described in section [Structure ndigo_trigger_block on page 36](#).

int auto_trigger_period

int auto_trigger_random_exponent

Create a trigger either periodically or randomly. There are two parameters

M = trigger_period and **N** = random_exponent that result in a distance between triggers of

$$T = 1 + M + [1 \dots 2^N] \quad (3.1)$$

clock cycles.

$$0 \leq M < 2^{32} \quad (3.2)$$

$$0 \leq N < 32 \quad (3.3)$$

There is no enable or reset as the usage of this trigger can be configured in the trigger block channel source field.

int output_mode

Defines the data representation in the output. **Signed16** scales and INL-corrects the input.

RAW directly presents the ADC values.

```
#define NDIGO_OUTPUT_MODE_SIGNED16 0
#define NDIGO_OUTPUT_MODE_RAW 1
#define NDIGO_OUTPUT_MODE_CUSTOM 2
#define NDIGO_OUTPUT_MODE_CUSTOM_INL 3
```

lut_func custom_lut

Lookup table. If the output_mode is set to **NDIGO_OUTPUT_MODE_CUSTOM** or to **NDIGO_OUTPUT_MODE_CUSTOM_INL**, this function is used for mapping from ADC value to output value. The driver will call this function with a value from **-1** to **+1** and the function must return the corresponding signed 16 bit value that the board should return for an input voltage relative to the full scale range.

typedef short (*lut_func)(int channel, float x)

This can be used e.g. for custom INL, offset and gain correction that covers user front end electronics. It can also invert the signal or correct the effect of logarithmic input amplifiers etc.

The LUT is applied on the board, thus using it does not cause any additional CPU load.

In the mode **NDIGO_OUTPUT_MODE_CUSTOM_INL** the on-board INL correction table is applied before the user function, while **NDIGO_OUTPUT_MODE_CUSTOM** does not perform INL correction. In order to use the user lookup table functionality, **lut_func** must be set to a pointer to the LUT-function.

3.4.2 Structure ndigo trigger

short threshold

Sets the threshold for the trigger block within the range of the ADC data of **-32768** and **+32768**.

For trigger indices **NDIGO_TRIGGER_TDC** to **NDIGO_TRIGGER_BUS3_PE** the threshold is ignored.

ndigo_bool_t edge

If set this trigger implements edge trigger functionality else this is a level trigger.

For trigger indices **NDIGO_TRIGGER_AUTO** and **NDIGO_TRIGGER_ONE** this is ignored.

For trigger indices **NDIGO_TRIGGER_TDC_PE** to **NDIGO_TRIGGER_BUS3_PE** this must be set.

ndigo_bool_t rising

If set trigger on rising edges or when above threshold.

For trigger indices **NDIGO_TRIGGER_AUTO** and **NDIGO_TRIGGER_ONE** this is ignored.

For trigger indices **NDIGO_TRIGGER_TDC_PE** to **NDIGO_TRIGGER_BUS3_PE** this must be set.

3.4.3 Structure ndigo_trigger_block

ndigo_bool_t enabled

Activate triggers on this channel.

ndigo_bool_t retrigger

If a new trigger condition occurs while the postcursor is acquired, the packet is extended by starting a new postcursor. Otherwise the new trigger is ignored and the packet ends after the precursor of the first trigger.

The retrigger setting is ignored for the timestamp channel.

ndigo_bool_t reserved1

Defaults to false. Do not change.

ndigo_bool_t reserved2

Defaults to false. Do not change.

int precursor

Precursor in multiples of **3.2ns**. The amount of data preceding a trigger that is captured.

The precursor setting is ignored for the timestamp channel.

int length

In multiples of **3.2ns**.

The total amount of data that is recorded in addition to the trigger window. Precursor determines how many of these are ahead of the trigger and how many are appended after the trigger. In **edge trigger mode** the trigger window always is **3.2ns** wide, in **level trigger mode** it is as long as the trigger condition is fulfilled.

The length setting is ignored for the timestamp channel.

int sources

A bit mask with a bit set for all trigger sources that can trigger this channel.

```
#define NDIGO_TRIGGER_SOURCE_A0      0x00000001
#define NDIGO_TRIGGER_SOURCE_A1      0x00000002
#define NDIGO_TRIGGER_SOURCE_B0      0x00000004
#define NDIGO_TRIGGER_SOURCE_B1      0x00000008
#define NDIGO_TRIGGER_SOURCE_C0      0x00000010
#define NDIGO_TRIGGER_SOURCE_C1      0x00000020
#define NDIGO_TRIGGER_SOURCE_D0      0x00000040
#define NDIGO_TRIGGER_SOURCE_D1      0x00000080
#define NDIGO_TRIGGER_SOURCE_TDC     0x00000100
#define NDIGO_TRIGGER_SOURCE_GATE    0x00000200
#define NDIGO_TRIGGER_SOURCE_BUS0    0x00000400
#define NDIGO_TRIGGER_SOURCE_BUS1    0x00000800
#define NDIGO_TRIGGER_SOURCE_BUS2    0x00001000
#define NDIGO_TRIGGER_SOURCE_BUS3    0x00002000
#define NDIGO_TRIGGER_SOURCE_AUTO    0x00004000
#define NDIGO_TRIGGER_SOURCE_ONE     0x00008000
#define NDIGO_TRIGGER_SOURCE_TDC PE  0x01000000
#define NDIGO_TRIGGER_SOURCE_GATE PE 0x02000000
#define NDIGO_TRIGGER_SOURCE_BUS0 PE 0x04000000
#define NDIGO_TRIGGER_SOURCE_BUS1 PE 0x08000000
#define NDIGO_TRIGGER_SOURCE_BUS2 PE 0x10000000
#define NDIGO_TRIGGER_SOURCE_BUS3 PE 0x20000000
```

int gates

```
#define_NDIGO_TRIGGER_GATE_NONE      0x0000
#define_NDIGO_TRIGGER_GATE_0         0x0001
#define_NDIGO_TRIGGER_GATE_1         0x0002
#define_NDIGO_TRIGGER_GATE_2         0x0004
#define_NDIGO_TRIGGER_GATE_3         0x0008
```

double minimum_free_packets;

This parameter sets how many packets are supposed to fit into the on-board FIFO before a new packet is recorded after the FIFO was full, i.e. a certain amount of free space in the FIFO is demanded before a new packet is written after the FIFO was full.

As a measure for the packet length the gatelength set by the user is used. The on-board algorithm checks the free FIFO space only in case the FIFO is full. Therefore, if this number is **1.0** or more, at least every second packet in the DMA buffer is guaranteed to have the full length set by the gatelength parameters. In many cases smaller values will also result in full length packets. But below a certain value multiple packets that are cut off at the end will show up.

3.4.4 Structure ndigo gating block

ndigo_bool_t negate

Invert output polarity. Defaults to false.

ndigo_bool_t retrigger

Defaults to false. If retriggering is enabled, the timer is reset to the value of the start parameter whenever the input signal is set while waiting to reach the stop time.

ndigo_bool_t extend

Defaults to true. If set, a gate is created with the set timing from the first occurrence of the input trigger even for short gates. If not set, the input signal must persist for the gate to be created. This feature is **NOT YET IMPLEMENTED**.

ndigo_bool_t reserved1

Defaults to false. Do not change.

int start

In multiples of **3.2ns**. The time from the first input signal seen in the idle state until the gating output is set. The value of start needs to be less or equal to the stop value. Maximum value for start and stop is $2^{16} - 1$.

int stop

In multiples of **3.2ns**. Maximum allowed value is $2^{16} - 1$.

The time from leaving the idle state until the gating output is reset. If retriggering is enabled, the timer is reset to the value of the start parameter whenever the input signal is set while waiting to reach the stop time.

int sources

A bit mask with a bit set for all trigger sources that can trigger this channel. The gates cannot use the additional digital trigger sources **NDIGO_TRIGGER_SOURCE_TDC_PE** to **NDIGO_TRIGGER_SOURCE_BUS3_PE**.

```
#define NDIGO_TRIGGER_SOURCE_A0      0x00000001
#define NDIGO_TRIGGER_SOURCE_A1      0x00000002
#define NDIGO_TRIGGER_SOURCE_B0      0x00000004
#define NDIGO_TRIGGER_SOURCE_B1      0x00000008
#define NDIGO_TRIGGER_SOURCE_C0      0x00000010
#define NDIGO_TRIGGER_SOURCE_C1      0x00000020
#define NDIGO_TRIGGER_SOURCE_D0      0x00000040
#define NDIGO_TRIGGER_SOURCE_D1      0x00000080
#define NDIGO_TRIGGER_SOURCE_TDC     0x00000100
#define NDIGO_TRIGGER_SOURCE_GATE    0x00000200
#define NDIGO_TRIGGER_SOURCE_BUS0    0x00000400
#define NDIGO_TRIGGER_SOURCE_BUS1    0x00000800
#define NDIGO_TRIGGER_SOURCE_BUS2    0x00001000
#define NDIGO_TRIGGER_SOURCE_BUS3    0x00002000
#define NDIGO_TRIGGER_SOURCE_AUTO    0x00004000
#define NDIGO_TRIGGER_SOURCE_ONE     0x00008000
```

3.4.5 Structure `ndigo` extension block

This structure configures how the inputs from the optional extension board and signals from the synchronization bus are merged.

`ndigo_bool_t enable`

Enable routing of digital signal from `Ndigo` extension board to the according **`BUSx`** trigger unit.

`ndigo_bool_t ignore_cable`

If **`false`** input signal and `BUS` signal are **OR**ed before routing to the according **`BUSx`** trigger unit. Otherwise only the signal from **`Ndigo extension board`** is used.

3.4.6 Run Time Control

`int ndigo_start_capture(ndigo_device *device)`

`int ndigo_pause_capture(ndigo_device *device)`

`int ndigo_continue_capture(ndigo_device *device)`

Call this to resume data acquisition after a call to **`ndigo_pause_capture`**.

`int ndigo_stop_capture(ndigo_device *device)`

3.5 Readout

`int ndigo_read(ndigo_device *device, ndigo_read_in *in, ndigo_read_out *out)`

Return a pointer to an array of captured data in **`read_out`**. The result can contain any number of packets of type **`ndigo_packet`**. **`read_in`** provides parameters to the driver. A call to this method automatically allows the driver to reuse the memory returned in the previous call.

Returns an error code as defined in the structure **`ndigo_read_out`**.

`int ndigo_acknowledge(ndigo_device *device, ndigo_packet *packet)`

Acknowledge all data up to the packet provided as parameter. This is mandatory if **`acknowledge_last_read`** in the **`ndigo_read_in`** structure is set to **`false`** for calls to **`ndigo_read`**.

This feature allows to either free up partial DMA space early if there will be no call to **`ndigo_read`** anytime soon. It also allows to keep data over multiple calls to **`ndigo_read`** to avoid unnecessary copying of data.

`int ndigo_process_tdc_packet(ndigo_device *device, ndigo_packet *packet)`

Call on a TDC packet to update the timestamp of the packet with a more accurate value. If called more than once on a packet the timestamp will be invalid.

3.5.1 Input Structure `ndigo read in`

`ndigo_bool_t acknowledge_last_read`

If set **`ndigo_read`** automatically acknowledges packets from the last read.

3.5.2 Input Structure ndigo read out

ndigo_packet *first_packet

Pointer to the first packet that was capture by the call of ***ndigo_read***.

ndigo_packet *last_packet

Address of header of the last packet in the buffer.

int error_code

```
#define NDIGO_READ_OK 0
```

```
#define NDIGO_READ_NO_DATA 1
```

```
#define NDIGO_READ_INTERNAL_ERROR 2
```

const char *error_message

3.6 Other Functions

3.6.1 LED control

There are six LEDs on the front panel. The intensity of the red and green part can be set from **0** to **255**. There is no blue component in the current version. Per default all LEDs are set to **auto mode**. This means that used channels are lit **green**, activity is shown as **yellow** on overflow is shown as **red**.

int ndigo_set_led_color(ndigo device *device, int led, unsigned short r, unsigned short g, unsigned short b)

Set the LED to the selected color. No automatic updates are performed.

int ndigo set led automode(ndigo device *device, int led)

Let the selected LED be controlled by hardware.

4.0 Packet Format

4.0.1 Output Structure ndigo packet

unsigned char channel

0 to **3** for the ADC input channels, **4** for the TDC, **5** for the timestamp channel.

unsigned char card

Identifies the source card in case there are multiple boards present. Defaults to **0** if no value is assigned to the parameter board id in structure *ndigo_init_parameters* or set via *int ndigo_set_board_id(ndigo device *device, int board id)*.

unsigned char type

For the ADC channels this is set to **1** to signify **16 bit signed** data.

For the TDC channel it is set to **8** to signify **64 bit unsigned** data.

If the type field is 128 or greater, then there is no data present, even if length is not **0**.

In this cases the length field may contain other data.

Type	Length Field	Description
1	Number of payload words	16 bit signed samples from one of the ADCs
8	Number of payload words	64 Bit unsigned TDC Data, only for internal processing
128	Bit pattern of trigger sources	Whenever at least one of the sources that is enabled for the timestamp channel triggers, one of these packets is generated. The length field contains the triggers active when this packet was created.

unsigned char flags

```
#define NDIGO_PACKET_FLAG_SHORTENED 1
```

If the bit with **weight 1** is set, the packet was truncated because the internal FIFO was full. Less than the requested number of samples have been written due to the full FIFO.

```
#define NDIGO_PACKET_FLAG_PACKETS LOST 2
```

If the bit with **weight 2** is set, there are lost triggers immediately preceding this packet due to insufficient DMA buffers. The DMA controller has discarded packets due to full host buffer.

```
#define NDIGO_PACKET_FLAG_OVERFLOW 4
```

If the bit with **weight 4** is set, the packet contains ADC sample overflows.

```
#define NDIGO_PACKET_FLAG_TRIGGER MISSED 8
```

If the bit with **weight 8** is set, there are lost triggers immediately preceding this packet due to insufficient buffers. The trigger unit has discarded packets due to full FIFO.

```
#define NDIGO_PACKET_FLAG_DMA FIFO FULL 16
```

If the bit with **weight 16** is set, the internal DMA FIFO was full. Triggers only got lost if a subsequent package has the bit with **weight 8** set.

```
#define NDIGO_PACKET_FLAG_HOST_BUFFER_FULL 32
```

If the bit with **weight 32** is set, the host buffer was full. Triggers only got lost if a subsequent package has the bit with **weight 8** set.

```
#define NDIGO_PACKET_FLAG_TDC_NO_EDGE 64
```

If the bit with **weight 64** is set, the packet from the TDC does not contain valid data and the timestamp is not corrected. No valid edge was found in TDC packet.

unsigned int length

Number of **64-bit** elements (each containing 4 samples) in the data array if **type < 128**.

If **type = 128** this is the pattern of trigger sources that were active in the clock cycle given by the timestamp. Bits are set according to the trigger sources, i.e. **bit 0** is set if **trigger A0** was active, **bit 29** is set if **trigger BUS3 PE** was active. Use the **NDIGO_TRIGGER_SOURCE_*** defines to check for the bits set.

unsigned __int64 timestamp

ADC channels **A** to **D**: Timestamp of the last word in the packet in ps.

TDC: Timestamp of the trigger event (falling edge) on the TDC channel in ps.
When **ndigo_process_tdc_packet()** is called once on the packet the timestamp is replaced with the precise timestamp for the edge.

Timestamp channel: Timestamp of the trigger event in ps.

unsigned __int64 data[]

Sample data. For the **Ndigo5G** each **64 bit** word contains four **16 bit** signed words from the ADC. The user can cast the array to **short*** to directly operate on the sample data.

5.0 C-Example

```
1 #include "Ndigo_interface.h"
2 #include <stdio.h>
3 #include <stdlib.h>
4
5 int main(int argc, char* argv[])
6 {
7     ndigo_init_parameters params;
8     ndigo_get_default_init_parameters(&params);
9
10    params.card_index = 0;
11    params.buffer_size[0] = 1<<23;
12    params.drive_external_clock = true;
13    params.is_slave = false;
14    params.use_external_clock = false;
15
16    int error_code;
17    const char*error_message;
18    ndigo_device* ndgo = ndigo_init(&params, &error_code, &error_message);
19    if( error_code != NDIGO_OK ) {
20        printf("\nError %d: %s\n", error_code, error_message);
21        exit(-1);
22    }
23
24    ndigo_configuration config;
25    ndigo_get_default_configuration(ndgo, &config);
26    config.adc_mode = NDIGO_ADC_MODE_ABCD;
27
28    // disable unused trigger blocks
29    config.trigger_block[1].enabled = false;
30    config.trigger_block[2].enabled = false;
31    config.trigger_block[3].enabled = false;
32    config.trigger_block[4].enabled = false;
33
34    // configure trigger block 0
35    config.trigger_block[0].enabled = true;
36    config.trigger_block[0].minimum_free_packets = 1.0;
37    config.trigger_block[0].precursor = 0;
38    config.trigger_block[0].retrigger = 0;
39
40    config.trigger_block[0].sources = NDIGO_TRIGGER_SOURCE_A0;
41    config.trigger_block[0].length = 16;
42    config.trigger_block[0].gates = NDIGO_TRIGGER_GATE_NONE;
43
44    config.analog_offset[0] = 0.1;
45
46    config.trigger[NDIGO_TRIGGER_A0].edge = true;
47    config.trigger[NDIGO_TRIGGER_A0].rising = false;
48    config.trigger[NDIGO_TRIGGER_A0].threshold = 0;
```

```

49
50 if( ndigo_configure(ndgo, &config) != NDIGO_OK ){
51     printf("\nFatal configuration error. Aborting...\n");
52     exit(-1);
53 }
54
55 ndigo_start_capture(ndgo);
56
57 // counts the number of packets received
58 int count = 0;
59
60 while( count < 10 ){
61     ndigo_read_in in;
62     // Do not wait for data
63     // (if set to 1 the ndigo_acknowledge function has to be removed)
64     in.acknowledge_last_read = 0;
65     ndigo_read_out out;
66     int result = ndigo_read(ndgo, &in, &out);
67     if( !result ){
68         // buffer received with one or more packets
69         ndigo_packet *packet = out.first_packet;
70         while( packet <= out.last_packet ){
71             int length = 0;
72             if( !(packet->type & NDIGO_PACKET_TYPE_TIMESTAMP_ONLY) )
73                 length = packet->length;
74
75             printf("Card %02x, Channel %02x, Flags %02x, Length %6d, Timestamp
76                 %llu \n", packet->card, packet->channel, packet->flags,
77                 length, packet->timestamp);
78             if( !(packet->type & NDIGO_PACKET_TYPE_TIMESTAMP_ONLY) ){
79                 short* data = (short*) packet->data;
80                 for( inti = 0; i < packet->length * 4; i++ )
81                     printf("%6d, ", *(data++));
82                 printf("\n\n");
83             }
84             // current packet pointer is invalid after call to ndigo_acknowledge
85             ndigo_packet *next_packet = ndigo_next_packet(packet);
86             ndigo_acknowledge(ndgo, packet);
87             packet = next_packet;
88             count++;
89         }
90     }
91     ndigo_close(ndgo);
92     return 0;
93 }

```

6.0 Technical Data

- Input Passband: **4.5MHz** to **3000MHz**.
- Power Requirements: **25W**
- Mechanical Dimensions: **170mm x 106mm**
- Throughput: **800MByte/s** on PCIe x4

6.1 Digitizer Characteristics

Each board is tested against the values listed in the **Min** column. "Typical" is the mean value of the first 10 boards produced.

6.1.1 1-Channel-Mode (5Gsps)

Symbol	Parameter	Min	Typical	Max	Units
THD1	Total Harmonic Distortion	56	60		dB
SNR1	Signal to Noise Ratio	47	49		dB
SFDR _{incl} 1	Spurious Free Dynamic Range (including Harmonics)	55	59		dB
SFDR _{excl} 1	Spurious Free Dynamic Range (excluding Harmonics)	55	60		dB
SINAD1	Signal-to-Interference Ratio including Noise and Distortion	47	48		dB
ENOB1	Effective Number of Bits	7,5	7,7		

6.1.2 2-Channel-Mode (2.5 Gsps)

Symbol	Parameter	Min	Typical	Max	Units
THD2	Total Harmonic Distortion	56	60		dB
SNR2	Signal to Noise Ratio	49	51		dB
SFDR _{incl} 2	Spurious Free Dynamic Range (including Harmonics)	58	60		dB
SFDR _{excl} 2	Spurious Free Dynamic Range (excluding Harmonics)	58	61		dB
SINAD2	Signal-to-Interference Ratio including Noise and Distortion	49	50		dB
ENOB2	Effective Number of Bits	7,8	8,1		

6.1.3 4-Channel-Mode (1.25 Gsps)

Symbol	Parameter	Min	Typical	Max	Units
THD4	Total Harmonic Distortion	56	60		dB
SNR4	Signal to Noise Ratio	49	51		dB
SFDR _{incl} 4	Spurious Free Dynamic Range (including Harmonics)	58	60		dB
SFDR _{excl} 4	Spurious Free Dynamic Range (excluding Harmonics)	68	73		dB
SINAD4	Signal-to-Interference Ratio including Noise and Distortion	49	51		dB
ENOB4	Effective Number of Bits	7,9	8,1		

6.2 Electrical Characteristics

6.2.1 Oscillator

The **Ndigo5G** uses an OCXO oscillator with **25ppb** stability. After power up, the oscillator needs to run for **10 minutes** to reach this stability.

6.2.2 Environmental Conditions for Operation

The board is designed to be operated under the following conditions:

Symbol	Parameter	Min	Typical	Max	Units
T	ambient temperature	5		40	°C
RH	relative humidity at 31°C	20		75	%

6.2.3 Environmental Conditions for Storage

The board is designed to be operated under the following conditions:

Symbol	Parameter	Min	Typical	Max	Units
T	ambient temperature	-30		60	°C
RH	relative humidity at 31°C	10		70	%

6.2.4 Power Supply

Symbol	Parameter	Min	Typical	Max	Units
I	PCIe 3,3V rail power consumption			4	mA
VCC	PCIe 3,3V rail power supply	3,1	3,3	3,6	V
I	PCIe 12V rail power consumption			2,1	A
VCC	PCIe 12V rail power supply	11,1	12	12,9	V
I	PCIe 3,3VAux rail power consumption		0		A
VCC	PCIe 3,3VAux rail power supply		3,3		V

6.2.5 Analog Inputs

AC coupled single-ended analog inputs (standard version):

Symbol	Parameter	Min	Typical	Max	Units
V_{p-p}	Peak to peak input voltage			0,5	V
Z_p	input impedance		50		Ω
	Analog offset	-0,25		0,25	V

AC coupled differential analog inputs:

Symbol	Parameter	Min	Typical	Max	Units
V_{com}	Input common mode	-4		6	V
V_{p-p}	Differential input Voltage	-125		125	mV
Z_p	input impedance		100		Ω
	Analog offset	-0,25		+0,25	V

6.3 Information Required by DIN EN 61010-1

6.3.1 Manufacturer

The **Ndigo5G** is a product of:

cronologic GmbH & Co. KG
 Jahnstraße 49
 60318 Frankfurt

HRA 42869 beim Amtsgericht Frankfurt/M
 VAT-ID: DE235184378

6.3.2 Intended Use and System Integration

The devices are not ready to use as delivered by cronologic. It requires the development of specialized software to fulfill the application of the end user. The device is provided to system integrators to be built into measurement systems that are distributed to end users. These systems usually consist of a the **Ndigo5G**, a main board, a case, application software and possible additional electronics to attach the system to some type of detector. They might also be integrated with the detector.

The **Ndigo5G** is designed to comply with **DIN EN 61326-1** when operated on a PCIe compliant main board housed in a properly shielded enclosure. When operated in a closed standard compliant PC enclosure the device does not pose any hazards as defined by **EN 61010-1**.

Radiated emissions, noise immunity and safety highly depend on the quality of the enclosure. It is the responsibility of the system integrator to ensure that the assembled system is compliant to applicable standards of the country that the system is operated in, especially with regards to user safety and electromagnetic interference. Compliance was only tested for attached cables shorter than **3m**.

When handling the board, adequate measures have to be taken to protect the circuits against electrostatic discharge (ESD). All power supplied to the system must be turned off before installing the board.

6.3.3 Cooling

The **Ndigo5G** in its base configuration has passive cooling that requires a certain amount of air flow. If the case design can't provide enough air flow to the board, a slot cooler like Zalman ZM-SC100 can be placed next to the board. Active cooling is also available as an option to the board.

6.3.4 Environmental Conditions

See [Section 6.2.2](#) and [Section 6.2.3](#).

6.3.5 Inputs

All inputs are AC coupled. The inputs have very high input bandwidth requirements and therefore there are no circuits that provide over voltage protection for these signals. Any voltage on the inputs above **5V** or below **-5V** relative to the voltage of the slot cover can result in permanent damage to the board.

6.3.6 Recycling

cronologic is registered with the "Stiftung Elektro-Altgeräte Register" as a manufacturer of electronic systems with **Registration ID DE 77895909**.

The **Ndigo5G** belongs to **category 9**, **"Überwachungs und Kontrollinstrumente" für ausschließlich gewerbliche Nutzung**. The last owner of a **Ndigo5G** must recycle it, treat the board in compliance with **§11** and **§12** of the German ElektroG, or return it to the [manufacturer's address](#) listed on page 48.

7.0 Revision History

7.1 Firmware

Revision	Date	Comments
1.4865	2015-07-28	Internal optimizations
1.4824	2015-02-27	Fixed PCIe link training issues

7.2 Driver & Applications

Revision	Date	Comments
1.4.3	2019-10-21	Fixed a card initialization error in x64 32 mode
1.4.0	2019-06-04	Added Windows 10 support
1.3.0	2017-06-08	NdigoScope application now supports Ndigo250M-14

7.3 User Guide

Revision	Date	Comments
1.1.0	2019-08-27	API clarifications