

Visible Wavelength Extension for Femtosecond IR OPOs

Fully-Automated Second Harmonic Generator Tunable across 495 - 775 nm

ORIATM VIS



KEY FEATURES

- Highest power with >400 mW at the peak of the tuning range.
- Four output ports: 1) 990 - 1550 nm at full power, 2) 495 - 775 nm, 3) 1680 - 4000 nm, and 4) 990 - 1550 nm undepleted.
- Excellent beam pointing stability with TEM₀₀ spatial quality.
- Hands-free operation with a dedicated control software. Control drivers available.
- Compatible with most commercial femtosecond sources tunable across 990 - 1550 nm.

APPLICATIONS

- Time-Resolved Spectroscopy.
- Single-Molecule Spectroscopy.
- Pump-Probe Experiments.
- CARS and Raman Microscopy.
- Nanophotonics.

TUNE YOUR WAVELENGTH

Broadly Tunable Laser Systems for Science & Technology

Description

Broad tuning in the visible spectrum is now possible with the Oria VIS, a wavelength extension unit for most commercial femtosecond IR OPOs. This sophisticated second harmonic generation (SHG) module converts the IR spectrum of a femtosecond IR OPO (990 - 1550 nm) into the visible range (495 - 775 nm) in a practical and easy-to-use architecture.

The Oria VIS features the highest efficiency in its class, providing more than 40% conversion and 400 mW at the peak of the tuning range. As a result, output powers of more than 400 mW can be achieved when pumped by 1 W femtosecond pulses in the IR. High peak-to-peak power stability and excellent beam pointing across the complete spectral range make the Oria VIS a convenient tool for a range of scientific applications, including time-resolved spectroscopy and quantum optics.

Designed for pick-and-place installation, Oria VIS ensures virtually maintenance-free operation and highest usability since it does not require manual alignment, being exclusively controlled by a PC. Control drivers are also available.

Specifications⁽¹⁾

Output Characteristics	Oria VIS
Tuning range	495 - 775 nm
Output power ⁽²⁾	> 400 mW
Pulse width ⁽³⁾	< 180 fs
Beam diameter at 525 nm	2.5 mm
Beam divergence	< 1 mrad
Beam displacement with wavelength	< 2.5 μm
Spatial mode	TEM ₀₀
Polarization	Vertical
Repetition rate	80 MHz
Size (W x L x H)	568.0 x 366.5 x 189.2 mm (22.4 x 14.4 x 7.5 inch)

Notes: (1) Specifications are subject to change without notice. (2) At the peak of the tuning range, when pumped by Oria™ IR OPO. (3) When pumped with Oria™ IR OPO.

Oria IR and Oria VIS

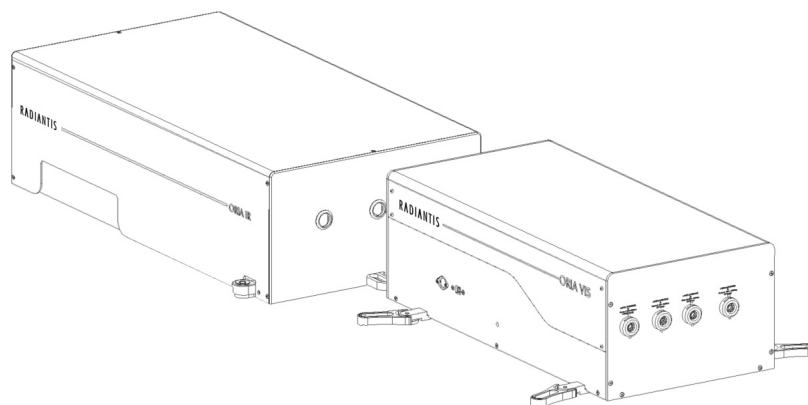

Oria Vis Wavelength Coverage

Complete Spectral Coverage of Ti:Sapphire pump, Oria IR XT, and Oria VIS

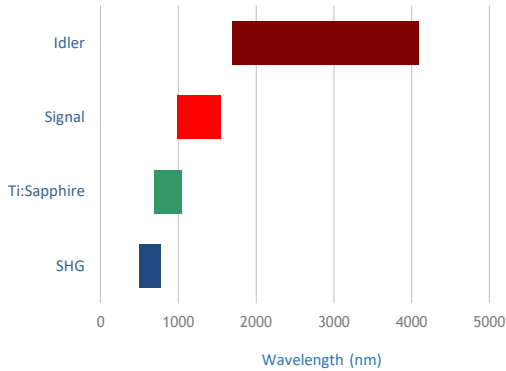

The Oria VIS includes four output ports which deliver 1) the OPO signal (990 - 1550 nm), 2) the SHG of the OPO signal (495 - 775 nm), 3) the OPO idler (1680 - 4000 nm), and 4) the depleted OPO signal (990 - 1550 nm). It incorporates a pump bypass which enables the selection of 100% of the OPO signal and idler (with no SHG of the signal) or 100% of the SHG of the signal (simultaneously with the undepleted OPO signal and 100% of the idler).

Typical Oria VIS Tuning Curve

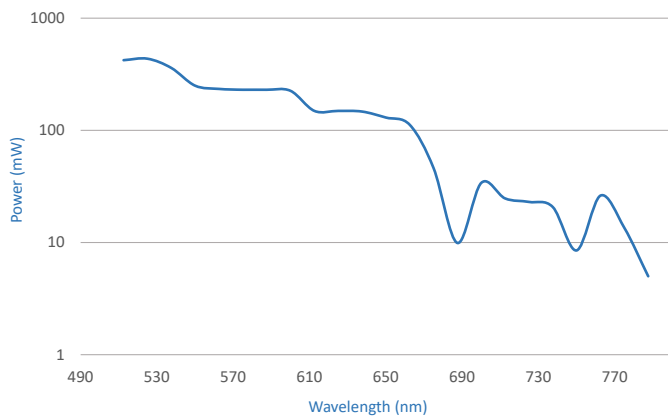

Diamond Plot

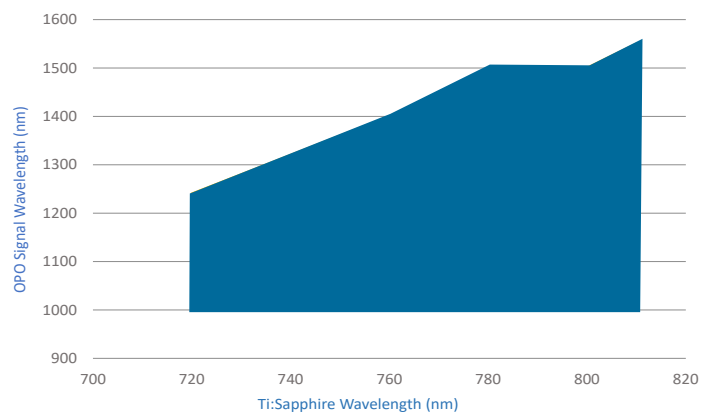

Dimensions

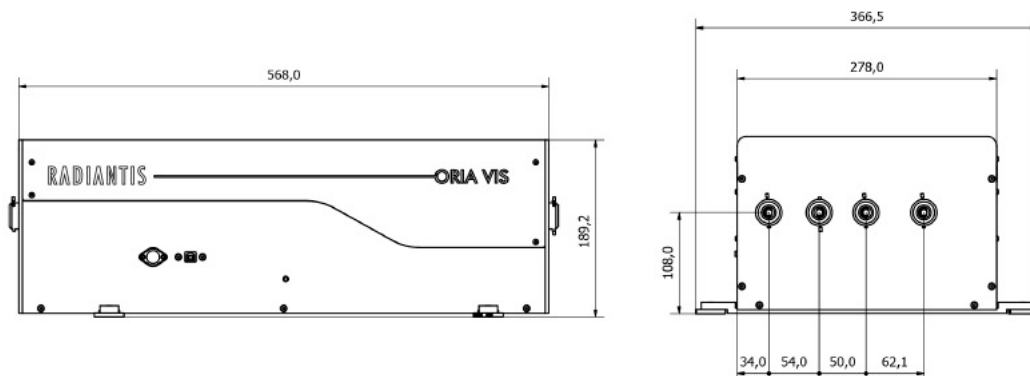

Notes: Dimensions in mm