

xiRAY | X-ray CMOS and sCMOS cameras

See the invisible

preliminary

上海昊量光电设备有限公司Aunion Tech Co., Ltd

www.auniontech.com

Tel: +86-21-51083793

负责人电话: 13167190195 李臣阳

Table of Contents

1.	General description	4
2.	Camera model overview	5
2.1.	X-ray cameras - support page	5
3.	Camera details	6
3.1.	MJ150XR-GP-FA-xx	6
3.1.1.	Specifications	6
3.1.2.	Drawings.....	7
3.2.	MJ150XR-GP-TP2:1-GO	8
3.2.1.	Specifications	8
3.2.2.	Drawings.....	9
3.3.	MX510XG-GP-FA-GO.....	10
3.3.1.	Specifications	10
3.3.2.	Drawings.....	11
3.4.	MX510XG-GP-TP2:1-GO.....	12
3.4.1.	Specifications	12
3.4.2.	Drawings.....	13
3.5.	MX377XR-GP-F1-FA-GO.....	14
3.5.1.	Specifications	14
3.5.2.	Drawings.....	15
3.5.2.1.	Camera structure	15
3.5.2.2.	Fan cooling, standard MTP connector orientation	15
3.5.2.3.	Fan cooling, vertical MTP connector orientation.....	16
3.5.2.4.	Water cooling, standard MTP connector orientation	17
3.5.2.5.	Water cooling, vertical MTP connector orientation	18
3.6.	MX610XR-SY-FA-xx.....	19
3.6.1.	Specifications	19
3.6.2.	Drawings.....	20
3.6.3.	Drawing Firefly rear module	21
3.6.3.1.	Cooling options	21
3.6.4.	Optional MTP-adapter	22
3.6.4.1.	Cooling options	22
3.7.	MX610XR-SY-X4G3-TP21-xx	23
3.7.1.	Specifications	23
3.7.1.	Drawings.....	24
3.7.1.	Drawing Firefly rear module	25
3.7.1.1.	Cooling options	25
3.7.2.	Optional MTP-adapter	26
3.7.2.1.	Cooling options	26
3.8.	MX1510XR-SY-FA-GO	27
3.8.1.	Specifications	27
3.8.2.	Drawings.....	28
3.8.3.	Drawing Firefly rear module	30
3.8.3.1.	Cooling options	30
3.8.4.	Optional MTP-adapter	31

3.8.4.1. Cooling options	31
4. Sample images.....	32
5. Compatibility and contact information	33
6. Revision history	34

1. General description

xiRAY is a family of X-ray CMOS and sCMOS cameras for extraordinary X-ray imaging

Small and compact

The xiRay cameras use various high-resolution sensors with up to 151 MPixel, bonded to a fiber optic plate or fiber taper, coupled to a scintillator. This makes these cameras the ultimate solution for micro-tomography, medical applications and inspection such as homeland security, manufacturing and other demanding applications.

Optimized for highest image quality and sensitivity

The use of ultra-low noise sensor technology, coupled with moderate, active TEC cooling, provides superior sensitivity and image quality. All built into a full metal housing that guarantees stability and longevity.

Customizable

We will configure and build xiRay cameras exactly for your specific application requirements. The option set includes other sensors, interfaces, scintillators and housing designs.

2. Camera model overview

Model	Short description	Active image size [mm]	Resolution	ADC [bits]	FWC [ke-]	Readout noise [e-]	DR [dB]	FPS	Interface
MJ150XR-GP-FA-GO	GadOx:Eu, 10u, 2.5u grain 7-100 keV	21.5 x 12.6	5056 x 2968 15 MPix	2 x 12	17	1.5	82	17	USB3.1
MJ150XR-GP-FA-CSI	CSI, 150u 7-100 keV								
MJ150XR-GP-TP2:1-GO	GadOx, 10u, 2.5u grain, 2:1 taper optics 7-150 keV	43.0 x 25.2							
MX377XR-GP-F1-FA-GO	GadOx:Eu, 22u, 2.5u grain 7-100 keV	61.1 x 61.1	6144 x 6144 37.7 MPix	2 x 14	110	3	90	46	PCIe X4G3
MX510XG-GP-FA-GO	GadOx:Eu, 10u, 2.5u grain 7-100 keV	38.9 x 27.8	8464 x 6058 51 MPix	12	24	1.6	84	30	TB3 / PCIe X4G3
MX510XG-GP-TP2:1-GO	GadOx:Eu, 22u, 2.5u grain, 1.88:1 taper optics 7-150 keV	70.5 x 50.4							
MX610XR-SY-FA-GO	GadOx:Eu, 10u, 2.5u grain 7-100 keV	36 x 23.8	9568 x 6380 61 MPix	16	45	1.3	80	17.9	PCIe X4G3
MX610XR-SY-FA-CSI	CSI, 150u 7-100 keV								
MX610XR-SY-X4G3-TP21-GO	GadOx:Eu, 10u, 2.5u grain 7-150 keV								
MX610XR-SY-X4G3-TP21-CSI	CSI, 150u 7-150 keV								
MX1510XR-SY-FA-GO	GadOx:Eu, 10u, 2.5u grain 7-100 keV	60.3 x 47.9	14192 x 10640 151 MPix	16	50	3	78	6	PCIe X4G3

Notes:

- The camera models MX377XR-GP-F1-FA-GO, MX610XR-SY-FA-* and MX1510XR-SY-FA-GO are in an early development status.
- all other cameras are technical samples – please ask for details about the status

2.1. X-ray cameras - support page

Most recent info about XIMEA's X-ray cameras is available at <https://www.ximea.com/support/projects/standard-cameras/wiki/X-RAY>

3. Camera details

3.1. MJ150XR-GP-FA-xx

Cooled scientific USB3.1 X-ray sCMOS camera, 15MPix, 1:1 fiber optic plate
 Scientific CMOS sensor GPixel 5130 with Peltier TE Cooling

2 models with different scintillators are available:

- MJ150XR-GP-FA-GO: GadOx scintillator
- MJ150XR-GP-FA-CSI CSI scintillator not a standard product:: includes NRE or MOQ

3.1.1. Specifications

Active X-ray image size	21.5 x 12.6 mm ²
Effective pixel size	4.25 μm
Entrance windows	0.5mm Beryllium plate. Radiation hardened glass
Scintillator	GadOx: GadOx:Eu, 10μm thick, 2.5μm grain CSI: Cesium Iodide, 150μm thick
X-ray energy level	7 – 100 keV
Resolution	15 MPix, 5056 × 2968 pixels
Frame rates	17 Fps
Sensor model	Gpixel GSENSE5130
Sensor type	Scientific CMOS (sCMOS)
Sensor size	APS-C Format
Sensor active area	21.5 x 12.6 mm ² (24.9 mm diagonal)
Readout method	Global or Rolling shutter
Sensor pixel size	4.25 μm
Digitization	2 x 12 (16 Bit from API)
Data interface	USB 3.1 Type C
Dynamic range	77 dB / 82 dB (HDR in Rolling)
Full Well Capacity	18 000 e-
Readout noise typ.	1.5 e- (Rolling)
Signal to noise ratio	41.7 dB
I/O Ports	GPIO 1IN, 10UT, Serial Port
Power consumption	3.5 W - 16 W with Cooling
Weight	170 grams
Dimensions WxHxD	52 x 52 x 55 mm ³
Cooling	Up to -25°C (with Peltier TEC)

3.1.2. Drawings

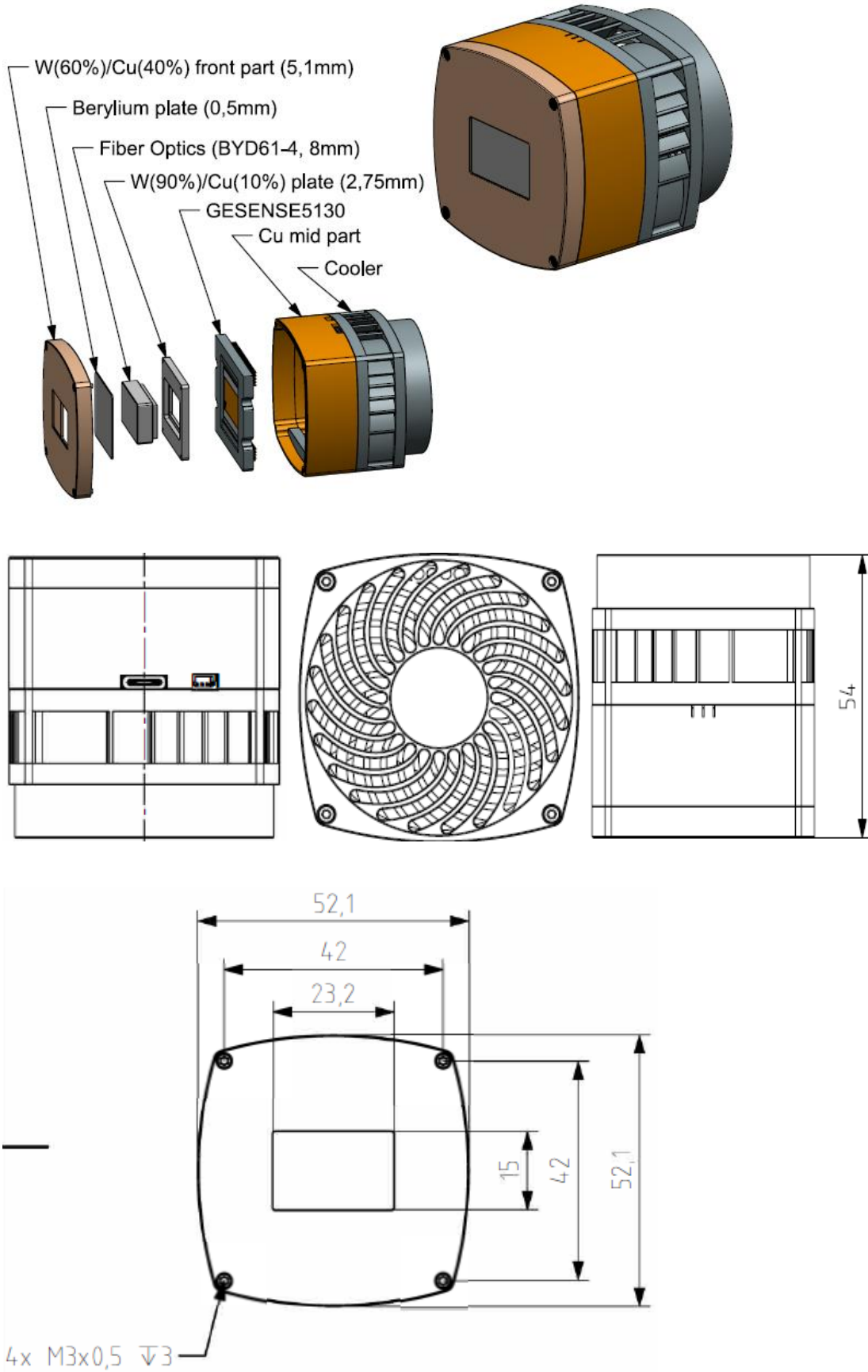

3.2. MJ150XR-GP-TP2:1-GO

Cooled scientific USB3.1 X-ray sCMOS camera, 15MPix, Magnification 2:1 tapered fiber optic plate, GadOx scintillator
Scientific CMOS GPixel 5130 with Peltier TE Cooling

3.2.1. Specifications

Active X-ray image size	43.0 x 25.2 mm ²
Effective pixel size	8.5 μm
Entrance windows	0.5mm Beryllium plate. Radiation hardened glass
Scintillator	GadOx:Eu, 22μm thick, 2.5μm grain
X-ray energy level	7 – 150 keV
Resolution	15 MPix, 5056 × 2968 pixels
Frame rates	17 Fps
Sensor model	Gpixel GSENSE5130
Sensor type	Scientific CMOS (sCMOS)
Sensor size	APS-C Format
Sensor active area	21.5 x 12.6 mm ² (24.9 mm diagonal)
Readout method	Global or Rolling shutter
Sensor pixel size	4.25 μm
Digitization	2 x 12 (16 Bit from API)
Data interface	USB 3.1 Type C
Dynamic range	77 dB / 82 dB (HDR in Rolling)
Full Well Capacity	18 000 e ⁻
Readout noise typ.	1.5 e ⁻ (Rolling)
Signal to noise ratio	41.7 dB
I/O Ports	GPIO 1IN, 1OUT, Serial Port
Power consumption	3.5 W - 16 W with Cooling
Weight	170 grams
Dimensions WxHxD	64 x 64 x 103 mm ³
Cooling	Up to -25°C (with Peltier TEC)

3.2.2. Drawings

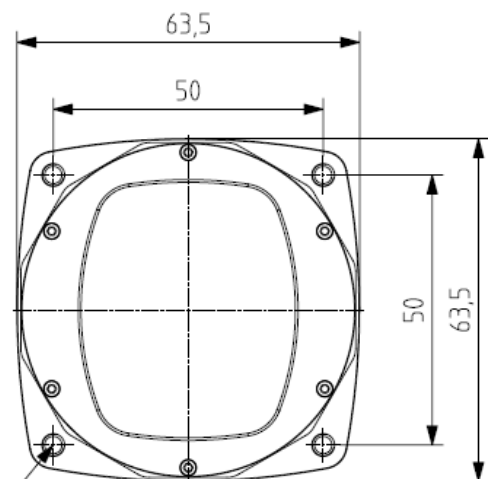
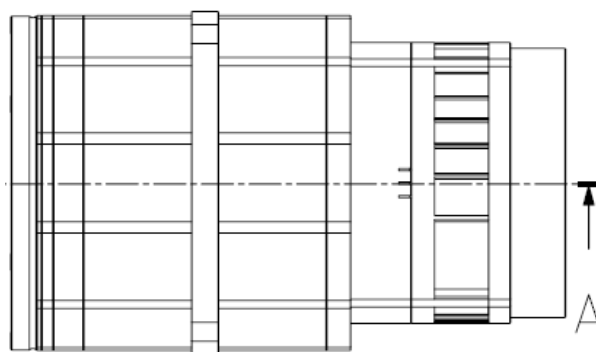
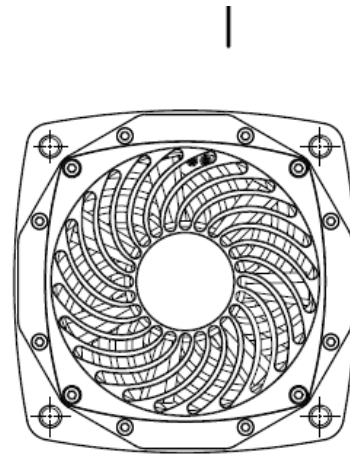
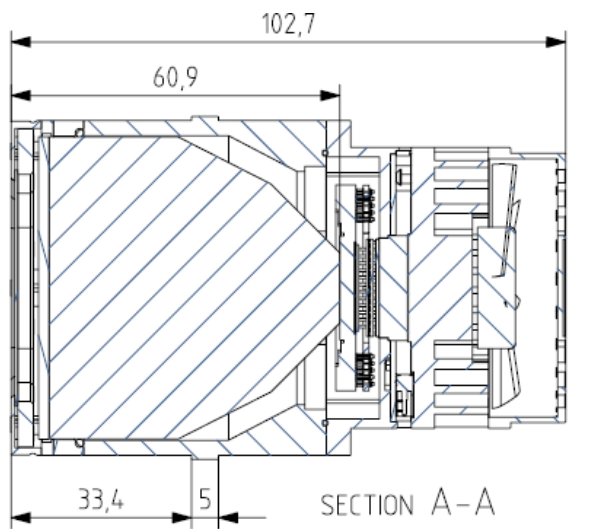
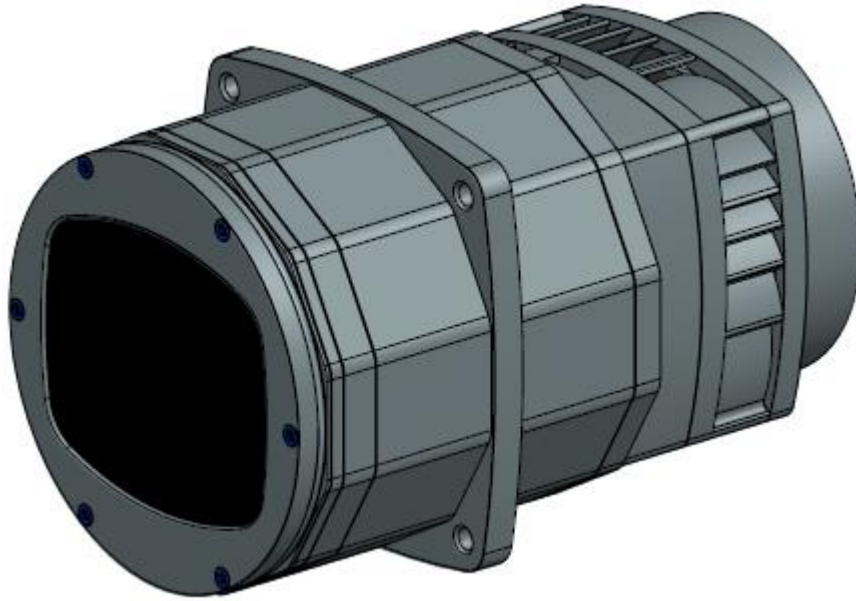

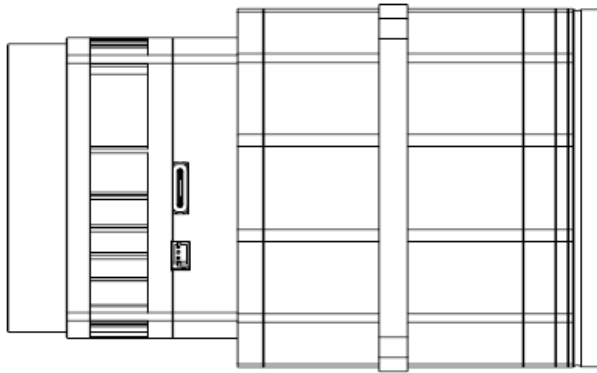

3.3. MX510XG-GP-FA-GO

Cooled scientific TB3/PCIe X-ray sCMOS camera, 51MP, 1:1 fiber optic plate, GadOx scintillator
CMOS sensor GPixel GMAX4651 grade 1 with Peltier TE Cooling

3.3.1. Specifications

Active X-ray image size	38,9 x 27.8 mm ²
Effective pixel size	4.6 μm
Entrance windows	Radiation hardened glass
Scintillator	GadOx:Eu, 10μm thick, 2.5μm grain
Fiber optic plate	Enhanced Statistical Extra-Mural Absorption
X-ray energy level	7 – 100 keV
Resolution	51 MPix, 8464 × 6058 pixels
Frame rates	30 Fps
Sensor model	Gpixel GMAX4651 grade 1
Sensor type	CMOS
Sensor size	Full frame 35mm
Sensor active area	38,9 x 27.8 mm ²
Readout method	Global shutter
Sensor pixel size	4.6 μm
Digitization	12 Bit
Data interface	Thunderbolt 3, PCIe Gen3 x4 FireFly
Dynamic range	84 dB (HDR) / 65 dB
Full Well Capacity	24 000 e ⁻ (HDR) / 18 000 e ⁻
On-Chip binning	1x1, 2x2, 4x4, 8x8
Dark current	6 e ⁻
Readout noise typ.	1.6 e ⁻ (HDR) / 9 e ⁻
Power consumption	3.5 W - 16 W with Cooling
Dimensions WxHxD	63 x 63 x 53 mm ³
Cooling	Up to -25°C (with Peltier TEC)

3.3.2. Drawings

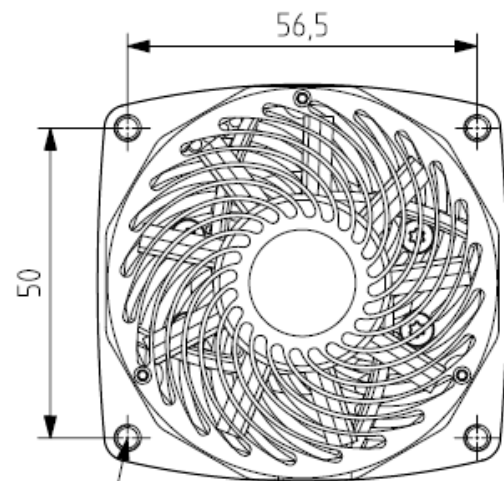
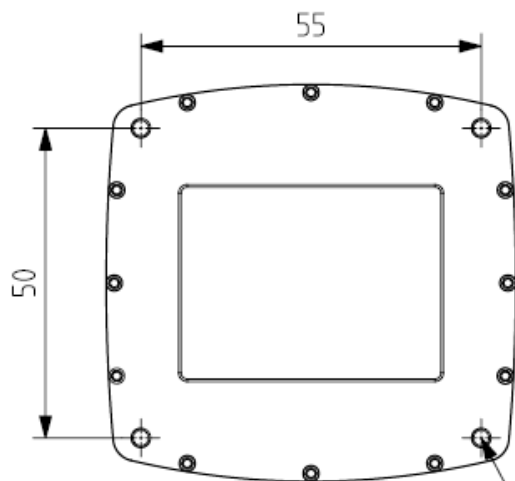
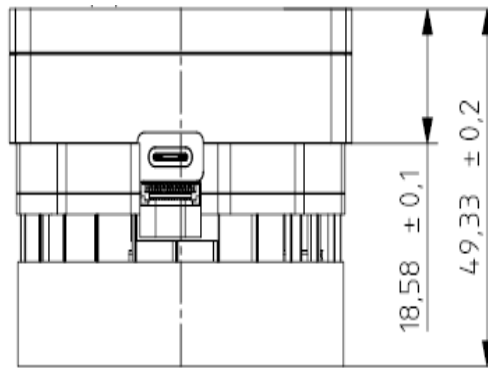
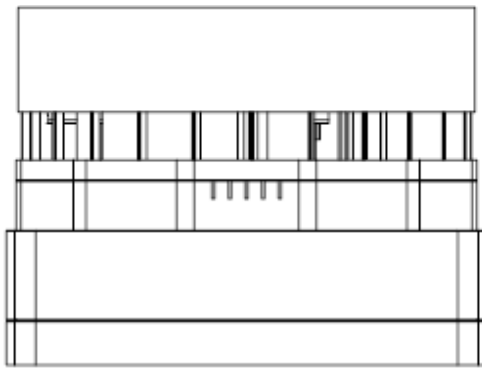
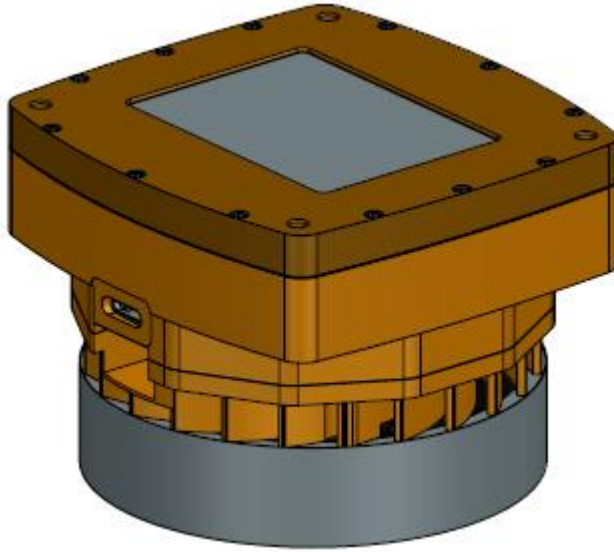

4x M3x0,5 ∇ 4

4x M4x0,7 ∇ 5,5

3.4. MX510XG-GP-TP2:1-GO

Cooled scientific TB3/PCIe X-ray sCMOS camera, 51MPix, 2:1 tapered fiber optic plate, GadOx scintillator
CMOS sensor Gpixel GMAX4651 grade 1 with Peltier TE Cooling

3.4.1. Specifications

Active X-ray image size	70.5 x 50.4 mm ²
Effective pixel size	8.5 μm
Entrance windows	Radiation hardened glass
Scintillator	GadOx:Eu, 22μm thick, 2.5μm grain
Fiber optic plate	Enhanced Statistical Extra-Mural Absorption
X-ray energy level	7 – 150 keV
Resolution	51 MPix, 8464 × 6058 pixels
Frame rates	30 Fps
Sensor model	Gpixel GMAX4651 grade 1
Sensor type	CMOS
Sensor size	Full frame 35mm
Sensor active area	38,9 x 27.8 mm ²
Readout method	Global shutter
Sensor pixel size	4.6 μm
Digitization	12 Bit
Data interface	Thunderbolt 3, PCIe Gen3 x4 FireFly
Dynamic range	84 dB (HDR) / 65 dB
Full Well Capacity	24 000 e- (HDR) / 18 000 e-
On-Chip binning	1x1, 2x2, 4x4, 8x8
Dark current	6 e-
Readout noise typ.	1.6 e- (HDR) / 9 e-
Power consumption	3.5 W - 16 W with Cooling
Dimensions WxHxD	63 x 63 x 53 mm ³
Cooling	Up to -25°C (with Peltier TEC)

3.4.2. Drawings

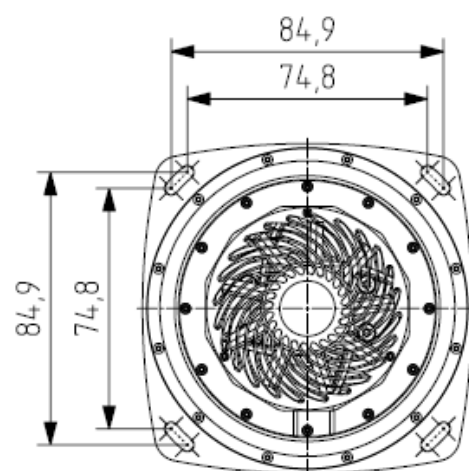
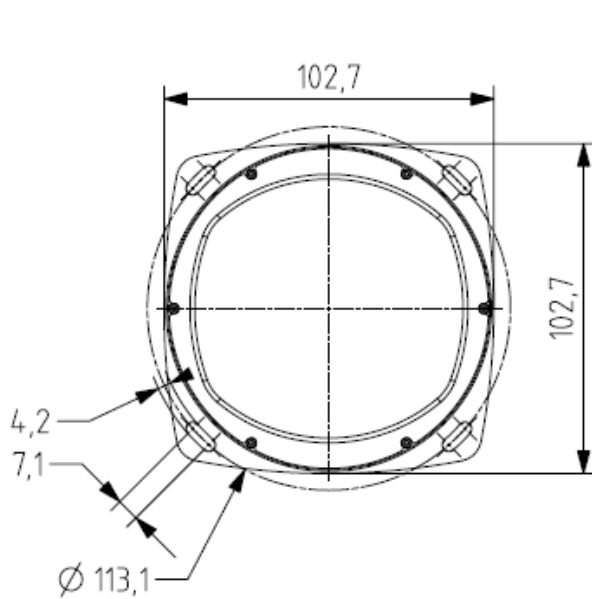
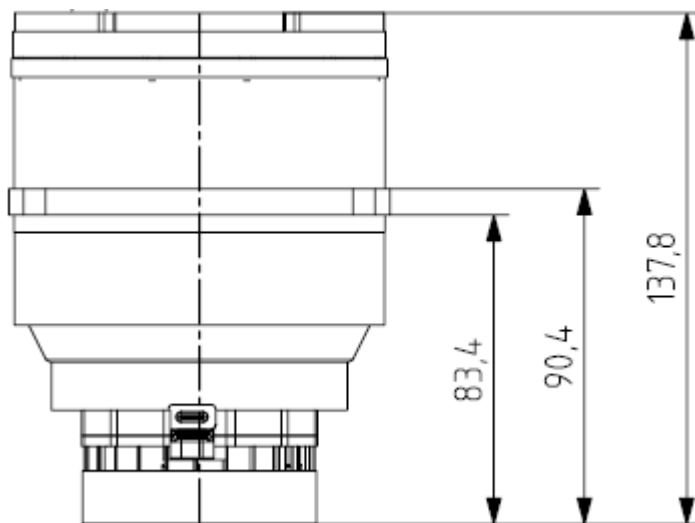
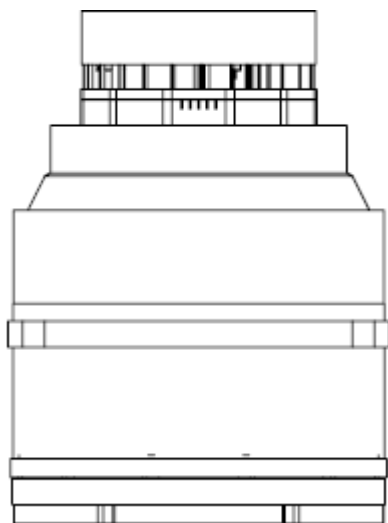
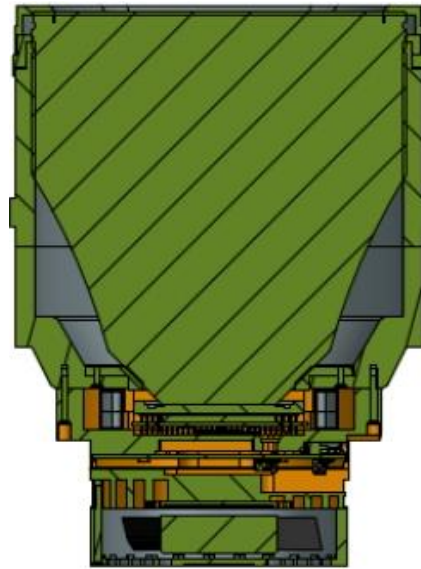
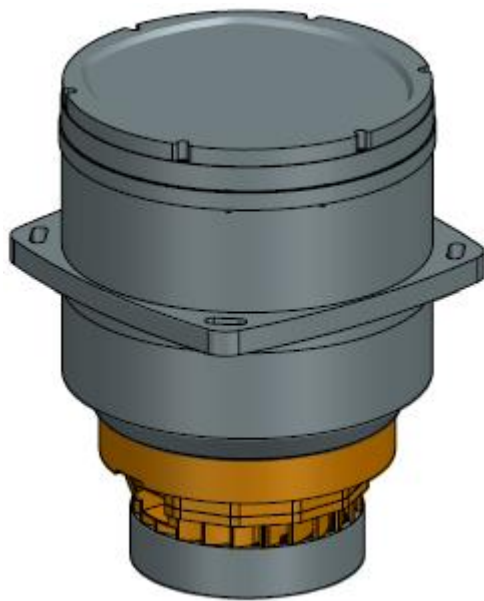

3.5. MX377XR-GP-F1-FA-GO

Cooled scientific PCIe X-ray sCMOS camera, 37.7MP, 1:1 fiber optic plate, GadOx scintillator
 Scientific CMOS GPixel 6060 FSI Grade 1 with Peltier TE Cooling

XIMEA offers four different models of this camera:

- - Water cooling or fan
- - MTP fiber optic connector in two different orientations

Please contact XIMEA Sales for details.

Early engineering samples available

3.5.1. Specifications

Active X-ray image size	61.4 x 61.4 mm ²
Effective pixel size	10 μm
Entrance windows	0.5mm Beryllium plate. Radiation hardened glass
Scintillator	GadOx:Eu, 22μm thick, 2.5μm grain
X-ray energy level	7 – 100 keV
Resolution	37.7 MPix, 6114 × 6114 pixels
Frame rates	46 FPS (12-bit STD mode)
Sensor model	Gpixel GSENSE6060 FSI
Sensor type	Scientific CMOS (sCMOS), Frontside illuminated
Sensor size	Medium format
Sensor active area	61.4 x 61.4 mm ²
Readout method	Rolling shutter
Sensor pixel size	10 μm
Digitization	2 x 12, 2 x 14 Bit
Data interface	PCIe Gen3 x4, fiber optics MTP connector
Dynamic range	90 dB (HDR mode)
Full Well Capacity	133 000 e-
Readout noise typ.	3 e-
Signal to noise ratio	51.7 dB
I/O Ports	GPIO 2IN, 2OUT
Power consumption	20 W - 80 W with Cooling
Dimensions WxHxD	83 x 110 x 76 mm ³
Cooling	Up to -25°C (with Water Cooling)

Notes:

- Dynamic range, Full Well Capacity, Readout noise and Signal to noise ratio are highly dependent on the sensor mode.

3.5.2. Drawings

3.5.2.1. Camera structure

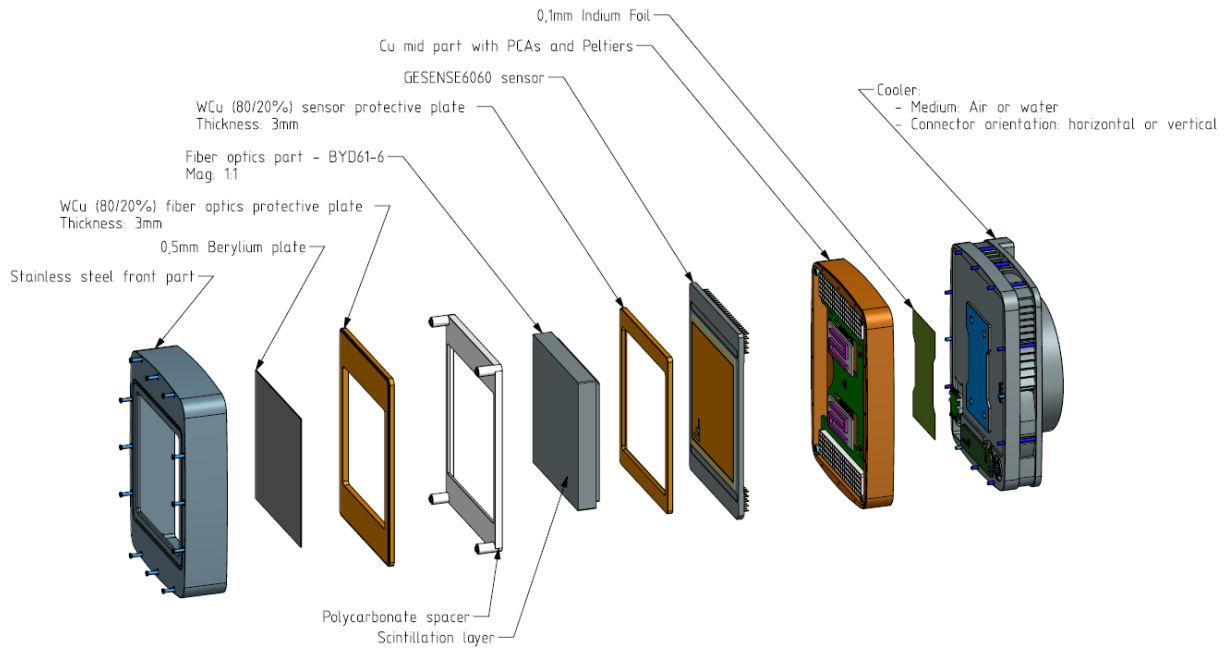

3.5.2.2. Fan cooling, standard MTP connector orientation

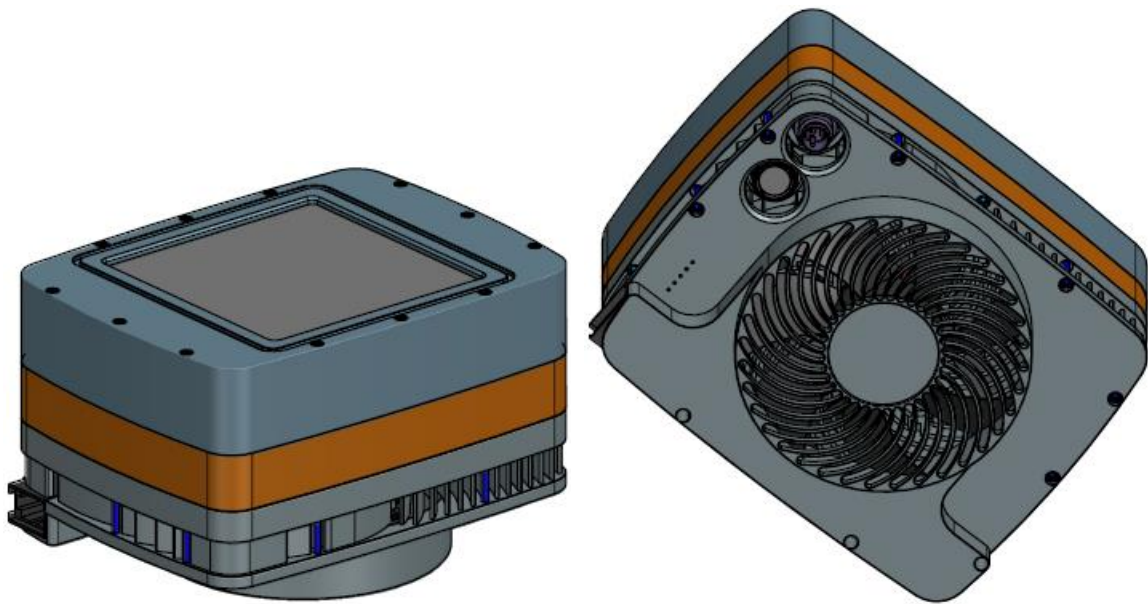

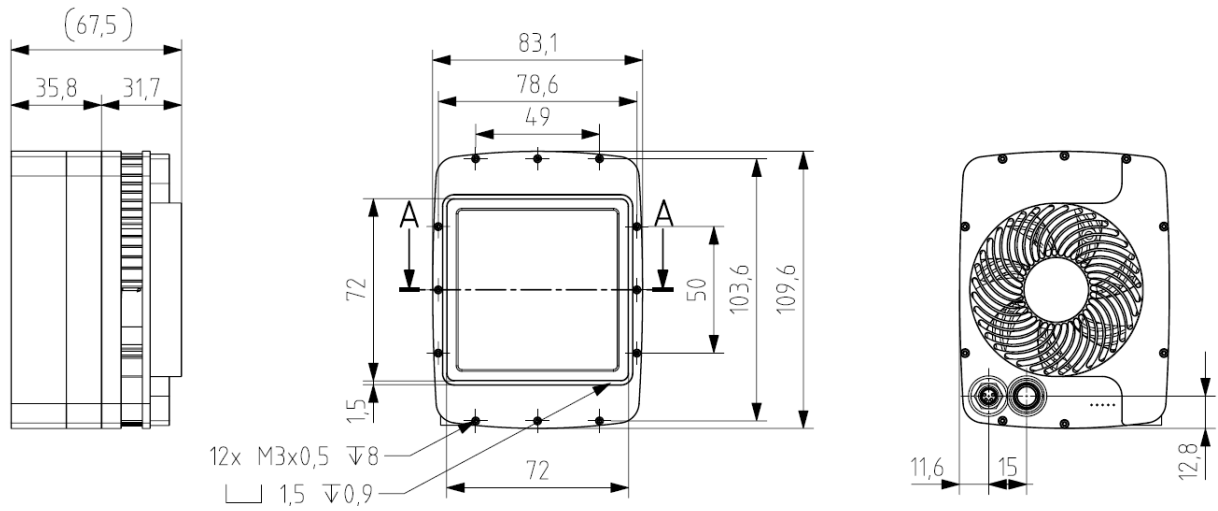

3.5.2.3. Fan cooling, vertical MTP connector orientation

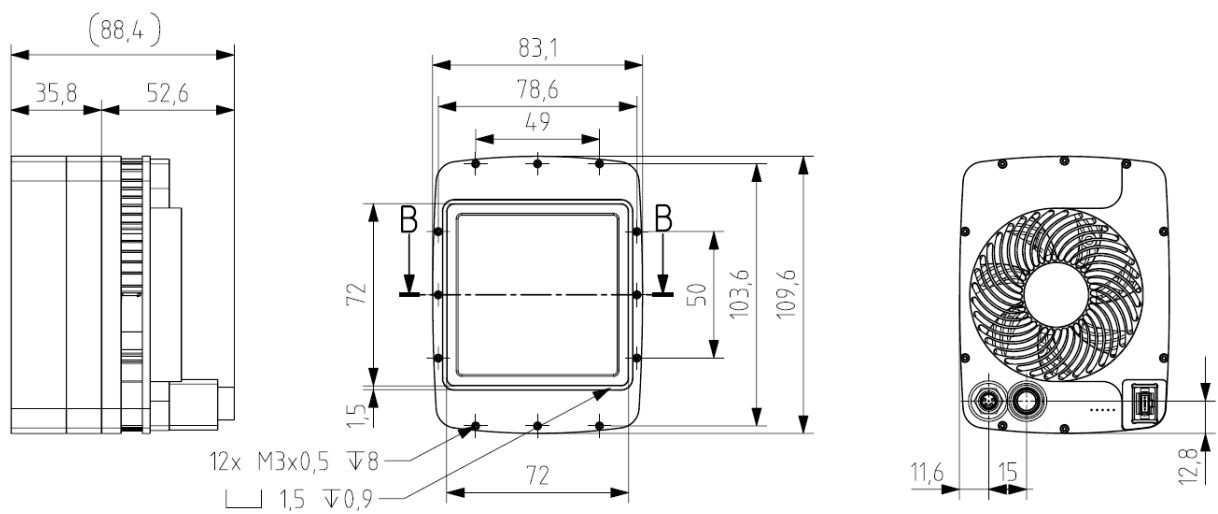
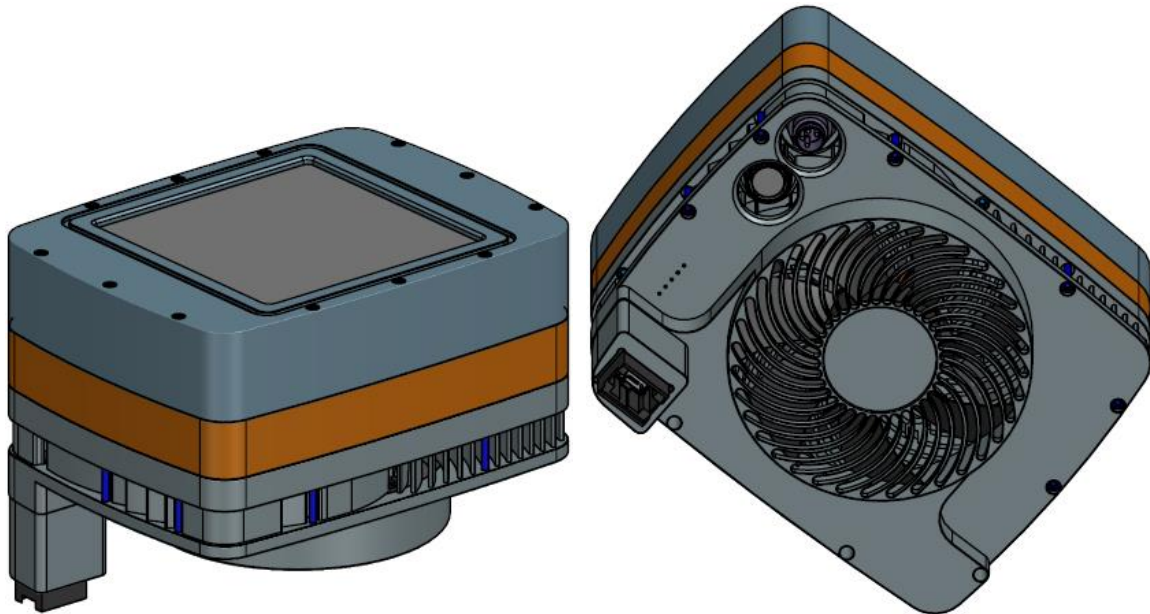

3.5.2.4. Water cooling, standard MTP connector orientation

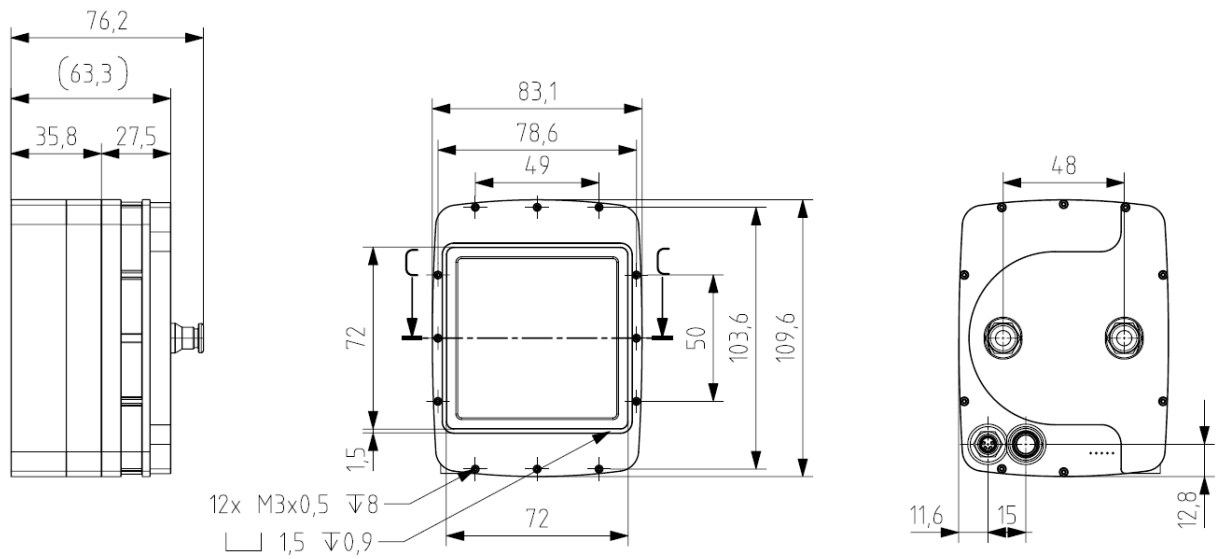
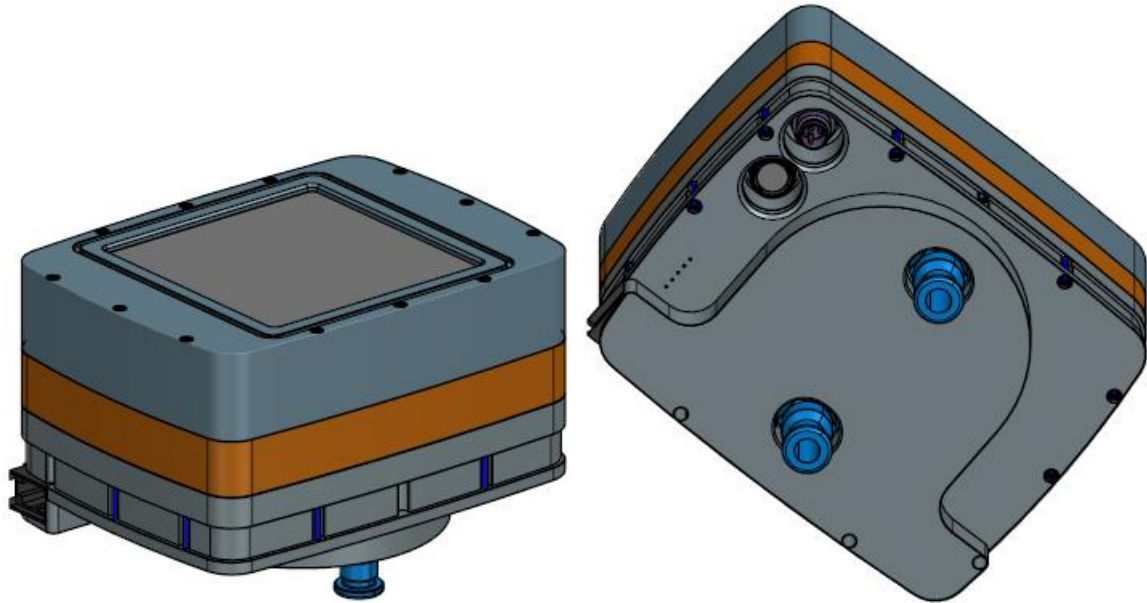

3.5.2.5. Water cooling, vertical MTP connector orientation

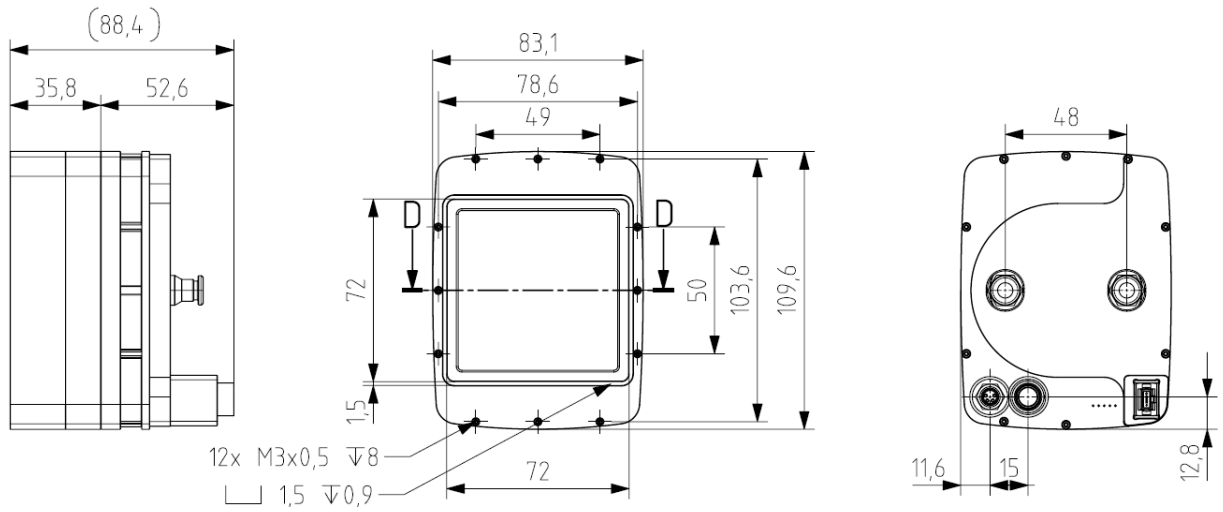
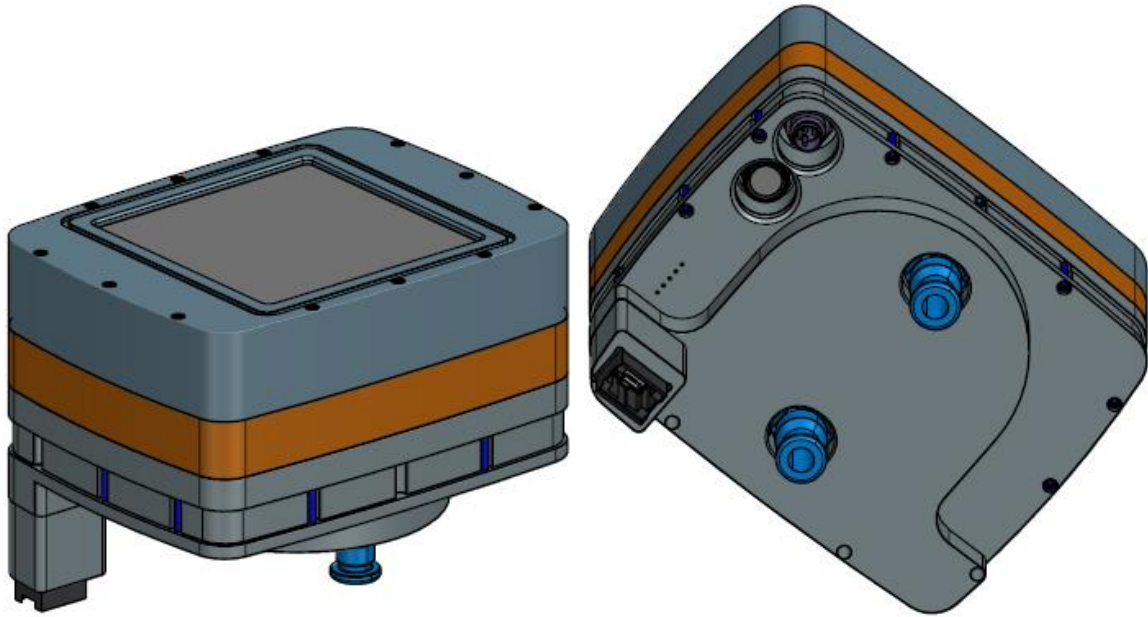

3.6. MX610XR-SY-FA-xx

Scientific PCIe X-ray CMOS camera, 61MP, 1:1 fiber optic plate,
SONY IMX455 CMOS

2 models with different scintillators are available:

- MX610XR-SY-FA-GO: GadOx scintillator
- MX610XR-SY-FA-CSI CSI scintillator

Sensor unit and electronics are spatially separated from each other and are connected by a ribbon cable. This allows the sensor unit to be cooled passively.

Early technical samples available. Please ask for available variants!

3.6.1. Specifications

Active X-ray image size	35.98 x 23.86 mm ²
Effective pixel size	3.76 μm
Entrance windows	0.5mm Beryllium plate. Radiation hardened glass
Scintillator	GadOx: GadOx:Eu, 10μm thick, 2.5μm grain CSI: Cesium Iodide, 150μm thick
X-ray energy level	7 – 100 keV
Resolution	61 MPix, 9568 x 6380 pixels
Frame rates	17.9 fps @ 12 bit, 3.98 fps @ 16 bit
Sensor model	SONY IMX455
Sensor type	CMOS, Backside illuminated
Sensor size	Full size
Sensor active area	35.98 x 23.86 mm ²
Readout method	Rolling shutter
Sensor pixel size	3,76 μm
Digitization	16 Bit
Data interface	PCIe Gen3 x4
Dynamic range	80 dB
Full Well Capacity	45 ke-
On-Chip binning	1x1, 2x2, 3x3
Readout noise typ.	1.3 e- (high gain modes)
Power consumption	15.4 W
Weight	450 grams (front part 210g, rear part 240g)
Dimensions WxHxD	57.3 x 48.3 x 19.7 mm ³ (sensor unit)

3.6.2. Drawings

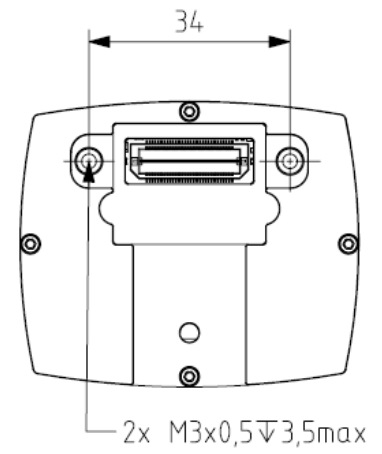
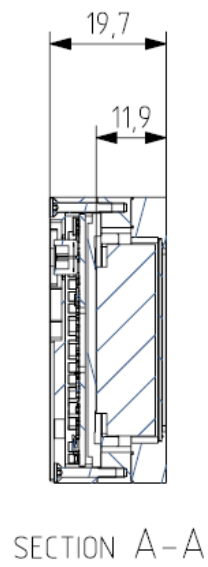
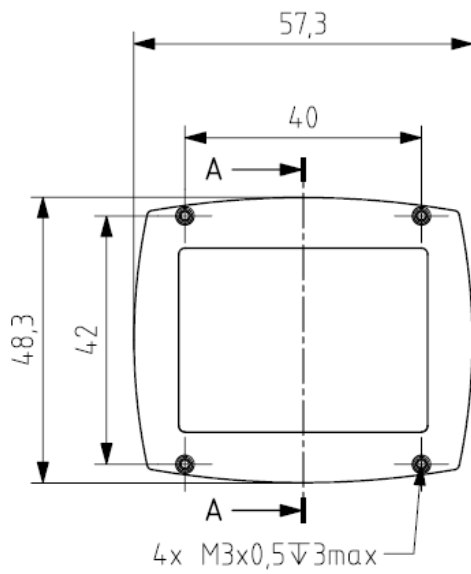
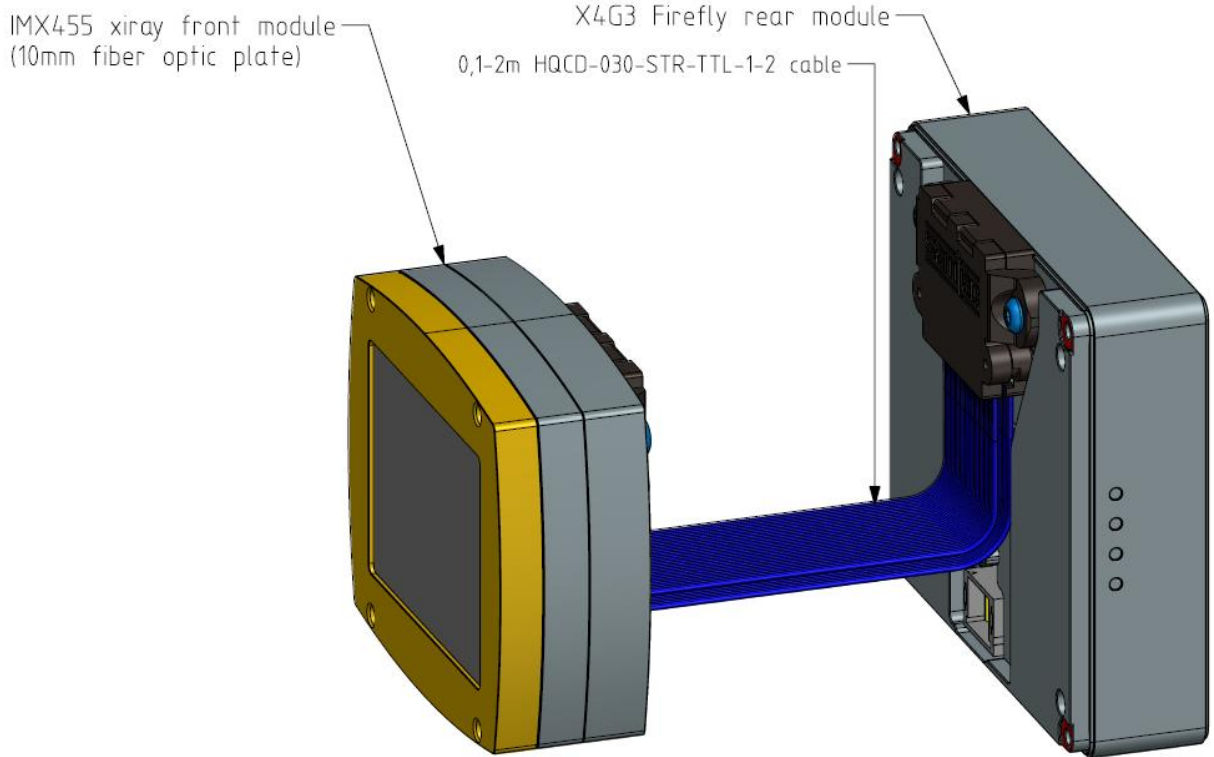

3.6.3. Drawing Firefly rear module

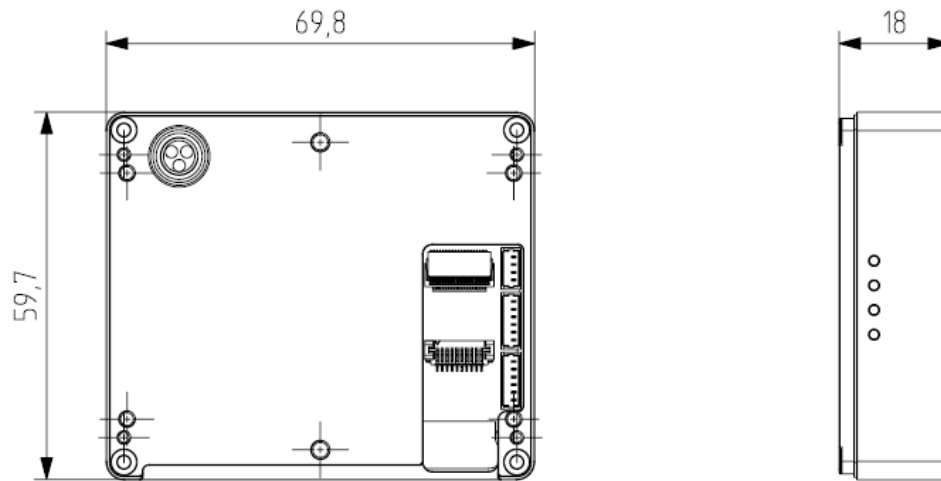

3.6.3.1. Cooling options

Air cooled heatsink option

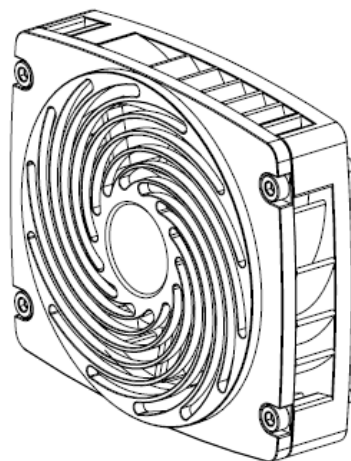

or

Water cooled heatsink option

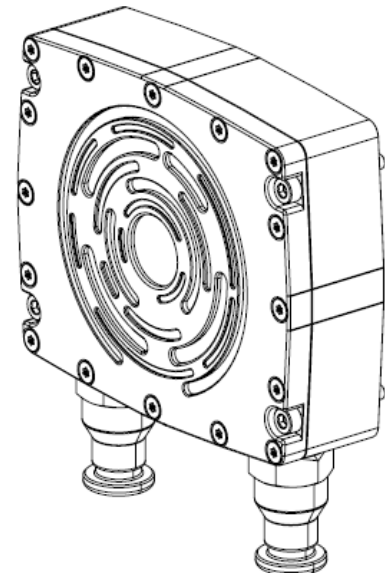

3.6.4. Optional MTP-adapter

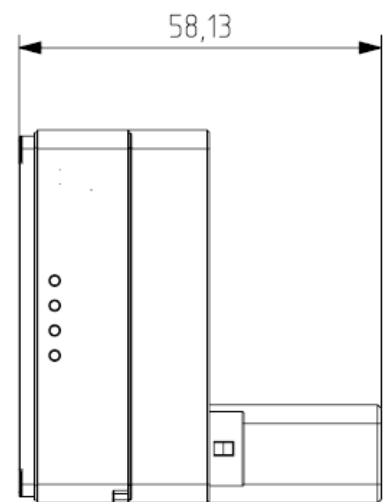
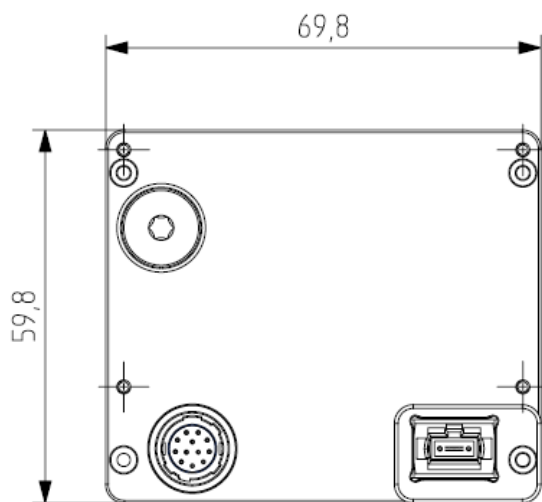
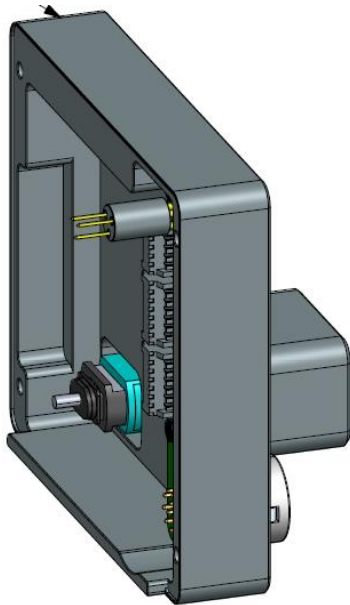

3.6.4.1. Cooling options

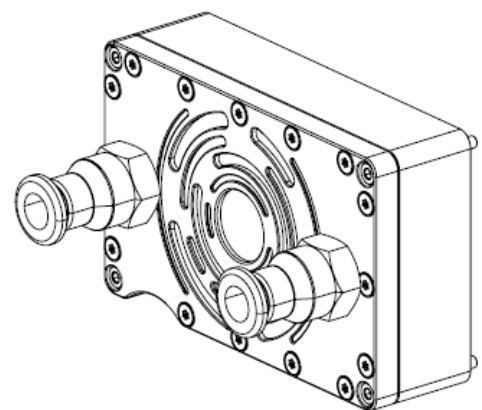
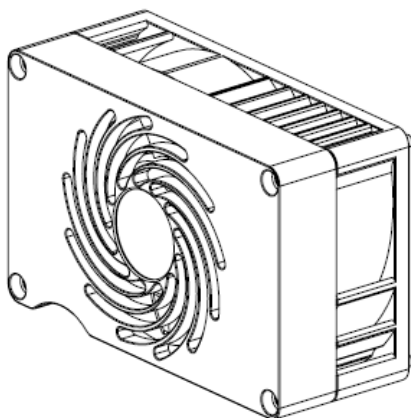

3.7. MX610XR-SY-X4G3-TP21-xx

Scientific PCIe X-ray CMOS camera, 61MP, 2:1 tapered fiber optic plate
SONY IMX455 CMOS

2 models with different scintillators are available:

- MX610XR-SY-X4G3-TP21-GO: GadOx scintillator not a standard product:: includes NRE or MOQ
- MX610XR-SY-X4G3-TP21-CSI CSI scintillator not a standard product:: includes NRE or MOQ

Sensor unit and electronics are spatially separated from each other and are connected by a ribbon cable. This allows the sensor unit to be cooled passively.

Early technical samples available. Please ask for available variants!

3.7.1. Specifications

Active X-ray image size	72 x 47.7 mm
Effective pixel size	7.52 μm
Entrance windows	0.5mm Beryllium plate. Radiation hardened glass
Scintillator	GadOx: GadOx:Eu, 10 μm thick, 2.5 μm grain CSI: Cesium Iodide, 150 μm thick
X-ray energy level	7 – 150 keV
Resolution	61 MPix, 9568 x 6380 pixels
Frame rates	17.9 fps @ 12 bit, 3.98 fps @ 16 bit
Sensor model	SONY IMX455
Sensor type	CMOS, Backside illuminated
Sensor size	Full size
Sensor active area	35.98 x 23.86 mm ²
Readout method	Rolling shutter
Sensor pixel size	3,76 μm
Digitization	16 Bit
Data interface	PCIe Gen3 x4
Dynamic range	80 dB
Full Well Capacity	45 ke-
On-Chip binning	1x1, 2x2, 3x3
Readout noise typ.	1.3 e- (high gain modes)
Power consumption	15.4 W
Weight	1.968 grams (front part 1.728g, rear part 240g)
Dimensions WxHxD	102.7 x 107.7 x 120 mm ³ (sensor unit)

3.7.1. Drawings

IMX455 xiray front module
(97mm 2:1 fiber optic taper)

X4G3 Firefly rear module

0,1-2m HQCD-030-STR-TTL-1-2 cable

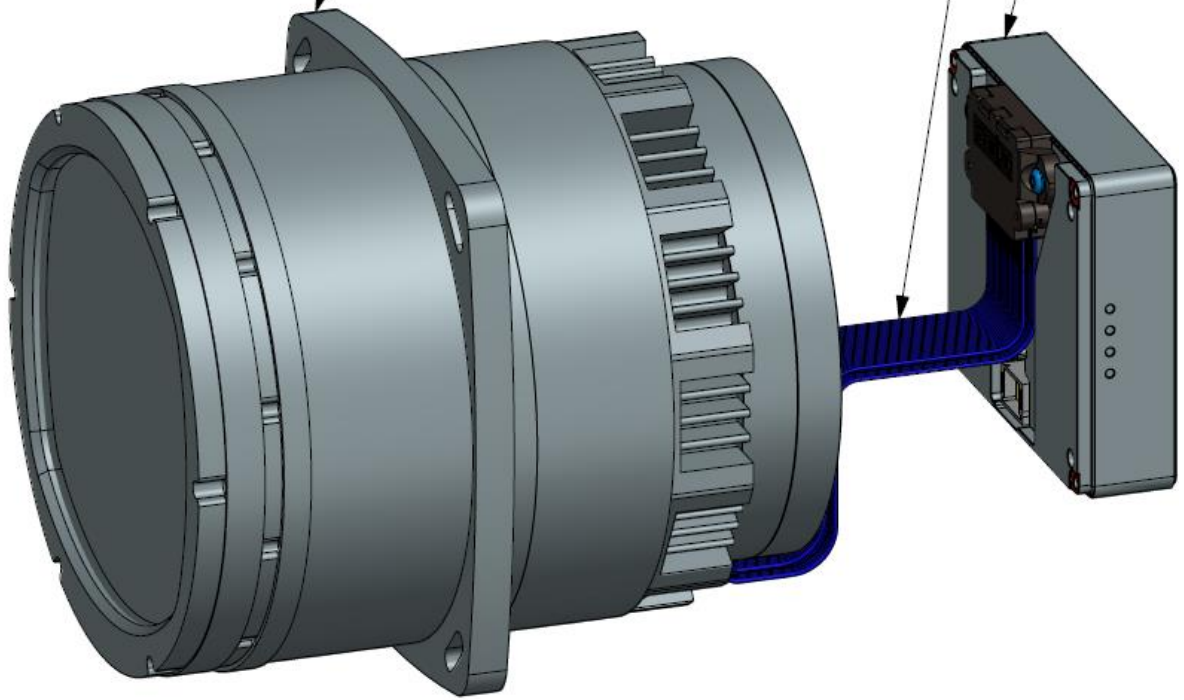

IMX455 xiray front module with taper dimensions

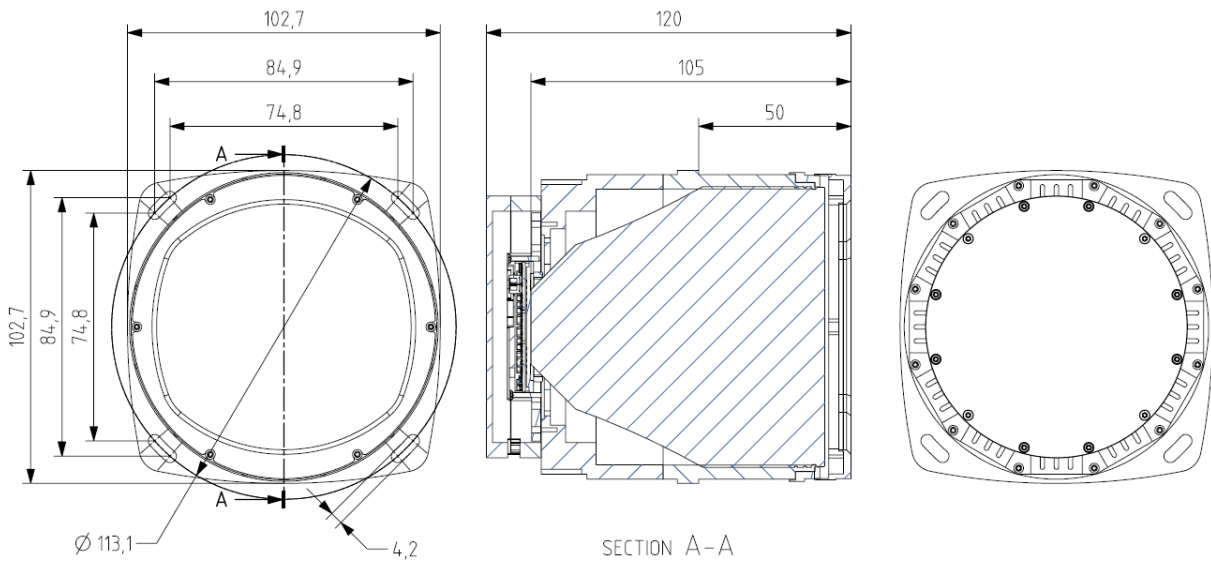

3.7.1. Drawing Firefly rear module

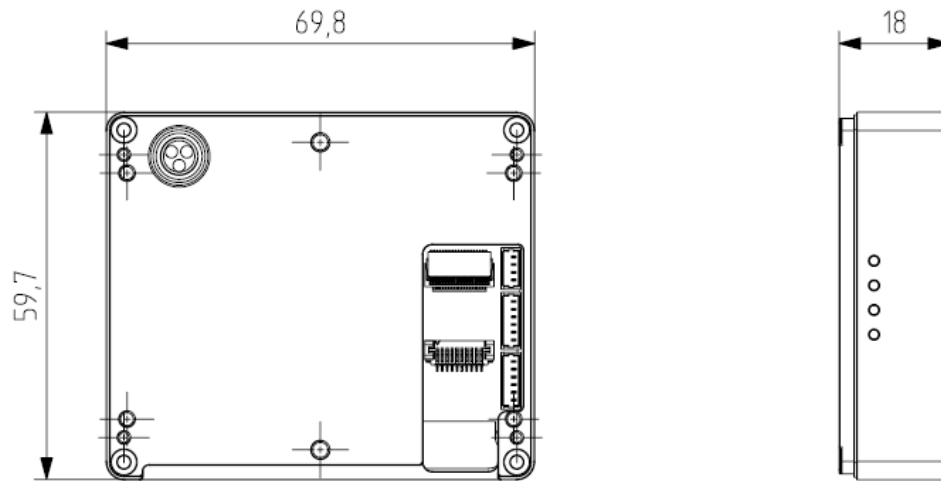

3.7.1.1. Cooling options

Air cooled heatsink option

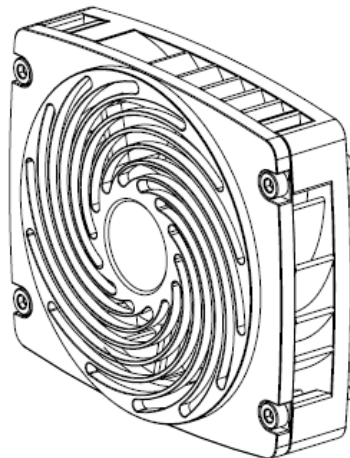

or

Water cooled heatsink option

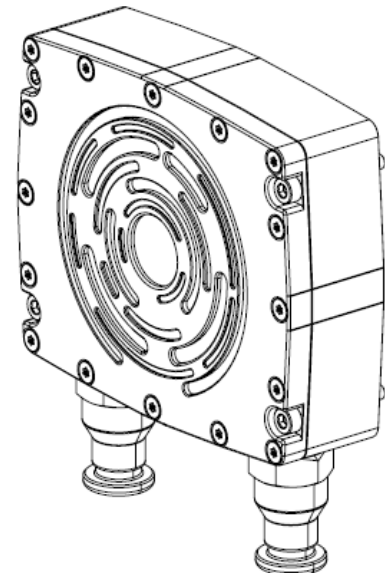

3.7.2. Optional MTP-adapter

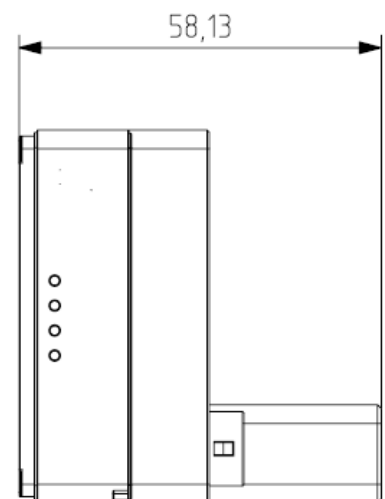
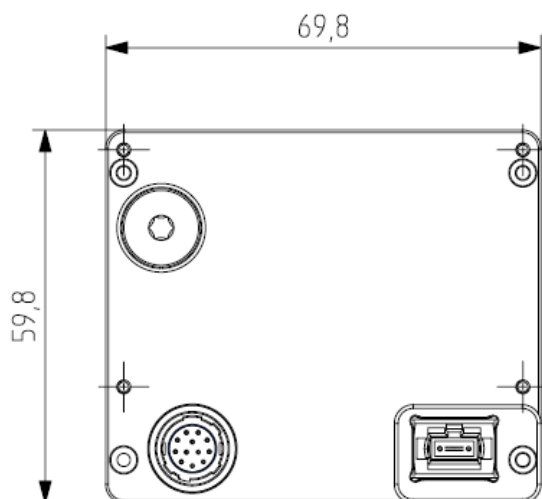
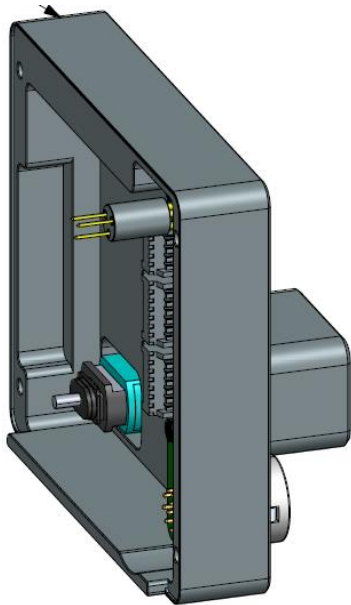

3.7.2.1. Cooling options

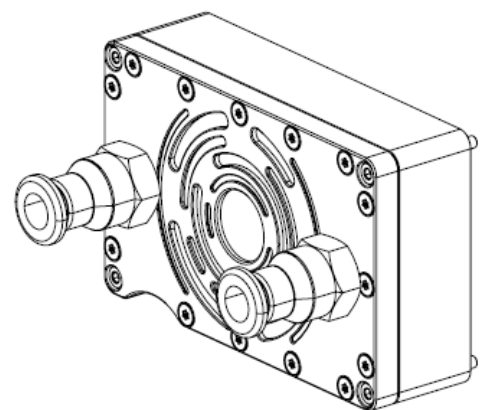
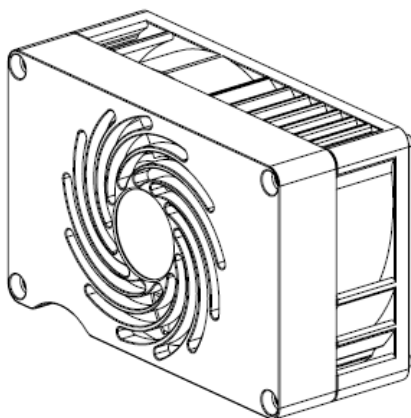

3.8. MX1510XR-SY-FA-GO

Scientific PCIe X-ray CMOS camera, 151MP, 1:1 fiber optic plate, GadOx scintillator
SONY IMX411 CMOS

Sensor unit and electronics are spatially separated from each other and are connected by a ribbon cable. This allows the sensor unit to be cooled passively.

Early engineering samples available

3.8.1. Specifications

Active X-ray image size	60.3 x 47.9 mm ²
Effective pixel size	3.76 μm
Entrance windows	0.5mm Beryllium plate. Radiation hardened glass
Scintillator	GadOx:Eu 10μm thick, 2.5μm grain
X-ray energy level	7 – 100 keV
Resolution	151 MPix, 14192 x 10640 pixels
Frame rates	6 fps @ 12 bit, 2 fps @ 16 bit
Sensor model	SONY IMX411
Sensor type	CMOS, Backside illuminated
Sensor size	Medium format
Sensor active area	60.3 x 47.9 mm ²
Readout method	Rolling shutter
Sensor pixel size	3,76 μm
Digitization	16 Bit
Data interface	PCIe Gen3 x4
Dynamic range	78 dB
Full Well Capacity	50 000 e-
On-Chip binning	1x1, 2x2, 3x3
Readout noise typ.	3 e-
Power consumption	TBD
Dimensions WxHxD	72 x 85 x 20 mm ³ (sensor unit)

3.8.2. Drawings

IMX411 xiray front module
(10mm fiber optic plate)

X4G3 Firefly rear module

0,1-2m HQCD-030-TTL-TTL-1-2 cable

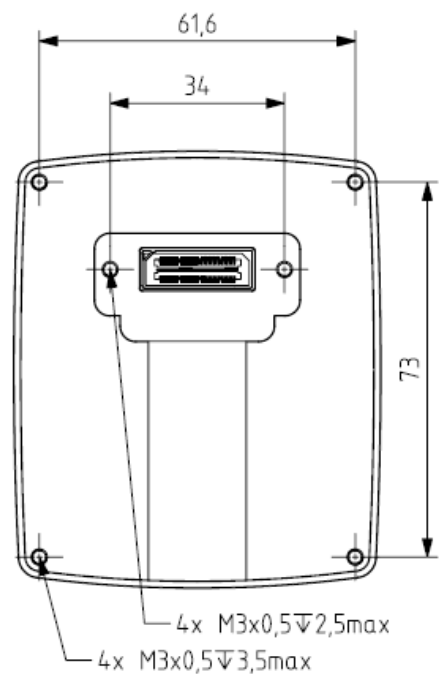
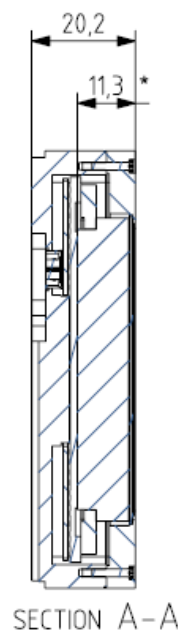
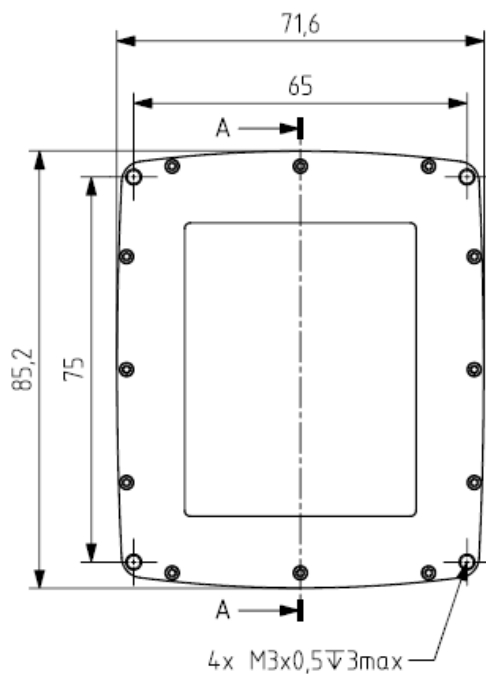
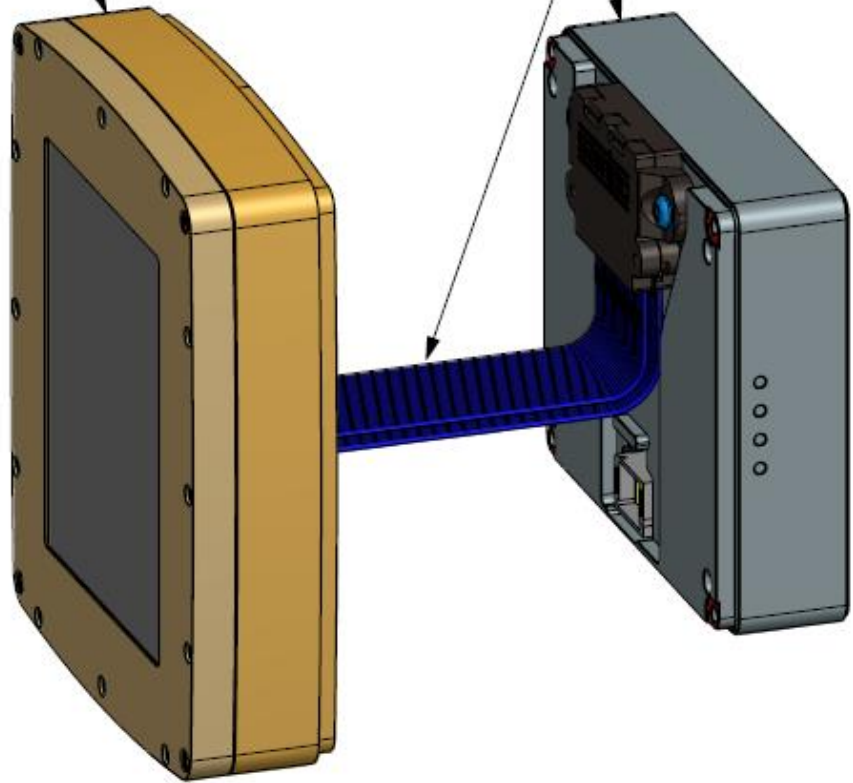

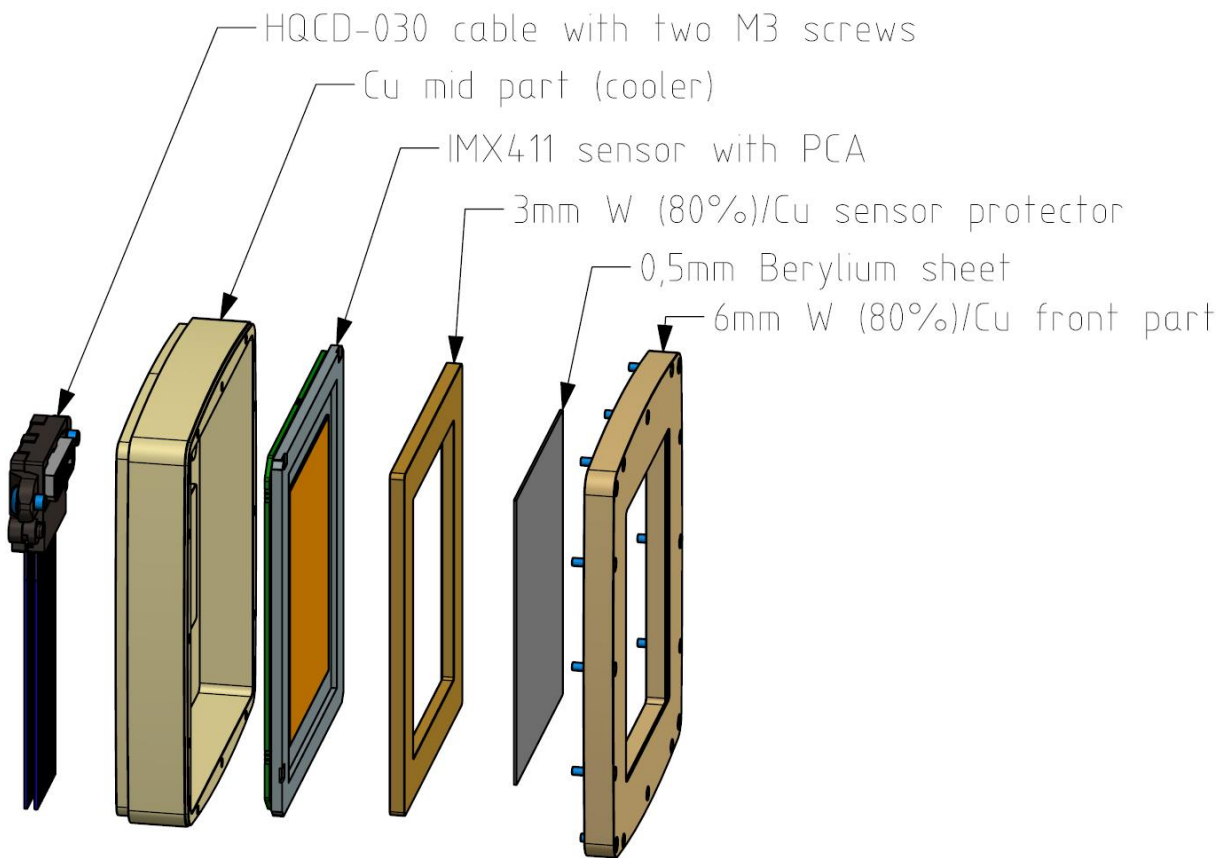
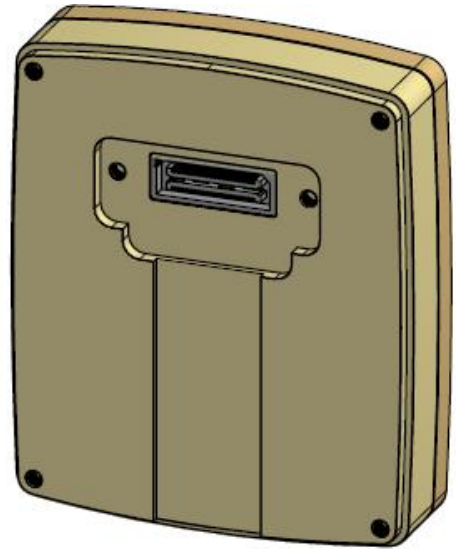
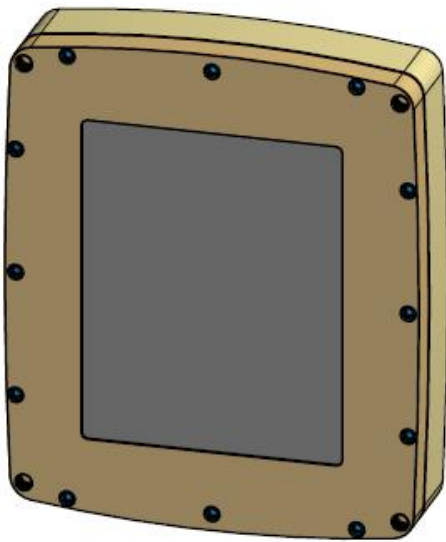

3.8.3. Drawing Firefly rear module

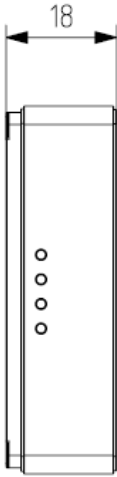
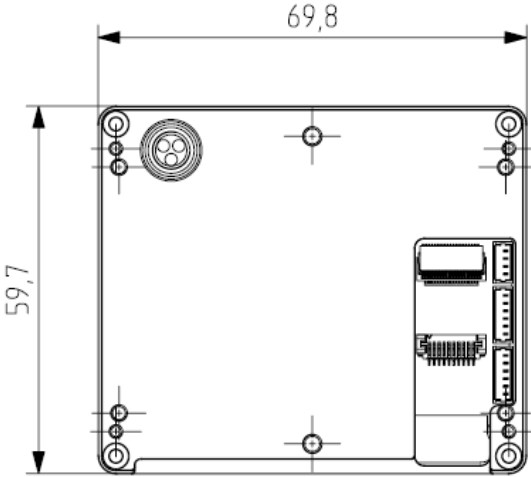

3.8.3.1. Cooling options

Air cooled heatsink option

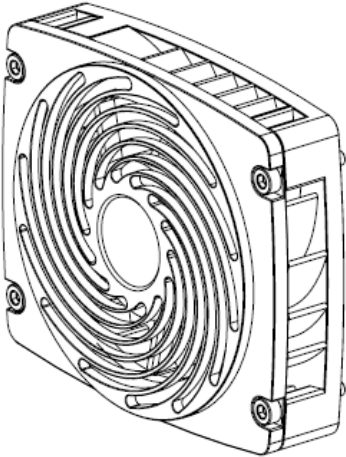

or

Water cooled heatsink option

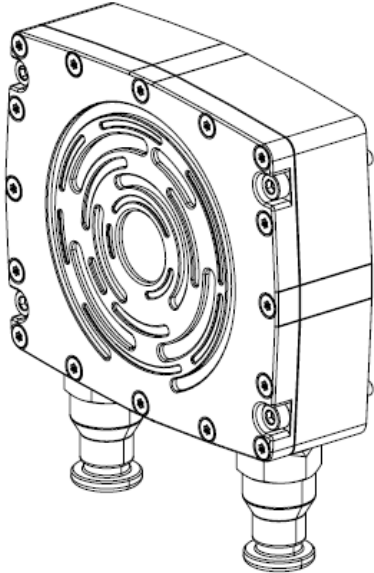

3.8.4. Optional MTP-adapter

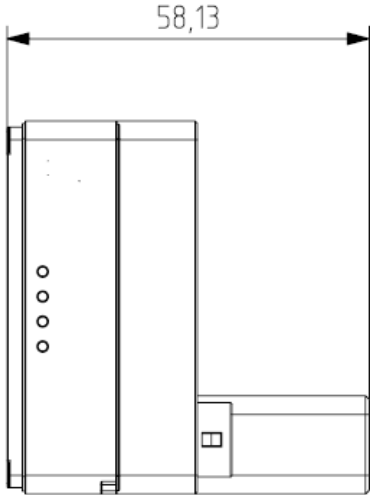
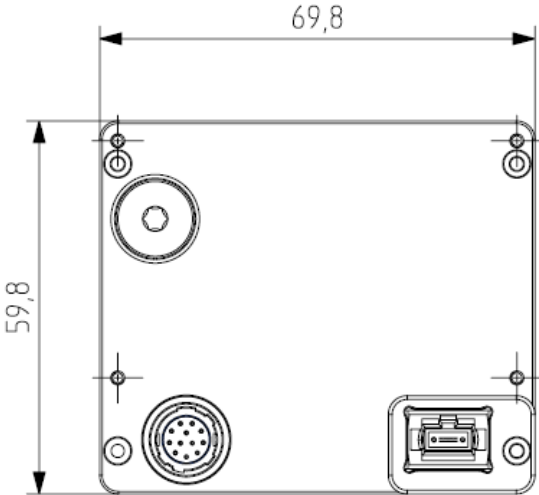
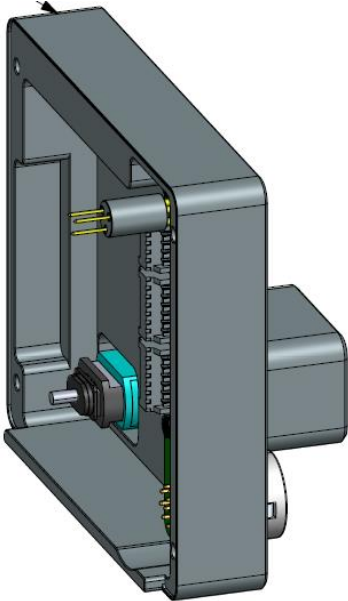

3.8.4.1. Cooling options

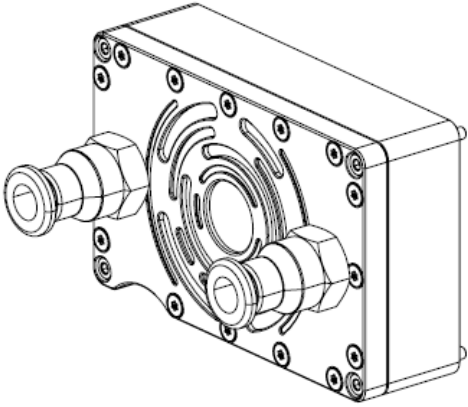
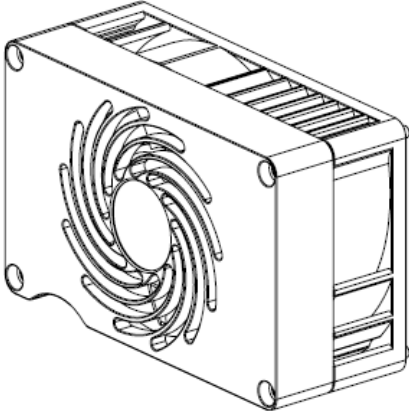

4. Sample images

TBD

5. Features

- Features CCD and sCMOS sensor technology for highest image quality & sensitivity
- Compact camera with full frame sensors with field of view up to 36 x 24 mm
- Fiber optic plate bonded directly to a sensor
- Faceplate scintillators P43 Gd₂O₃:Tb or custom options
- Wavelength: 2.479708-0.1239854 Å
- Low power consumption
- Ultra-precision, aluminum alloy, CNC milled housing

6. Compatibility and contact information

Supported operating systems



macOS

Standards



Language support



Supported vision libraries



and many more ...

上海昊量光电设备有限公司Aunion Tech Co., Ltd

www.auniontech.com

Tel : +86-21-51083793

负责人电话 : 13167190195 李臣阳