

STAR-07 2.0

Options: UV VIS



Single-Color Industrial Pattern Projection



STAR-07 2.0 is a high performance DLP® projector based upon the Texas Instruments micromirror technology and designed to serve in demanding industrial applications. Widely used in multimedia and digital cinema since more than one decade, the well proven DLP technology has become an important tool for industrial solutions as well. The heart of the STAR-07 2.0 projector is a 0.7" DLP chip that consists of an array of 1 024x768 mirrors. These bi-stable mirrors flip into opposite tilt positions within microseconds to generate the desired patterns. STAR-07 2.0 provides precise high-speed control for each individual mirror enabling outstanding flexibility and pattern frame rates of the projection output. The projector is equipped with a high-power LED light source that is the key for the compact and rugged design of the device.

Typical use cases are machine vision illumination, 3D scanning, industrial exposure, and additive manufacturing. Beyond that, new emerging applications are well supported by an open SDK interface. STAR-07 2.0 comes with two lens options, the standard projection lens and a wide angle lens with fixed focal length.

System Architecture

The central control unit of STAR-07 2.0 is USB 2.0 connected and realizes pattern upload, display, and synchronization. An integrated trigger facility supports a wide voltage range at its opto-coupler interface and is software programmable. The digital driver for the LED light source gives convenient access to power setting and temperature reading for thermal management.

System Control

The ViALUX ALP-4.2 Controller Suite is the central programming tool and provides all necessary functionality for product development. Sequences of patterns are uploaded from PC to the on-board memory via USB 2.0 transfer with lossless compression. The properties of the display sequences, e.g. bit depth, picture time, trigger mode, repetitions can be freely defined to meet the respective application requirements. The ALP-4.2 firmware streams patterns from on-board SDRAM memory to the DLP7000 micromirror array where the input pattern is one-to-one mapped to the mirrors. The patterns are updated in the global reset mode; that means all mirrors are switching simultaneously within a few microseconds. Grey value patterns are generated by controlled ON-time for each mirror yielding exact grey value linearity. The maximum global array switching rate is 22 727 fps; even higher frame rates up to 50 kHz can be achieved by partial updates of the micromirror array. Multiple STAR-07

2.0 devices can be run in parallel, conveniently controlled from the same application program and precisely synchronized by the trigger facility. The ALP-4.2 API is well proven and the DLL supports C++, C#, Visual Basic (.NET), Python, MATLAB, LabVIEW, and other development platforms. Microsoft® operating systems are supported up to the most recent Windows® versions both, 32-bit and 64-bit. The ALP-4 USB2.0 driver is robust, validated, UIF compliant and 24/7 proven in industrial and medical use.*

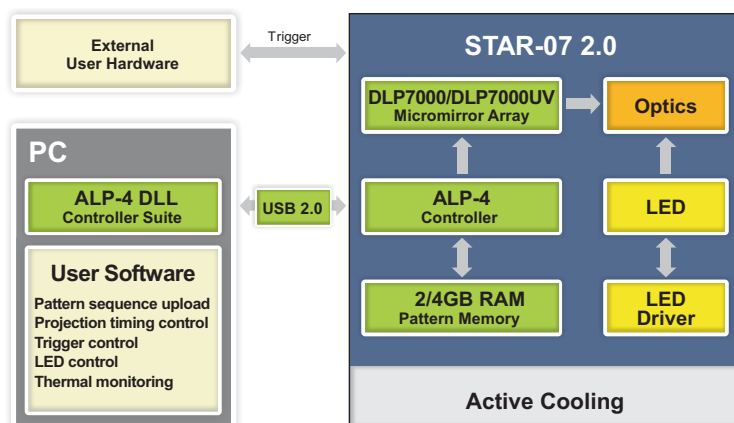

*DLP is a registered trademark of Texas Instruments. Microsoft, Windows, C++, .NET are registered trademarks of Microsoft Cooperation. MATLAB is a registered trademark of MathWorks.





Specifications

LED options

	RED	GREEN	BLUE	VIOLET	WHITE
Typical dominant wavelength	613 nm	525 nm	460 nm	405 nm	-
Spectral bandwidth FWHM	19 nm	34 nm	20 nm	20 nm	-
STAR-07 2.0 output*	330 lm 1450 mW	850 lm 1550 mW	140 lm 2550 mW	- 2150 mW	1100 lm -

* Typical value for continuous projection, pulse operation may yield higher output.

Lens options

	Mass M	Distortion	Working distance D Throw ratio TR	Uniformity (IEC) Contrast FOFO	MTF
Standard lens 	M = 123 g	0.2 %	D > 0.4 m - 10 m TR= 1.8	+25 % / -30 % 2000:1	45 % @36 lp/mm
Wide angle lens 	M = 580 g	5.5 %	D > 0.5 m - 2 m TR= 0.9	+26 % / -23 % @D = 1 m 2000:1	30 % @36 lp/mm @462 nm

Frame rates

DMD array (AOI)	1024 x 768	1024 x 768	1024 x 768	1024 x 768	1024 x 768	1024 x 512
Bit depth	8-bit	7-bit	6-bit	5-bit	1-bit	1-bit
Frame rate	290 fps	569 fps	1091 fps	2016 fps	22727 fps	30300 fps

Greyscale linearity

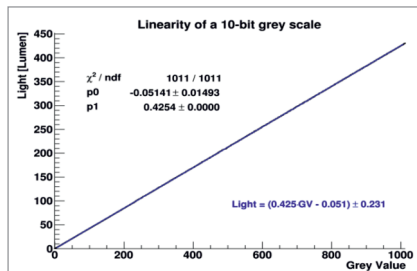

ALP-4 supports precise bit-plane timing enabling outstanding greyscale linearity in connection with synchronized camera recording.

Grey value deviations are < 0.06 % of the full-scale value.

General

Mass (without lens)	Input power	Operating temperature	Storage temperature	Regulations	LED lifetime
2000 g	DC 12-24 V 150 W	10 °C to 40 °C non-condensing	-10 °C to 50 °C non-condensing	CE FCC Class A	> 10000 h (ON time)

Dimensions [mm]

Standard lens	Wide angle lens
