

TeraTune®

The **TeraTune®** provides a tunable narrowband terahertz source with a tuning range from 1.5 to 20 THz and a bandwidth of less than 100 GHz. The basic **TeraTune®** is based on a flash-lamp pumped laser (repetition rate 50 Hz to 200 Hz) with a dedicated optical parametric oscillator (OPO), where one wavelength is tuned electronically with a special design to keep the bandwidth below 100 GHz. Other diode pumped laser systems can be offered. The variable wavelength is calibrated and the THz difference frequency is computer controlled (tuning range 1–20 THz). Terahertz radiation is generated via frequency mixing in the novel organic non-linear optical crystal: DSTMS (4-N,N-dimethylamino-4'-N'-methyl-stilbazolium 2,4,6-trimethylbenzenesulfonate), ideally suited to achieve highest terahertz conversion efficiency.

The **TeraTune®** includes all optical, mechanical, electronic components for the generation of THz waves and software control.

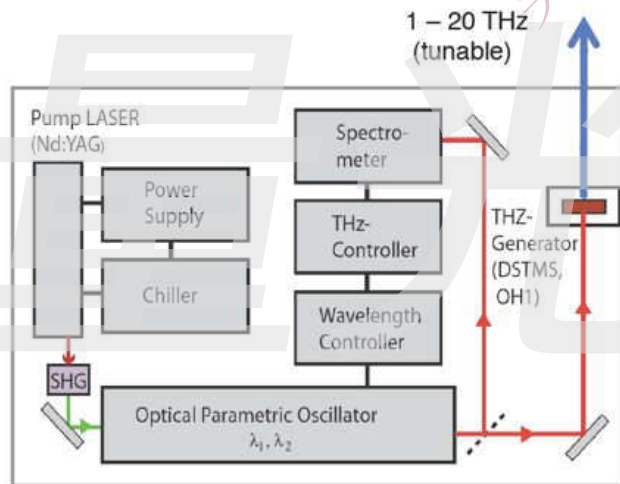

TeraTune® (pump laser, OPO: optical parametric oscillator and THz difference frequency generator, dimensions: 900 x 500 x 180 mm³)



Laser power supply. (300 x 450 x 450 mm³)

Phase matched THz difference frequency generation in DSTMS

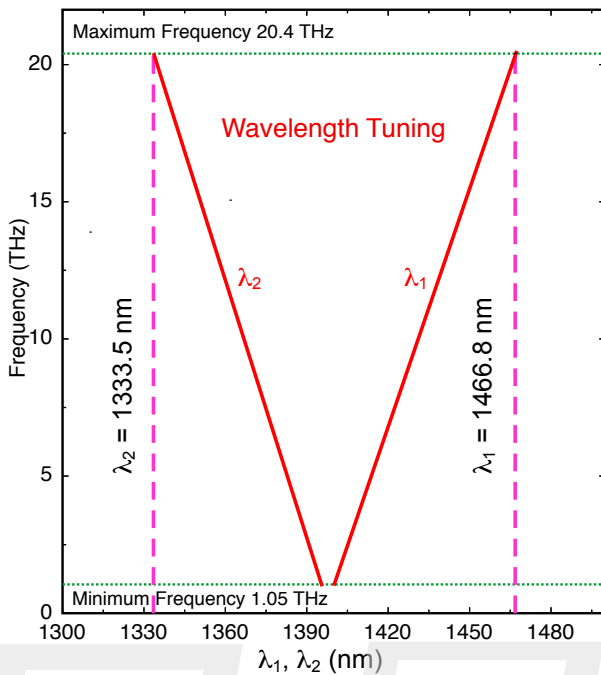

Minimum Frequency Difference

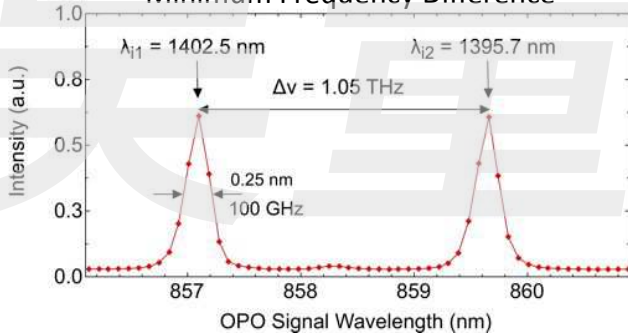

Maximum Frequency Difference

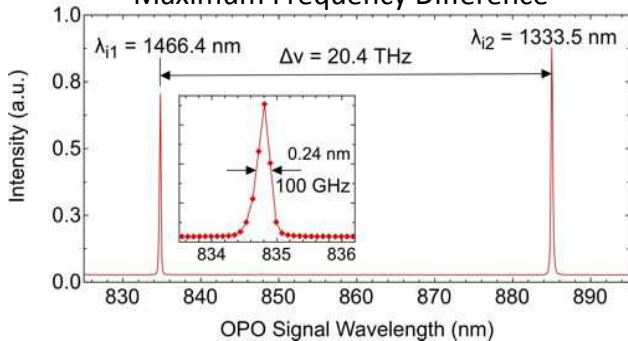

Rainbow Photonics AG

Farbhofstrasse 21
CH-8048 Zürich

Phone: +41 44 419 0505
Fax: +41 44 419 0506
E-mail: info@rainbowphotonics.com
Web: www.rainbowphotonics.com

Tunable frequency

Output frequency	1 – 20 THz
Pulse bandwidth	< 100 GHz
Repetition rate	100 Hz
Average power	1-10 μW
Pulse energy	10-100 nJ
Polarization	linear

OPO: Optical Parametric Oscillator

Tuning range	1330 – 1480 nm
Linewidth	< 100 GHz
Repetition rate	100 Hz
Pulse duration	7 – 10 ns
Energy per pulse	> 10 mJ
Peak Power	> 1.4 MW

Nd:YAG Pump laser 100-Hz

Pulse width	10 ns
Pulse energy	> 125 mJ @ 532nm
Divergence	0.5 mrad
Beam quality	$M^2 < 2$
Energy stability	< 1%
Beam diameter	5 mm
Linewidth	90 MHz
Power consumption	< 2.5 kW

