

FIRST
LIGHT

ADVANCED IMAGERY

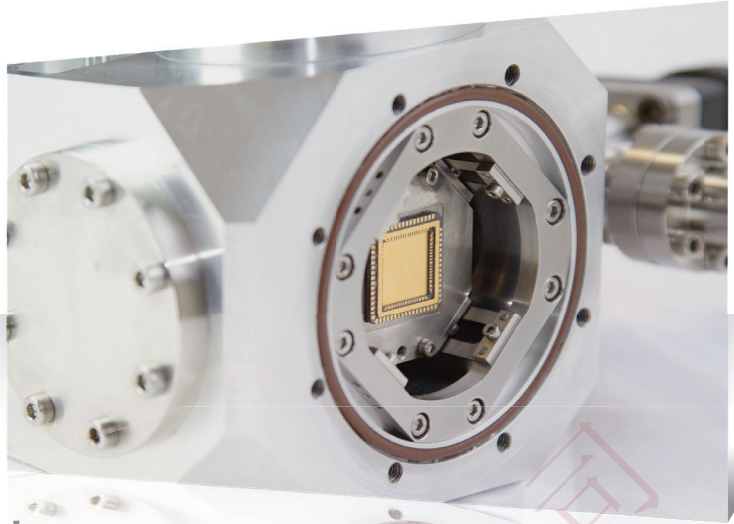

C-RED

Provisional Data Sheet

December 2015

ULTRA LOW NOISE FAST SWIR CAMERA



MAIN FEATURES

- 320X256 revolutionary Avalanche Photodiode Detector (e-APD)
- Wavelength from 1.3 to 2.5 μm (possible extension to 0.8 μm)
- 24 μm pixel pitch
- Subelectron readout noise
- Up to 3500 FPS
- 70% QE
- 16 bits precision A/D converter
- 80 K Operation, integrated pulse tube cooling
- Ultra low latency Cameralink full \otimes interface
- Clock & trigger input/output for synchronous operation.
- Custom design available upon request.
- F/4 or F/2 Aperture.
- Cooled microlens array for wavefront sensing option.



THEORY OF OPERATION

The recent discovery of electron initiated avalanche photodiodes (e-APD) using mercury cadmium telluride (MCT) semiconductor materials permitted a significant breakthrough in short wave (1-2.5 μm) infrared imaging. These diodes have an avalanche gain of up to 100 with an excess noise factor near 1, showing that the avalanche process is quasi deterministic. The hybridization of 320x256 e-APD arrays on silicon read-out circuitry permits to build imagers with fast readout rates (in the kHz range) while having at the same time a subelectron readout noise , which is a major improvement compared to previous infrared imaging technologies. The technology used to manufacture e-APDs is similar to the one used for standard HgCdTe diodes with a 100% fill factor, therefore a high quantum efficiency (typically QE=70-75 %) is maintained.

Today First Light Imaging makes this technology available to everybody : C-RED is opening a new era in terms of sensitivity and speed in the SWIR scientific cameras domain.

C-RED is using a unique 320x256 pixels HgCdTe e-APD array with 24 μm pixel pitch. The sensor cutoff wavelength is 2.5 μm and it allows sub-electron readout noise, taking advantage of the e-APD noise-free multiplication gain and non-destructive readout ability. **C-RED** is also capable of multiple regions of interest (ROI) readout allowing faster image rate (10's of KHz) while maintaining unprecedented subelectron readout noise.

The sensor is placed in a sealed vacuum environment and cooled down to cryogenic temperature (80K) using an integrated pulse tube, with a high reliability (MTBF > 90 000 h) much higher than standard stirling coolers used usually with cooled infrared arrays.

C-RED PROVISIONAL PERFORMANCES

Test measurement	Result	Unit
Maximum speed	3507	FPS
Mean Dark + Readout Noise at 3500 fps and gain ~ 30	<1	e-
Quantization	16	bit
Detector Operating Temperature	80	K
Peak Quantum Efficiency from 1.3 μm to 2.5 μm	>70	%
Operability \pm 30%	99.3	%
Image Full well capacity at gain X1, 3500 fps	200 000	e-
Excess noise Factor F	1.25	n/a

PRELIMINARY RESULTS

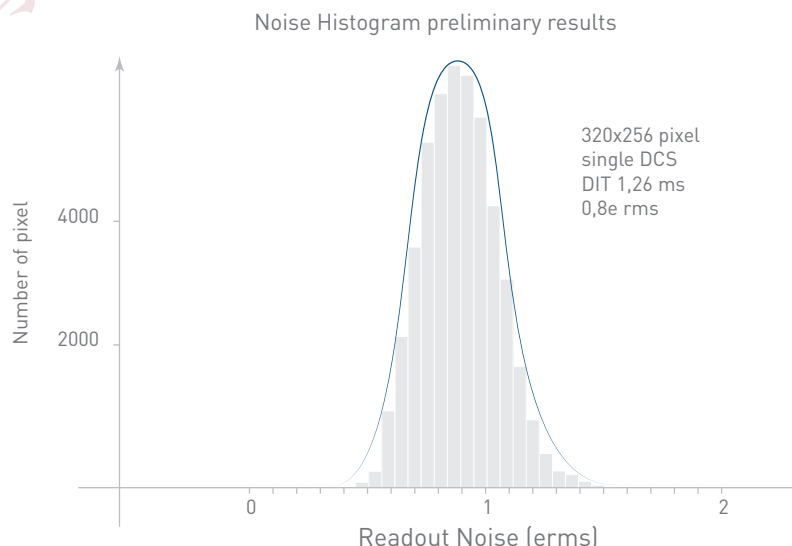

C-RED

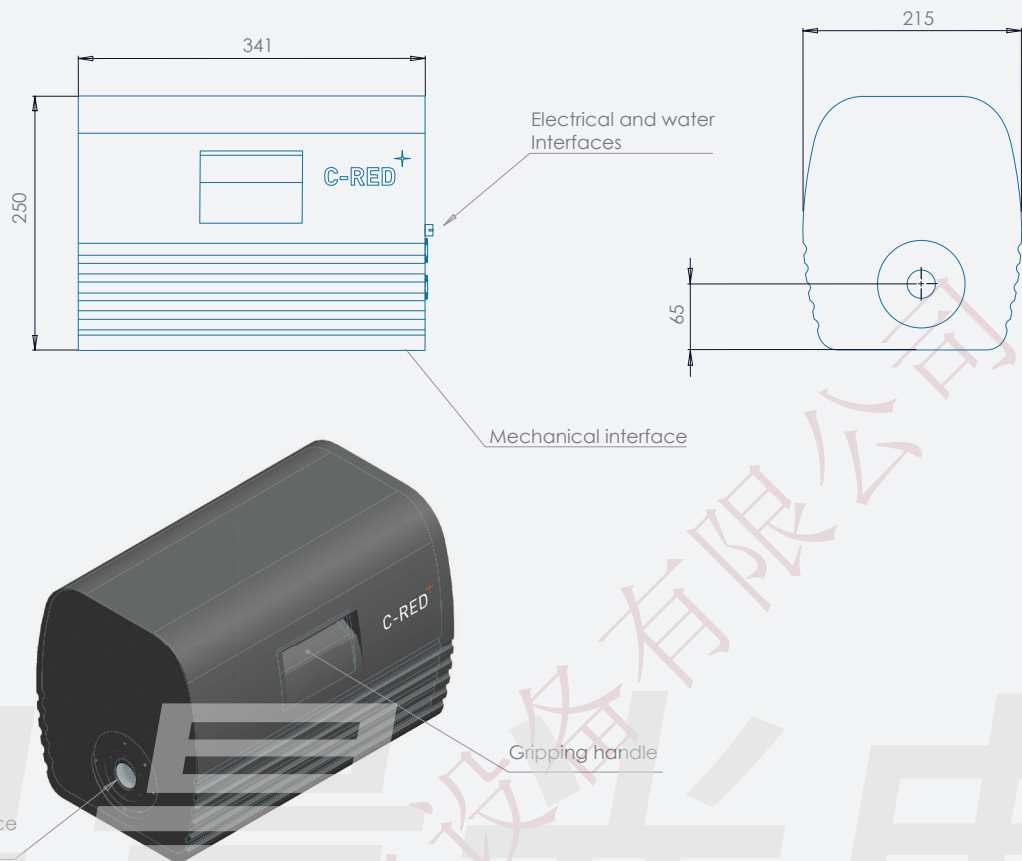

APPLICATIONS

C-RED can be used in various fields:

- Adaptive Optics for Astronomy
- Cellular Microscopy
- Space Debris Tracking
- Fluorescence Microscopy
- Fringe Tracking
- Raman Spectroscopy
- Hyperspectral Imaging
- Speckle Interferometry
- Astronomical Observations with Interferometers
- Secure Laser Communications (long distance, space to ground)
- Long range surveillance and Tracking
- OCT imaging

AVAILABILITY 2015, contact us for more information.

OUR CUSTOMERS AND PARTNERS

Today, world leading institutes and manufacturers on 4 continents have given us their trust, and we are proud to count among our partners and clients:

AIRBUS
GROUP

GIANT MAGELLAN TELESCOPE

e2V



NASA-JPL



中国科学院
CHINESE ACADEMY OF SCIENCES



Chengdu Institute of Biology
Chinese Academy of Sciences

Hitachi High-Tech



Observatoire
de la COTE d'AZUR

OUR COMPANY

First Light Imaging designs and manufactures state of the art scientific cameras that combine extreme sensitivity and high speed for both visible and infrared spectra.

Coming from European academic research institutes, already multiple award-winning, First Light Imaging is recognized for the high performance of its products.

We develop our cameras around cutting-edge sensors. EMCCD or e-APD, we integrate the most challenging, difficult to harness detectors in complex optics systems.

Already at the heart of the Adaptive Optics systems for the world's biggest telescopes, our technology and detectors are also used in Medical Imagery, Defense, and Industry.

First Light Imaging SAS
100 route des Houillères
13590 Meyreuil
France
Tel.: + 33 4 42 61 29 20
www.first-light.fr
contact@first-light.fr



The project leading to this application has received funding from the European Union's Horizon 2020 research and innovation program under grant agreement No 673944