

Electro-Optic Components and Systems

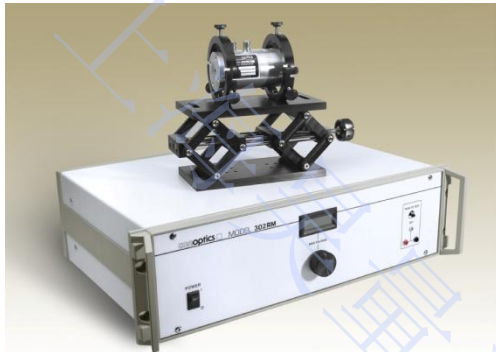

Choose from our line of modulators and driver electronics

Conoptics manufactures an extensive line of low voltage electro-optic light modulators, driver electronics and associated components to satisfy your diverse requirements. Your application will dictate which version of modulator and driver electronics you need and what auxiliary components you should use. The technical tables listed here provide detailed information to assist in your decision making process.

Drive Electronics

In general, the first application requirements considered in the choice of modulation system components are the information bandwidth and waveform requirement. The driver output voltage achievable is a function of amplifier bandwidth and, while this system parameter is not isolated from others, such as aperture diameter, operating wavelength, etc., it is normally the limiting parameter of the system.

Optical Modulators

All modulators listed in this data sheet are of the transverse field type, that is, the electric field produced by the applied signal voltage is perpendicular to the optical propagation direction. The voltage swing required by a given modulator at a given operating wavelength to transit between the full off state to the full on state is called the Half Wave Voltage ($V_{\frac{1}{2}}$). The transverse field structure allows reduction of $V_{\frac{1}{2}}$ by manipulation of the crystal length to aperture ratio to a level achievable by available driver electronics. $V_{\frac{1}{2}}$ is roughly proportional to wavelength and long wavelength devices usually require higher length to aperture ratios to accommodate existing driver output levels. Conoptics offers modulators constructed with three different crystal species: Ammonium Dihydrogen Phosphate (ADP), Potassium Dideuterium Phosphate (KD*P), and Lithium Tantalate (LTA). Models 370, 380, and 390 utilize ADP as the active element. The unique feature of these models is the virtual non-existence of piezoelectric resonances. Models belonging to the 360 series utilize LTA. LTA has the lowest intrinsic $V_{\frac{1}{2}}$ and the longest wavelength IR cutoff. Furthermore, it has a combination of high refractive index and relatively low dielectric constant which allows modulators to be designed which make full use of the intrinsic driver frequency response. Models in the 360 series exhibit piezoelectric resonances but they are discrete and very narrow. KD*P is used in Model 350 series modulators. In terms of optical transmission bandwidth and driver frequency response utilization, this series falls in between ADP and LTA versions. Table 1 below provides the specifications our ADP (240-to-800nm), KD*P (240-to-1100nm) and LTA (700-2000nm) series modulator product line.

Table 1 Modulator Specifications:

	Model Number	$V_{\frac{1}{2}}$ wave @ 500nm	$V_{\frac{1}{2}}$ wave @ 830nm	$V_{\frac{1}{2}}$ wave @ 1064nm	$V_{\frac{1}{2}}$ wave @ 2500nm	Aperture Diameter	Resonances	Contrast Ratio @ 633nm and 1064nm	Length w/ Polarizer
<i>ADP Crystal Series Wavelength Limits (240 to 800nm)*</i>	MAD	184	--	--	--	2.5mm	No	500:1, N/A	158mm
	MAD	263	--	--	--	3.5mm	No	500:1, N/A	158mm
	MAD	92	--	--	--	2.5mm	No	500:1, N/A	253mm
	MAD	115	--	--	--	3.5mm	No	500:1, N/A	272mm
<i>KD*P Crystal Series Wavelength Limits (240 to 1100nm)*</i>	MKD -50	455	757	970	--	3.1mm	Yes **	500:1, 700:1	106mm
	MKD -80	261	433	522	--	2.7mm	Yes	500:1, 700:1	137mm
	MKD -	360	600	720	--	3.5mm	Yes		137mm
	MKD -	226	376	472	--	3.1mm	Yes	500:1, 700:1	162mm
	MKD -	130	216	275	--	2.7mm	Yes	300:1, 500:1	215mm
	M350-	113	188	240	--	3.1mm	Yes	300:1, 500:1	268mm
<i>LTA Crystal Series Wavelength Limits (700 to 2000nm)</i>	MLT -	--	312	400	950	2.7mm	Yes	N/A, 200:1	95mm
	MLT -	--	143	183	430	2.7mm	Yes	N/A, 100:1	137mm
	MLT -	--	107	138	323	2.7mm	Yes	N/A, 100:1	174mm
	MLT -	--	71	92	215	2.7mm	Yes	N/A, 100:1	215mm

Special Notes

- Special Order wavelengths below 400nm are available
- Special Clamped version available to minimize Piezo-electric resonances
- To determine the $\frac{1}{2}$ wave voltage at your operating wavelength, compute the voltage listed and multiply it by the ratio of the wavelengths. (i.e. M350-50 @ 700nm = $455 \times 700 / 500 = 637$ Volts)
- The last digits of the Model Number for the 350 and 360 Series designate the total crystal path length in millimeters.

Modulator Modifications

Any of the modulators listed here can be used as a phase modulator by simply rotating the input polarization direction by 45° . This procedure makes one of the modulator half segments essentially inactive and doubles $V_{\frac{1}{2}}$ (now the voltage required for a 180° phase shift). A factory modification can be made during construction which restores $V_{\frac{1}{2}}$ to its original value. This modification precludes use of the device as an intensity modulator, however, and is irreversible.

昊量光电

Amplifier Specifications

Table 2 listed below provides the basic specifications of our line of amplifiers and the interface configuration to the modulators. All of our amplifiers include a DC Bias Supply with greater than +/- 250 volts for setting the modulators operating point. The lump capacitance amplifiers have (2) BNC cables driving the modulator push-pull. The 50 ohms S.E. configuration has (2) SMA connectors for driving a 50 ohm single ended modulator and a third connector (BNC) for DC Bias. The 100 ohm and 50 ohm balanced line configuration has (2) twinax connectors for driving a balanced line modulator and a third miniature twinax connector for the DC Bias.

Table 2 Amplifier Details

Bandwidth	Rise/Fall Times	Max. Output V	Typical Drive Configuration	Output
DC TO 25MHz	14ns	145	100 Ohms B.L.	Analog
DC TO 30MHz	8ns	175	100 Ohm's B.L.	Digital
DC TO 50MHz	7ns	90	50 Ohms B.L.	Analog
DC TO 100MHz	3.5ns	90	50 Ohms B.L.	Analog
10KHz TO 200MHz	-	170	50 Ohms S.E.	-
DC TO 8MHz	50ns	275	Lumped Capacitance	Analog
DC TO 250KHz	1micro sec	750	Lumped Capacitance	Analog
DC TO 1MHz	350ns	350	Lumped Capacitance	Analog
DC TO 50KHz	8ns	800	Lumped Capacitance	Digital
20 TO 100MHz	-	44	50 Ohms S.E.	-
50 TO 500MHz	-	140	50 Ohms S.E.	-

Modulation Systems

The modulators and drivers listed in this data sheet can be used in various combinations to form high performance, cost effective modulation systems. Table 3 shows the key performance characteristics of various combinations of standard driver electronics and modulators. The high frequency -3dB points may be limited either by the driver or the modulator. Rise and fall times are normally calculated as 0.35 divided by the -3dB bandwidth but, due to the compression caused by the sine squared transfer characteristic over its full on to off range, the optical rise and fall times of these systems is approximately 20% less.

昊量光电



Dispersion Data:

Model 360-80						
Calculates index dispersion and/or pulse elongation for several materials.						
LTA average						
A = 4.52118266929						
B = .0848939034985						
C = .0397341352617						
D = 27.2917136782						
E = 1156.32081918						
Form is $n^2 = A + B/(L^2 - C) + D * L^2 / (L^2 - E)$						
<u>Lambda</u>	<u>n</u>	<u>dn/dL</u>	<u>d2n/dL2</u>	<u>d3n/dL3</u>	<u>d4n/dL4</u>	
.7000	2.16752	-.14286	+.62742	-4.11610	+34.23492	
.7500	2.16109	-.11601	+.45775	-2.77728	+21.14312	
.8000	2.15581	-.09620	+.34153	-1.93363	+13.58106	
.8500	2.15139	-.08129	+.25956	-1.38243	+9.01732	
.9000	2.14762	-.06987	+.20031	-1.01109	+6.15902	
.9500	2.14436	-.06100	+.15656	-.75424	+4.31100	
1.0000	2.14149	-.05403	+.12365	-.57246	+3.08275	
1.0500	2.13893	-.04851	+.09848	-.44119	+2.24645	
1.1000	2.13662	-.04409	+.07895	-.34470	+1.66473	
PULSE ELONGATION IN FEMTOSECONDS vs WAVELENGTH FOR A 80mm LENGTH						
<u>Delta Lambda/Lambda</u>						
<u>Lambda</u>	<u>0.1%</u>	<u>0.2%</u>	<u>0.4%</u>	<u>0.8%</u>	<u>1.6%</u>	<u>3.2%</u>
.7000	82	164	328	657	1321	2695
.7500	69	137	275	550	1106	2256
.8000	58	117	233	467	939	1914
.8500	50	100	200	401	805	1641
.9000	43	87	173	347	697	1420
.9500	38	75	151	302	607	1236
1.0000	33	66	132	264	531	1082
1.0500	29	58	116	232	466	950
1.1000	25	51	102	204	410	836

- Bandwidth Calculation notes
%Bandwidth = wavelength in microns / pulse width in fsec

Model 350-160

Calculates index dispersion and/or pulse elongation for several materials.

KD*Pe

A = 2.12538053178

B = .00886632607593

C = .00815373335291

D = 2.28110628422E+12

E = 3.78851499211E+14

Form is $n^2 = A + B / (L^2 - C) + D * L^2 / (L^2 - E)$

<u>Lambda</u>	<u>n</u>	<u>dn/dL</u>	<u>d2n/dL2</u>	<u>d3n/dL3</u>	<u>d4n/dL4</u>
.7000	1.46316	-.02115	+.07564	-.46711	+3.43939
.7500	1.46219	-.01789	+.05602	-.32773	+2.24331
.8000	1.46136	-.01545	+.04209	-.23552	+1.50647
.8500	1.46063	-.01362	+.03198	-.17284	+1.03763
.9000	1.45999	-.01221	+.02449	-.12919	+0.73079
.9500	1.45940	-.01114	+.01885	-.09815	+0.52493
1.0000	1.45887	-.01031	+.01454	-.07566	+0.38375
1.0500	1.45837	-.00967	+.01119	-.05910	+0.28500
1.1000	1.45790	-.00917	+.00856	-.04671	+0.21470

PULSE ELONGATION IN FEMTOSECONDS vs WAVELENGTH FOR A 160mm LENGTH

<u>Lambda</u>	<u>Delta Lambda/Lambda</u>					
	<u>0.1%</u>	<u>0.2%</u>	<u>0.4%</u>	<u>0.8%</u>	<u>1.6%</u>	<u>3.2%</u>
.7000	20	40	79	158	318	647
.7500	17	34	67	135	270	550
.8000	14	29	57	115	231	471
.8500	12	25	49	99	198	404
.9000	11	21	42	85	170	347
.9500	9	18	36	73	146	298
1.0000	8	16	31	62	125	255
1.0500	7	13	26	53	106	217
1.1000	6	11	22	44	89	182

M25D driving 350-160 detected @ 514nm

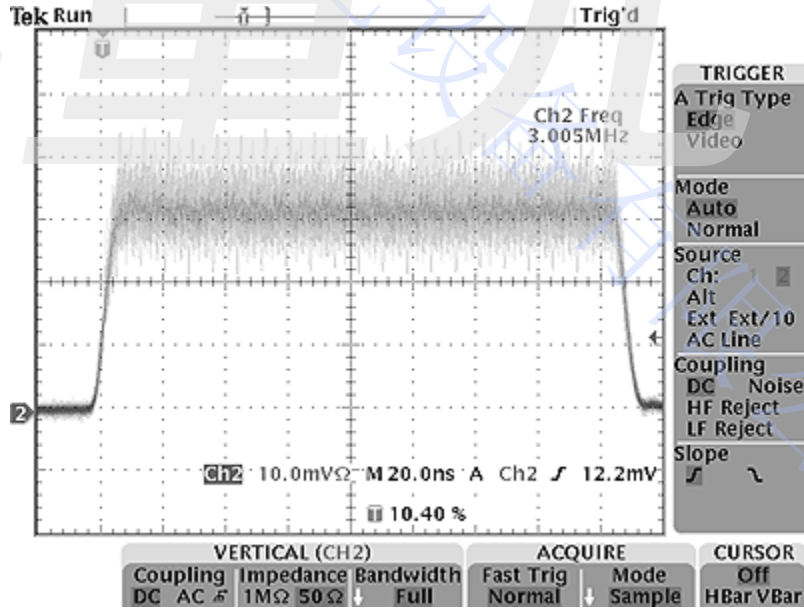
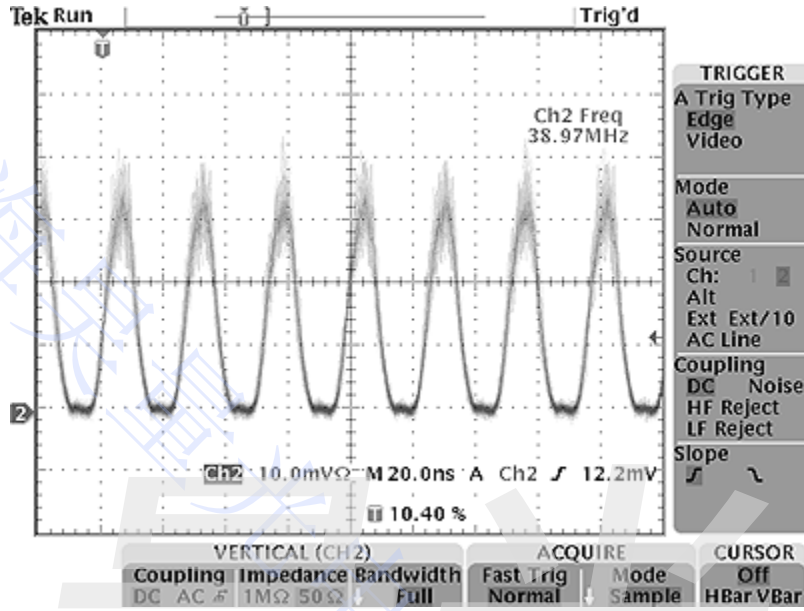

PHASE MODULATORS

The standard modulators 350, 360, 370, 380 and 390 series are built as intensity modulators with a polarizer aligned to the crystal axis. The same modulators can also be configured for use as polarization rotators, voltage variable wave plates or phase modulators. However, when used as phase modulator only half the cell is active, so the half wave voltage is twice as high as compared to the standard use.

All of our modulators can be constructed with all the crystals inline such that the full cell is active as a phase modulator, but in this configuration it cannot be used as an intensity modulator, polarization rotator or variable wave plate. Once the modulator is built as a phase modulator it cannot be re-configured as an intensity modulator.

KD*P Series	Phase Sensitivity mrad/volt @ 500nm	V for ½ Wave Phase Modulator
350-50LA	3.85	815
350-50	7	450
350-80	12	261
350-105	14.7	225
350-160	24	130
350-210	29	113
ADP Series	Phase Sensitivity mrad/volt @ 500nm	V for ½ Wave Phase Modulator
370LA	12	262
370	17	184
380	34	90
390	27	115
LTA Series	Phase Sensitivity mrad/volt @ 830nm	V for ½ Wave Phase Modulator
360-40	13	242
360-80	26	120
360-120	39	80
360-160	52	60

PHASE MODULATOR ALIGNMENT

Linearly polarized light must be passed through the modulator so that that the plane of polarization is orthogonal* to the applied field (see figure 1)

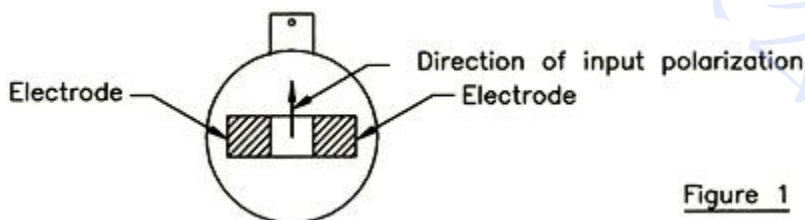
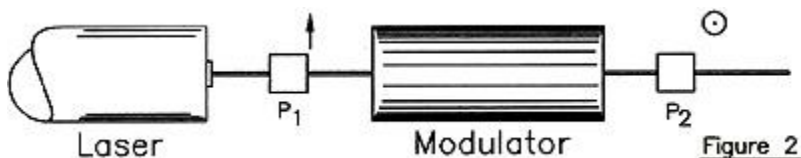

Figure 1

* For 350/370/380/390 Series
For 360 Series "plane of polarization is parallel"

To perform the alignment of the phase modulator, the optical setup must contain a polarized laser (or an input polarizer (P_1) if the laser is unpolarized) and an output polarizer (P_2) positioned so that

its pass direction is orthogonal to the input (see figure 2)



Align the phase modulator (with the connector vertical or parallel to the input polarization) so that the laser beam is centered on the input and the exit crystal faces. Rotate the modulator until a null is observed, after P₂. This will align the input polarization parallel to the induced index change. Then remove P₂

A suitable modulator support must be provided so that adjustments of the modulator can be made in roll, pitch and yaw. (see figure 3)

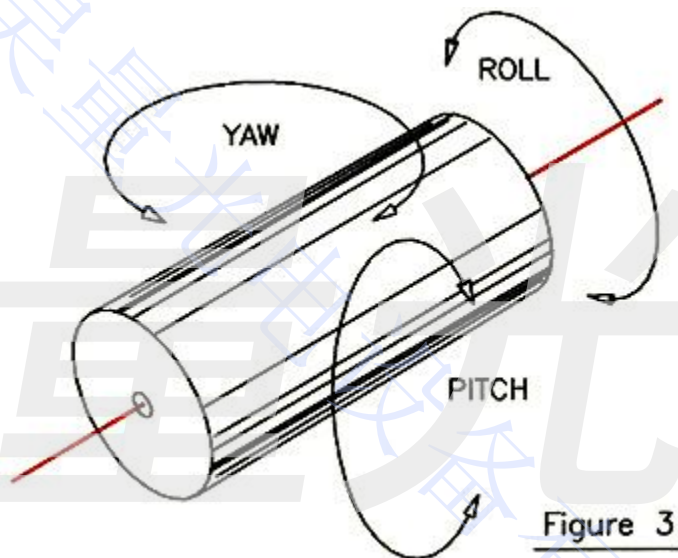

RESONANT CIRCUIT E.O. INSTALLATION DIAGRAM

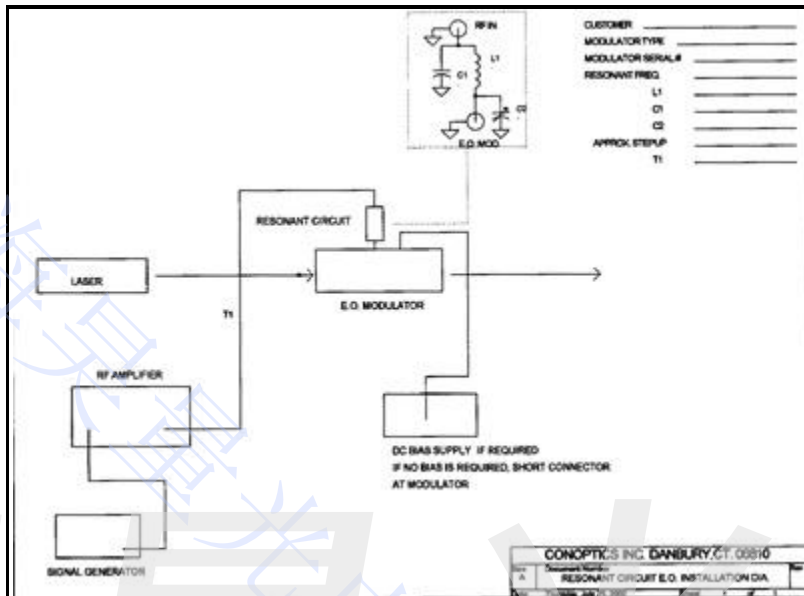

[\(Click for larger view. » \)](#)

MODULATOR MOUNTING ASSEMBLY

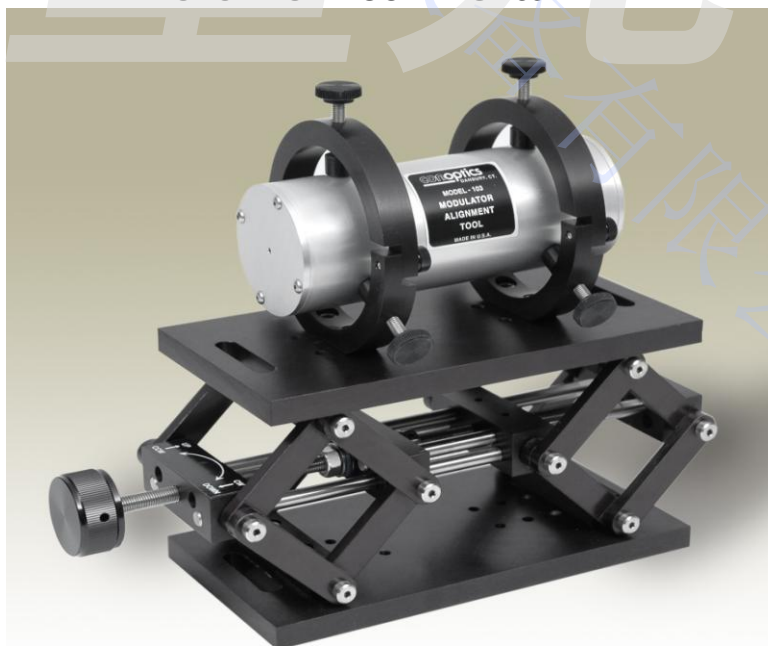

Key features:

Height Adjustment Range:	2.6 inches (6.6cm)	
	Lowest Center Line	4.15", 10.5cm
	Highest Center Line	6.75", 17.2cm
Height without Mounting Rings:	Fully Retracted Height	2.30", 5.8cm
	Fully Extended Height	4.90", 12.4cm
	Weight	3.33lbs.
Height with Mounting Rings: (Center of Ring)	Fully Retracted Height	3.90", 9.9cm
	Fully Extended Height	6.50", 16.5cm
	Weight	3.95lbs.
Dimensions: (Overall L x W x H)	Fully Retracted w/o Rings	10"L x 3.6"W x 2.3"H
		25.4cm x9.1cm x 5.8cm
	Fully Extended w/o Rings	10"L x 3.6"W x4.9"H
		25.4cm x9.1cm x12.4cm
	Fully Retracted with Rings	10"L x 3.6"W x 6.3"H
		25.4cm x9.1cm x 16cm
	Fully Extended with Rings	10"L x 3.6"W x 8.9"H
		25.4cm x9.1cm x 22.6cm
Alignment Tool Option:	Diameter is 5cm	Aperture 2mm