

Optical Isolators



700 Series Faraday Rotator and Accessories

The unique feature of a Faraday rotator is its non-reciprocity, that is, the fact that the "handedness" of the polarization rotation it imparts on a transmitted beam is dependent on the beam's propagation direction. By far the most common application of Faraday rotators is their use in optical isolators, devices used to protect laser sources from harmful back reflections.

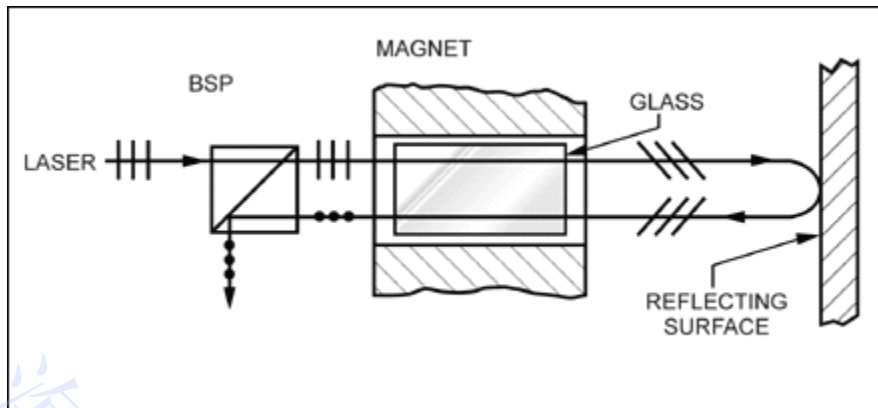

FIGURE 1: A basic optical isolator

Conoptics manufactures a family of modular Faraday rotators and interchangeable accessories which can be combined to perform various isolation functions. A basic optical isolator is shown in Figure 1. Light from a presumed well polarized laser source enters an aligned beamsplitting polarizer from the left. It then proceeds through a Faraday rotator which is tuned to 45° for the particular laser wavelength. Only one magnet is shown but, whether a single magnet or a three magnet array is used, its major field component is parallel to the optical propagation direction. Light returning from any downstream reflecting surface undergoes an additional 45° rotation in its backward pass through the glass. It is now polarized orthogonal to the forward beam and is rejected by the polarizer.

Faraday Rotators

The Faraday rotators included in the 700 Series consist of one or more high flux NIB permanent magnets and a terbium glass element. Tuning is accomplished by moving the glass between regions of high and low field strength. An important feature of the Conoptics design is that the glass does not rotate as it is moved thereby eliminating the possibility of transmitted beam nutation due to residual wedge. Polarization rotation is a function not only of the axial magnetic field strength, but also of the glass length, L , and its Verdet constant, V . More precisely, on axis where z is along the propagation direct.

$$1) \Theta_F = V \int_{z_0}^{z_0+L} H_z dz$$

ConOptics, Inc. 19 Eagle Road, Danbury, CT 06810 Phone 800-748-3349 Fax 203-790-6145
 Contact: sales@conoptics.com, Website: www.conoptics.com

The value of V is strongly wavelength dependent and diminishes rapidly as wavelength increases. In order to avoid the need for extending the length of glass elements to achieve 45° rotation at long wavelengths, the local field strength must be increased by using combinations of magnets with opposing fields. The Model 713, 714, and 715, while outwardly quite large, have only a fraction of their lengths filled with glass. The magnet array design is intended to increase axial field strength but also affects the field radial uniformity. Only relatively small volumes along the axis of the magnet array offer sufficiently low gradients. Furthermore, tuning the rotator (changing Z_0 in equation 1) by definition means moving the glass into a region of lower integrated axial field strength and higher gradients. It is generally recommended, therefore, that for best isolation ratio, a model be chosen in which the intended operating wavelength is near the upper end of the tuning range. A strong absorption peak at approximately 490nm is typical of terbium glass. At wavelengths larger than 500 nm absorption is low and the models listed are capable of operation with more than 6 watts average power. Operation at 488 nm is not recommended but a special unit operable at 458 nm is available. TABLE 1 lists the specifications of standard Conoptics Faraday rotators. The isolation ratio (extinction) is dependent on the type of polarizer(s) used, the operating wavelength in relation to the tuning range, and beam diameter.

Polarizer's

Figure 1 shows that it is actually the polarizer that performs the beam separation function in an optical isolator. It is an obvious fact that, while the homogeneity of the Faraday rotator is of critical importance and generally limits performance in single stage devices, the extinction of the isolator can be no better than the extinction of the polarizer. Conoptics offers the Model 720 polarizer in two forms; one containing a low cost, low power polarizer, the other a high performance, high power Glan prism. Extinction as high as -40dB (10^{-4}) is possible using the 720 Glan with a small beam and a properly tuned Faraday rotator. Extinction with the low power type ranges between -20 and -30dB . Both types are fully rotatable.

The polarization of light reflected back towards the laser source may not be the same as that in the forward direction. Any orthogonal polarization component accidentally produced will not be rejected by the polarizer-rotator combination shown in Figure 1. A second polarizer must be added to the assembly on the opposite end of the rotator and aligned at 45° to the original polarizer. This allows the forward beam to proceed with only the additional static loss of the second polarizer ($<4\%$) but eliminates the unwanted polarization component in the backward direction. The modular design of 700 Series components provides for convenient mounting of polarizer's to either end of rotator assemblies.

ConOptics, Inc. 19 Eagle Road, Danbury, CT 06810 Phone 800-748-3349 Fax 203-790-6145
Contact: sales@conoptics.com, Website: www.conoptics.com

Quartz Compensators

A frequently annoying feature of optical isolators is that the polarization of the forward transmitted beam is at 45° to that of the source. Addition of a Model 730 Compensator provides a net rotation of either 0° or 90°, selectable by interchanging output and input ends of the assembly. The 730's utilize the rotary power of Z cut crystal quartz as fixed 45° elements. The effect on a transmitted polarization form is the same as that of a Faraday rotator except it is fully reciprocal. An additional advantage of the 730 is that it partially achromatizes the isolator, an important benefit when dealing with broadband or tunable lasers. A good approximation of the wavelength dependence of a Faraday rotator tuned to a 45° at λ_0 is

$$2) \Theta_F = \pm 45^\circ \frac{\lambda^2}{\lambda_0^2} \left(\frac{\lambda_0^2 - F}{\lambda^2 - F} \right)^2$$

Where F is a constant peculiar to the type of glass used and λ_0 . The sense of the rotation (\pm) is dependent on the direction of propagation. The rotation of the 730 compensator (45° at λ_0) is expressed similarly,

$$3) \Theta_C = 45^\circ \frac{\lambda^2}{\lambda_0^2} \left(\frac{\lambda_0^2 - C}{\lambda^2 - C} \right)^2$$

but the sense is independent of propagation direction. The net rotation of these elements in series is

$$4) \Theta = \Theta_C + \Theta_F = 45^\circ \frac{\lambda^2}{\lambda_0^2} \left[\left(\frac{\lambda_0^2 - C}{\lambda^2 - C} \right)^2 \pm \left(\frac{\lambda_0^2 - F}{\lambda^2 - F} \right)^2 \right]$$

Figure 2 is an 800 - 1000 nm plot of equation 4 using a Model 714 Faraday rotator and Model 730 Compensator between two polarizer's. In this case λ_0 is 880 nm. Ideal components are assumed and static losses are not shown. For the sake of comparison, an uncompensated rotator between two polarizer's is also shown. The 714/730 combination configured to produce a 0° net forward rotation at λ_0 (Parallel polarizer's) offers nearly lossless transmission across the wavelength band.

ConOptics, Inc. 19 Eagle Road, Danbury, CT 06810 Phone 800-748-3349 Fax 203-790-6145
Contact: sales@conoptics.com, Website: www.conoptics.com

Extinction of reflected light, however, degrades rapidly towards the band edges. On the other hand, the configuration which produces a 90° rotation at λ_0 in the forward direction (crossed polarizer's) shows a high extinction across the band with only a modest reduction of transmission towards the band edges. This means moderate wavelength changes can be made without re-adjusting the isolator. Conversion between one configuration and the other is accomplished simply by turning the entire assembly end for end and adjusting the polarizers between the crossed and parallel positions.

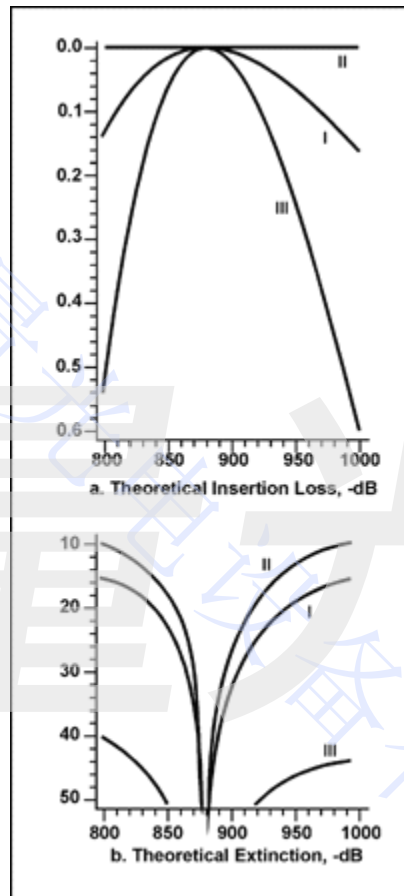

FIGURE 2: Insertion loss and extinction vs. wavelength (nm).
 I, uncompensated; II, 0° rotation compensated; III, 90° rotation compensated.
 Models 714 and 730, $\lambda_0 = 880\text{nm}$. Static losses are not included.

ConOptics, Inc. 19 Eagle Road, Danbury, CT 06810 Phone 800-748-3349 Fax 203-790-6145
 Contact: sales@conoptics.com, Website: www.conoptics.com

The Model 716

Certain lasers (e.g. diode lasers) are highly susceptible to the disturbing influences of back reflections and the -30 to -40dB isolation provided by Models 711A through 715 is inadequate. The Model 716 is specifically designed for such applications. Referring to Figure 3, it is seen to consist of two Faraday elements and three polarizer's. Only the center polarizer, P2, is rotatable about the beam axis. The Faraday elements are identical except for the magnetic field direction reversal so that, disregarding the effect of P2, their rotations cancel.

Assuming that forward propagating light entering P1 from the left is linearly polarized and well aligned to the transmission direction (0°) of P1, the transmission of the assembly is given by

$$5) T_F = \text{Cos}^4 (\theta_F - \varphi)$$

Where Q_F is the rotation due to each Faraday element and F is the orientation of P2. Similarly, the assembly transmission of backward propagating light is

$$6) T_B = \text{Cos}^4 (\theta_F + \varphi)$$

Since the purpose of the device is to prevent back reflections, φ is tuned to make $T_B = 0$, that is, $\theta_F + \varphi = 90^\circ$. Substituting in Equation 5,

$$7) T_F = \text{Cos}^4 (2\theta_F - 90^\circ) = \text{Sin}^4 (2\theta_F)$$

Equation 2 shows how θ_F varies with deviations from the peak wavelength, λ_0 . Equation 7 shows that as θ_F varies from 45° and φ is tuned to maintain high backward extinction, the forward transmission is reduced. Figure 4 is a plot of the forward transmission of Model 716 as the center polarizer is rotated for best backward extinction at wavelengths near the peak wavelength of 823 nm. Since the 716 is supplied complete with three polarizers, all static losses are included. The peak wavelength of Model 716 can be factory adjusted to any wavelength within the range 600 to 850nm.

ConOptics, Inc. 19 Eagle Road, Danbury, CT 06810 Phone 800-748-3349 Fax 203-790-6145
Contact: sales@conoptics.com, Website: www.conoptics.com

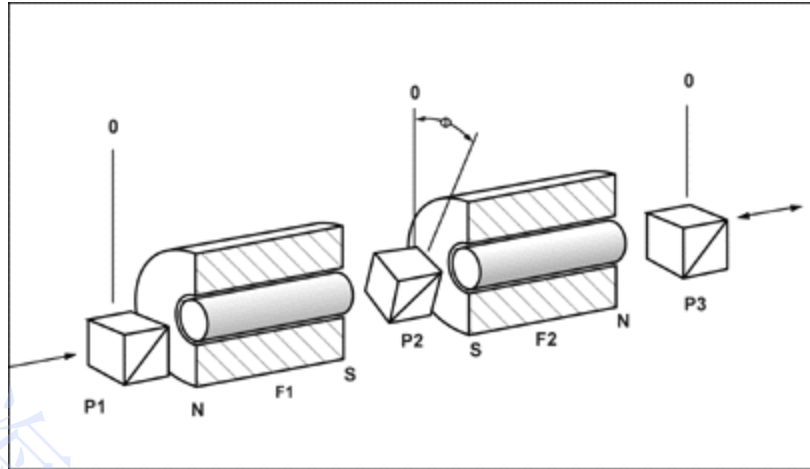

FIGURE 3: Model 716 internal construction. P1, P2, and P3 are polarizer's, F1 and F2 are Faraday rotators.

Equations 6 and 7 represent ideal components. In general, however, the residual imperfections of both Faraday rotators and polarizer's limit extinction of back reflected light. The tandem configuration of the Model 716 effectively halves the leakage (in dB) due to radial field gradients and glass imperfections in the Faraday elements thereby making extinction of the polarizer's the limiting factor. A crossed pair of Conoptics Glan polarizer's exhibits an extinction of approximately -60dB (a transmission ratio of 10^{-6}). The residual leakage is caused by surface and bulk scattering and spurious birefringence. On average, the leakage can be considered to be unpolarized and the third polarizer adds only another -3dB to the extinction. Careful manufacturing and selection procedures assure that an extinction of at least -60dB can be achieved and maintained with the Model 716.

ConOptics, Inc. 19 Eagle Road, Danbury, CT 06810 Phone 800-748-3349 Fax 203-790-6145
 Contact: sales@conoptics.com, Website: www.conoptics.com

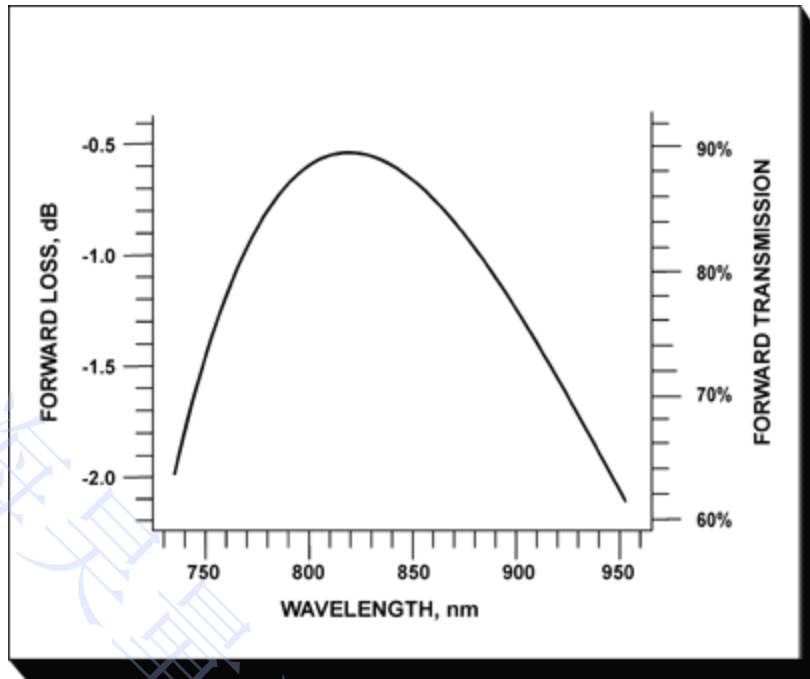

FIGURE 4: Forward transmission as a function of wavelength for best isolation for a Model 716 peaked at 823nm (-1dB range is 110nm centered at 830nm). All static losses are included.

ConOptics, Inc. 19 Eagle Road, Danbury, CT 06810 Phone 800-748-3349 Fax 203-790-6145
Contact: sales@conoptics.com, Website: www.conoptics.com

Tuning Ranges

700 SERIES OPTICAL ISOLATOR TUNING RANGES			
MODEL NUMBER	TUNING RANGE	ISOLATION	TRANSMISSION
711A	500 TO 645	37 → 40dB	92%
711C	390 TO 500	28 → 30dB	85%
712A	532 TO 715	37 → 40dB	92%
712B	644 TO 780	37 → 40dB	92%
712TGG	700 TO 900	37 → 40dB	92%
713A	650 TO 900	37 → 40dB	92%
713B	790 TO 980	37 → 40dB	92%
714A	780 TO 1000	37 → 40dB	92%
715	965 TO 1135	37 → 40dB	92%
716 (DOUBLE)	SPECIFY CENTER λ	56 → 60dB	88%
716TGG	1064	56 → 60dB	88%

All isolators are supplied with (2) Glan type polarizer's with double escape points and mounting base.

All have 5.0 mm Aperture

ConOptics, Inc. 19 Eagle Road, Danbury, CT 06810 Phone 800-748-3349 Fax 203-790-6145
Contact: sales@conoptics.com, Website: www.conoptics.com

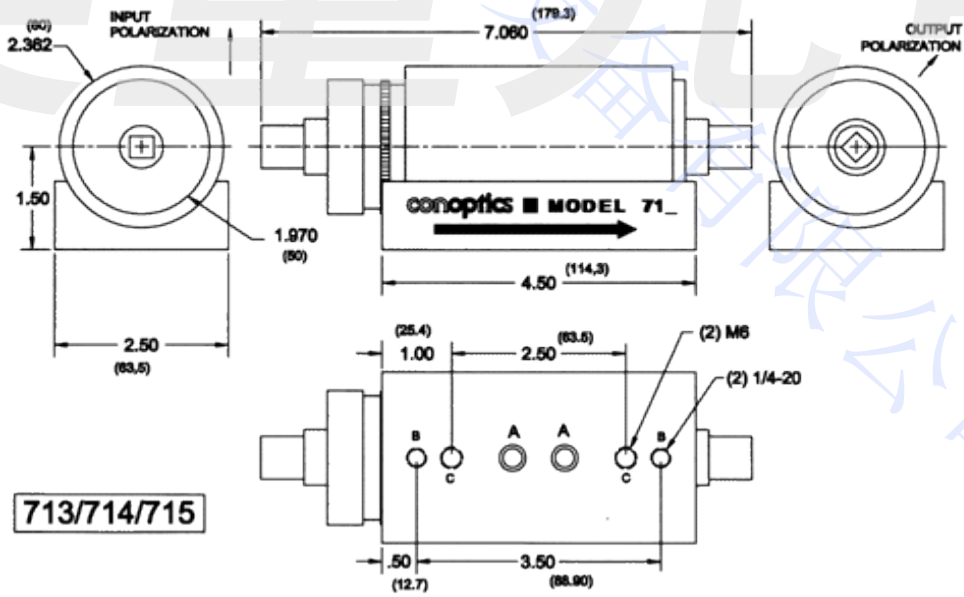
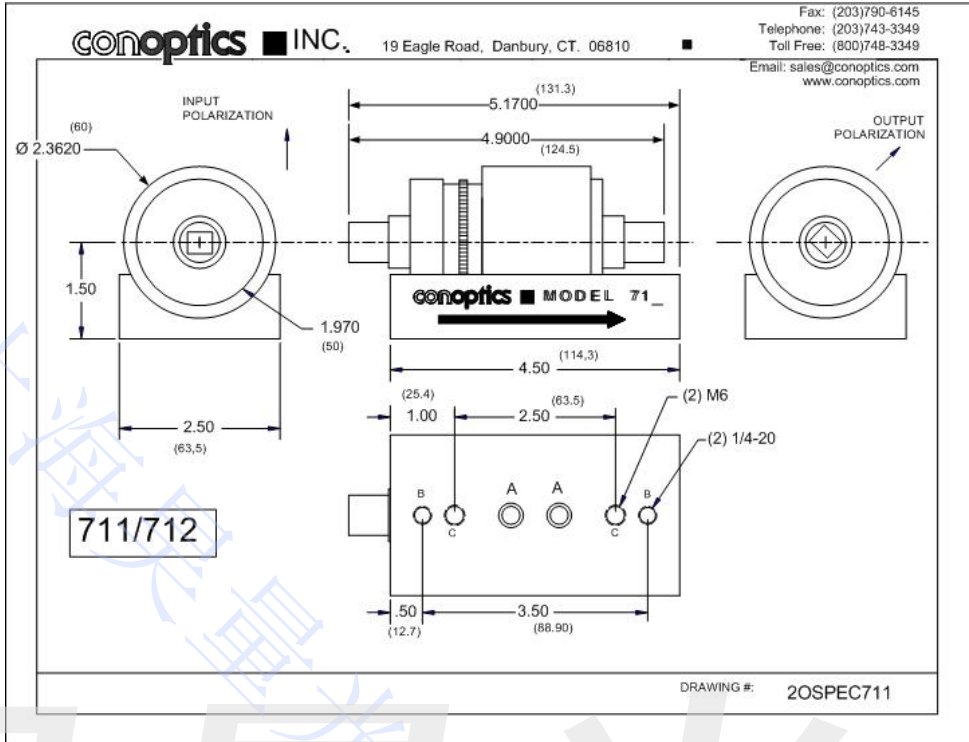

ConOptics, Inc. 19 Eagle Road, Danbury, CT 06810 Phone 800-748-3349 Fax 203-790-6145
 Contact: sales@conoptics.com, Website: www.conoptics.com

OUTLINE DIMENSIONS: MODEL 716

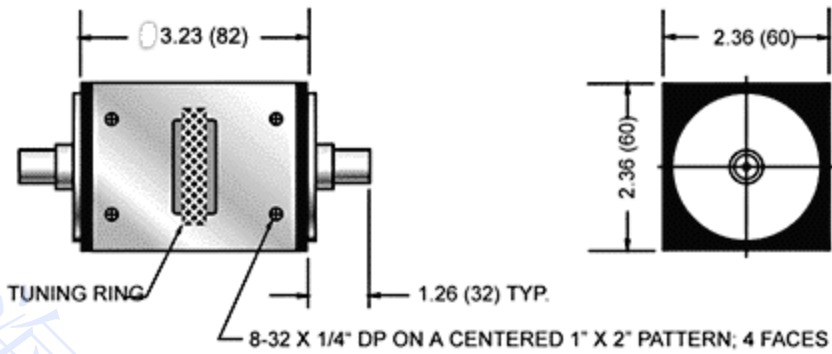

昊量光电

ConOptics, Inc. 19 Eagle Road, Danbury, CT 06810 Phone 800-748-3349 Fax 203-790-6145
Contact: sales@conoptics.com, Website: www.conoptics.com