

### Air Bearing



MAX. AXIAL LOAD	N	137
MAX. RADIAL LOAD	N	51
AXIAL STIFFNESS	N/μm*	68
RADIAL STIFFNESS	N/μm*	25
TILT STIFFNESS	Nm/mrad*	33
RAD. ERR. MOTION	nm LSC***	< 100
AXIAL ERR. MOTION	nm LSC***	< 50
WOBBLE	arcsec	typical**
AIR CONSUMPTION	NL/min	< 4
TOTAL MASS	kg	0,6
ANGULAR ACCURACY	arcsec	± 13,8
MATERIAL		coated aluminium

### Motor & Encoder

NOMINAL TORQUE	Nm	0,04
PEAK TORQUE	Nm	0,13
MAX. SPEED	rpm	300
ENCODER	periods	11840
ENCODER RESOLUTION	arcsec	go to p. 13
REPEATABILITY	arcsec	resolution x2

# RT075S

All data valid at 5 bar air pressure.

\* Tolerance on value +/- 20%

\*\* Measurement report of the wobble error motion can be provided on request.

\*\*\* Error motion measured on spherical artefact with center at 75 mm above top surface.

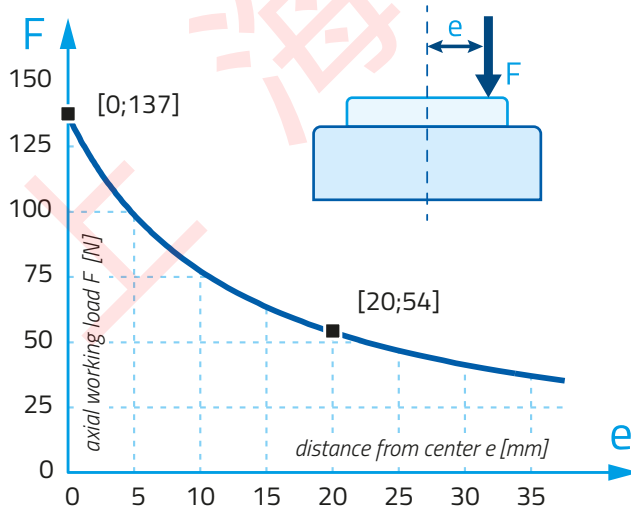

Max. working load vs. eccentricity

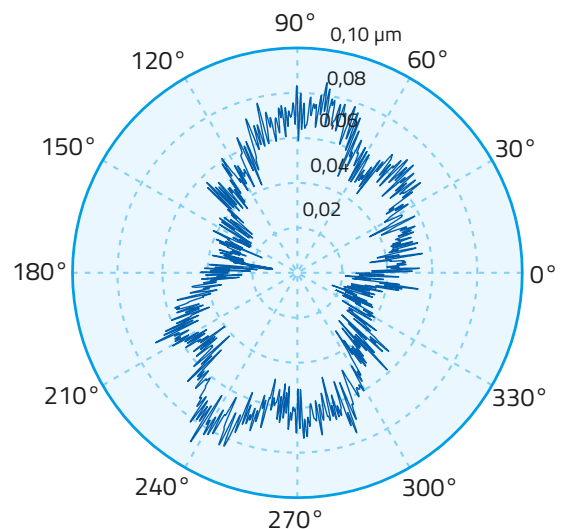

Roundness

error motion (typical value): LSC Δr = 78,6 nm  
filter: 360 UPR, 1 revolution (9,6 rpm)



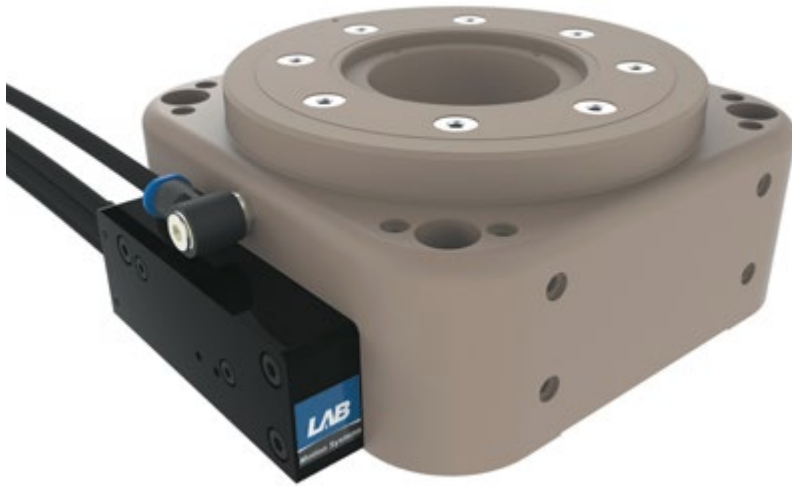

## Air Bearing



MAX. AXIAL LOAD	N	206
MAX. RADIAL LOAD	N	78
AXIAL STIFFNESS	N/μm*	103
RADIAL STIFFNESS	N/μm*	39
TILT STIFFNESS	Nm/mrad*	90
RAD. ERR. MOTION	nm LSC***	< 100
AXIAL ERR. MOTION	nm LSC***	< 50
WOBBLE	arcsec	typical**
AIR CONSUMPTION	NL/min	< 8
TOTAL MASS	kg	1,6
ANGULAR ACCURACY	arcsec	± 10,3
MATERIAL		coated aluminium

## Motor & Encoder

NOMINAL TORQUE	Nm	0,13
PEAK TORQUE	Nm	0,40
MAX. SPEED	rpm	200 - 1200
ENCODER	periods	15744
ENCODER RESOLUTION	arcsec	go to p. 13
REPEATABILITY	arcsec	resolution x2

# RT100S

All data valid at 5 bar air pressure.

\* Tolerance on value +/- 20%

\*\* Measurement report of the wobble error motion can be provided on request.

\*\*\* Error motion measured on spherical artefact with center at 111 mm above top surface.

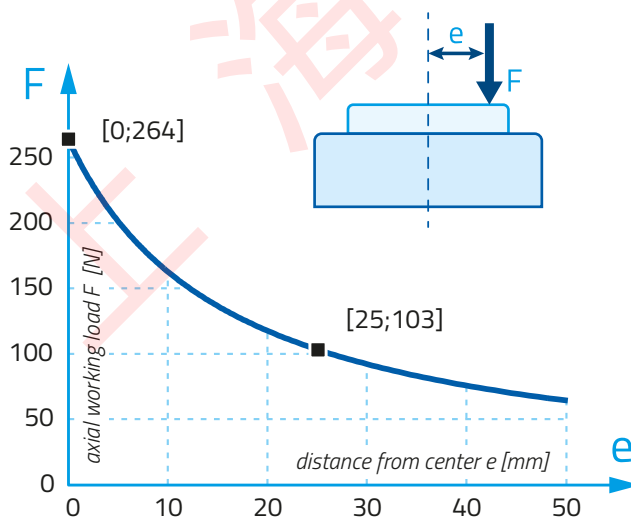

Max. working load vs. eccentricity

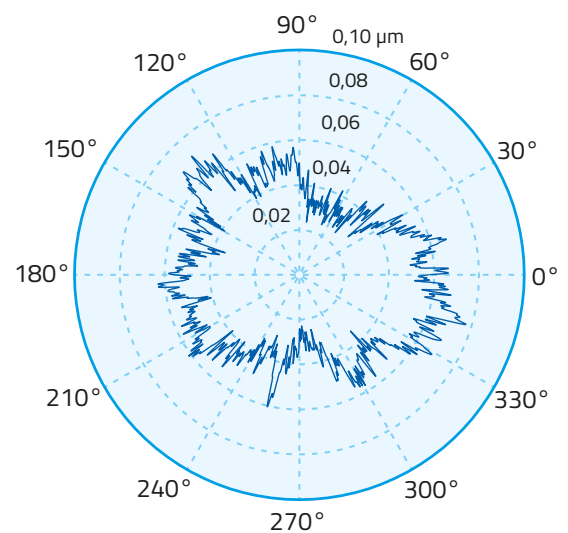

Roundness

error motion (typical value): LSC  $\Delta r = 52,9$  nm  
filter: 360 UPR, 1 revolution (9,6 rpm)

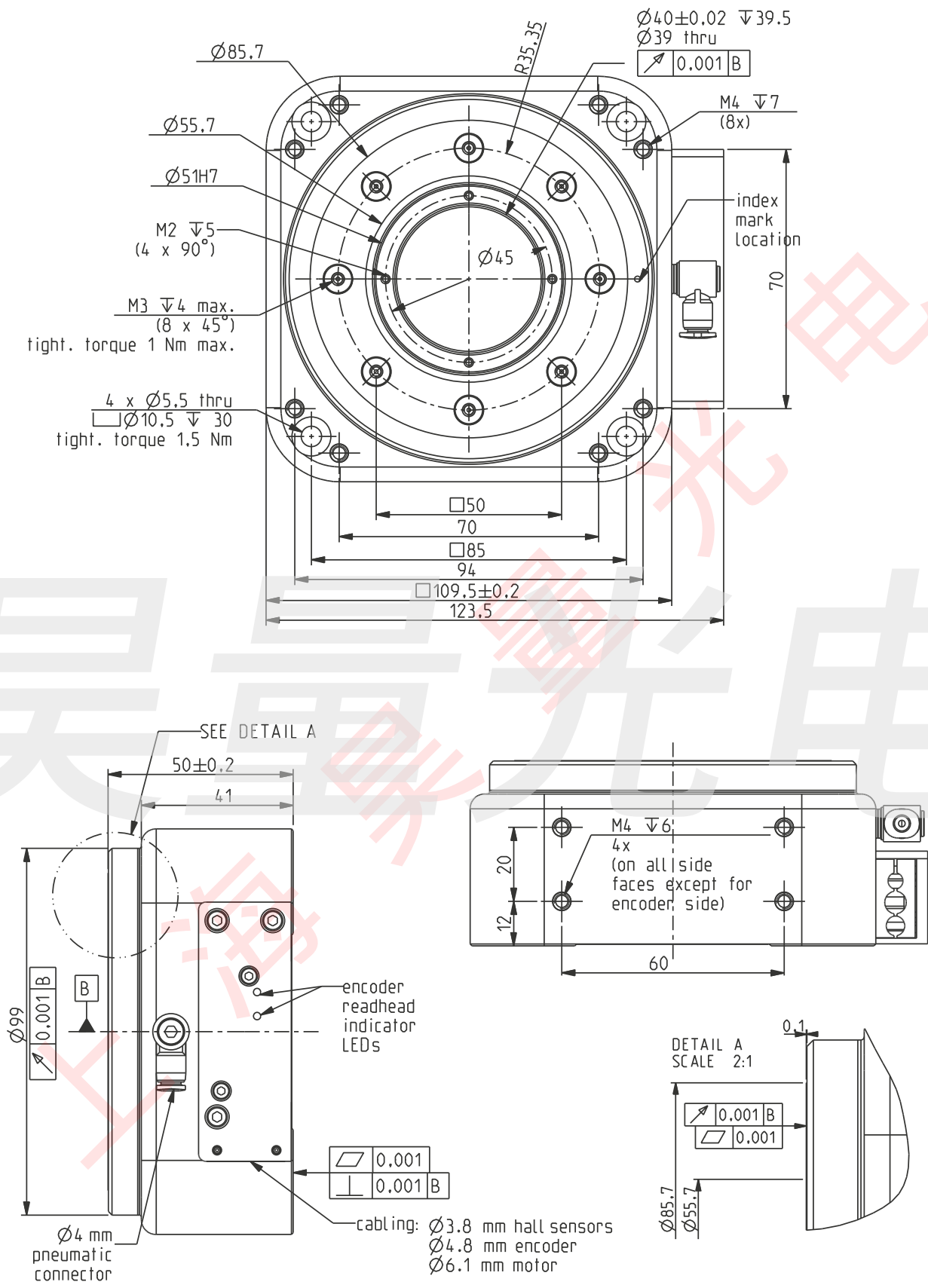

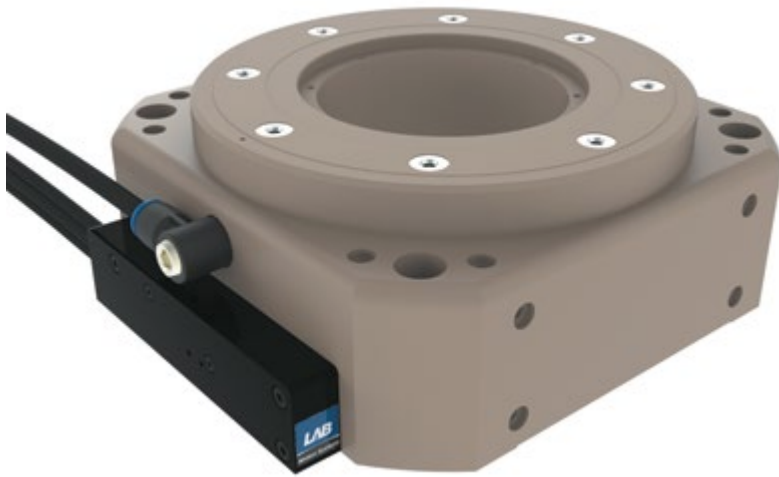

## Air Bearing



MAX. AXIAL LOAD	N	434
MAX. RADIAL LOAD	N	226
AXIAL STIFFNESS	N/μm*	217
RADIAL STIFFNESS	N/μm*	113
TILT STIFFNESS	Nm/mrad*	455
RAD. ERR. MOTION	nm LSC***	< 100
AXIAL ERR. MOTION	nm LSC***	< 50
WOBBLE	arcsec	typical**
AIR CONSUMPTION	NL/min	< 10
TOTAL MASS	kg	4,0
ANGULAR ACCURACY	arcsec	± 6,9
MATERIAL		coated aluminium

## Motor & Encoder

NOMINAL TORQUE	Nm	0,45
PEAK TORQUE	Nm	1,35
MAX. SPEED	rpm	200 - 800
ENCODER	periods	23600
ENCODER RESOLUTION	arcsec	go to p. 13
REPEATABILITY	arcsec	resolution x2

# RT150S

All data valid at 5 bar air pressure.

\* Tolerance on value +/- 20%

\*\* Measurement report of the wobble error motion can be provided on request.

\*\*\* Error motion measured on spherical artefact with center at 106 mm above top surface.

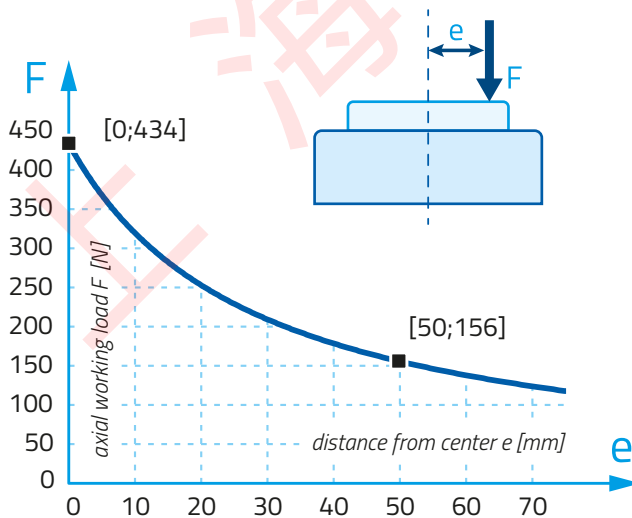

Max. working load vs. eccentricity

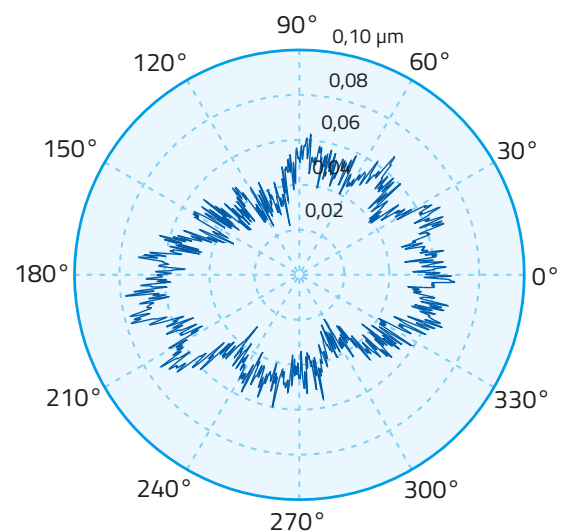

Roundness

error motion (typical value): LSC  $\Delta r = 54,8$  nm  
filter: 360 UPR, 1 revolution (9,6 rpm)

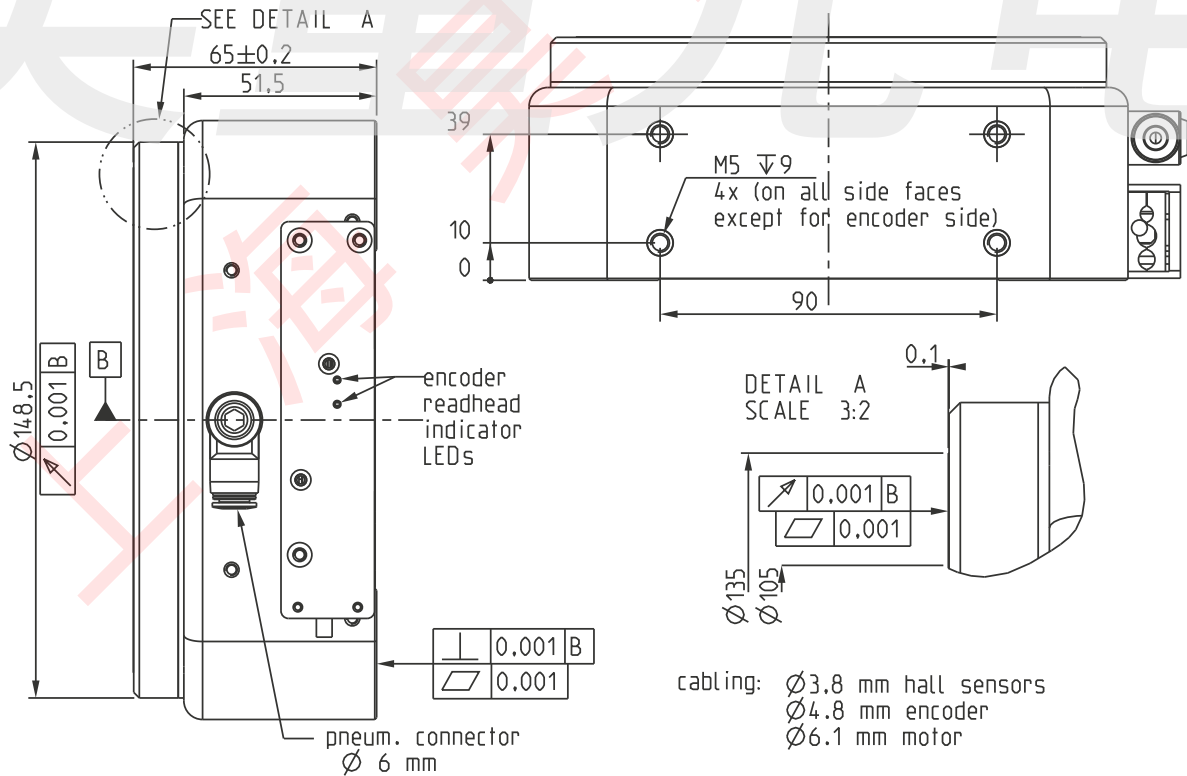
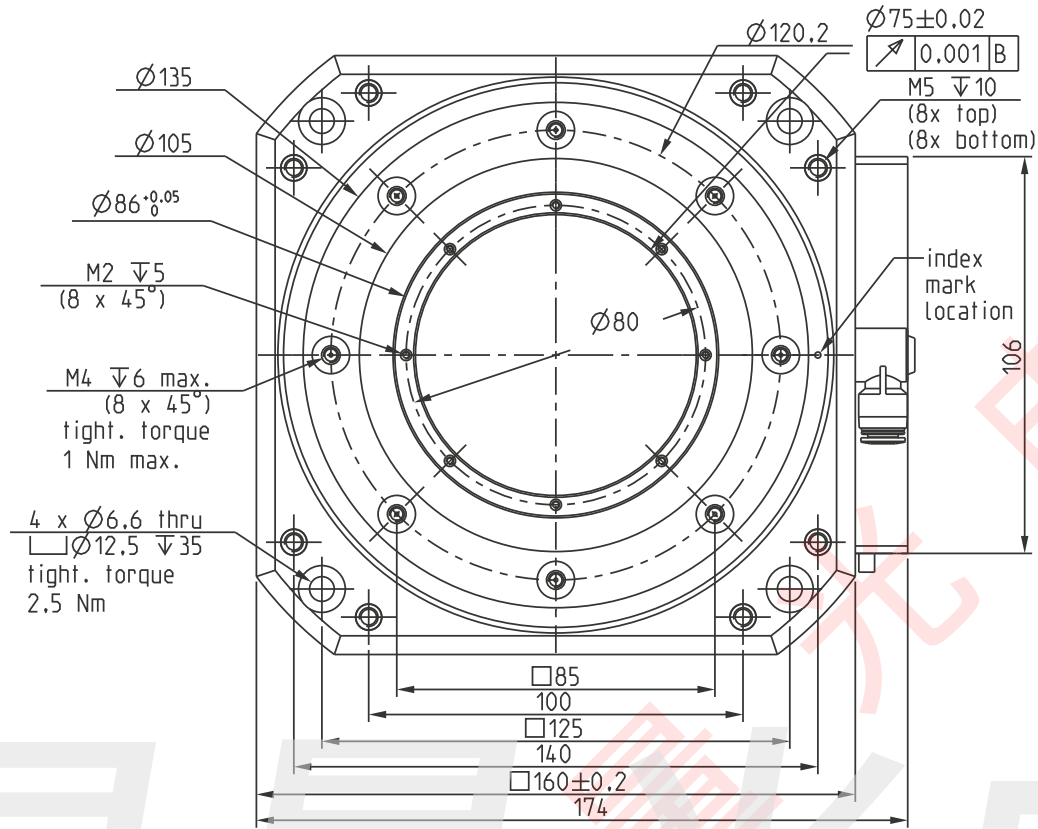

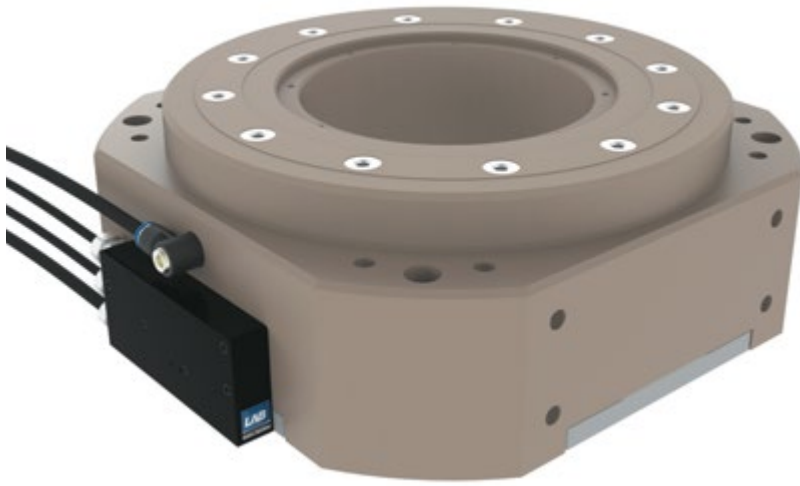

## Air Bearing

MAX. AXIAL LOAD	N	804
MAX. RADIAL LOAD	N	452
AXIAL STIFFNESS	N/ $\mu\text{m}^*$	402
RADIAL STIFFNESS	N/ $\mu\text{m}^*$	226
TILT STIFFNESS	Nm/mrad*	2380
RAD. ERR. MOTION	nm LSC***	< 100
AXIAL ERR. MOTION	nm LSC***	< 50
WOBBLE	arcsec	typical**
AIR CONSUMPTION	NL/min	< 15
TOTAL MASS	kg	16,5
ANGULAR ACCURACY	arcsec	$\pm 4,0$
MATERIAL		coated aluminium

## Motor & Encoder

NOMINAL TORQUE	Nm	1,5
PEAK TORQUE	Nm	4,5
MAX. SPEED	rpm	120
ENCODER	periods	40000
ENCODER RESOLUTION	arcsec	go to p. 13
REPEATABILITY	arcsec	resolution x2

# RT250S

All data valid at 5 bar air pressure.

\* Tolerance on value +/- 20%

\*\* Measurement report of the wobble error motion can be provided on request.

\*\*\* Error motion measured on spherical artefact with center at 146 mm above top surface.

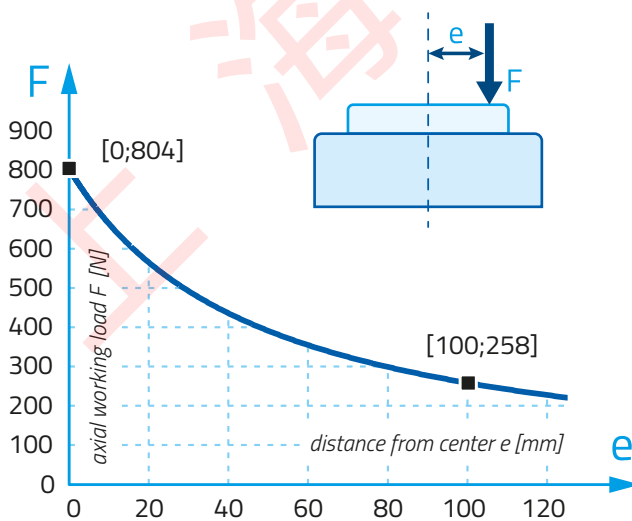

Max. working load vs. eccentricity

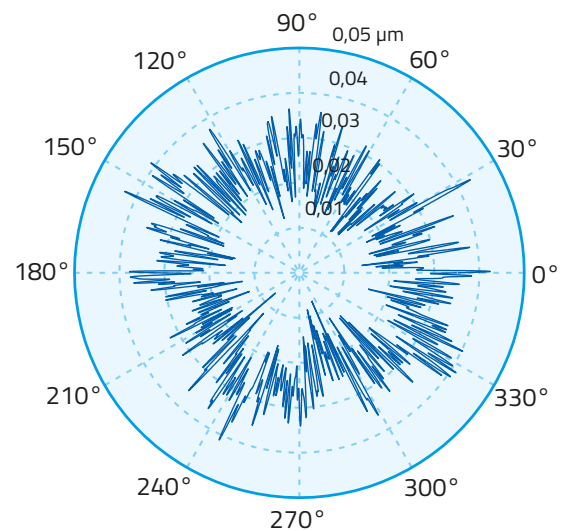

Roundness

error motion (typical value): LSC  $\Delta r = 36,6$  nm  
filter: 360 UPR, 1 revolution (9,6 rpm)

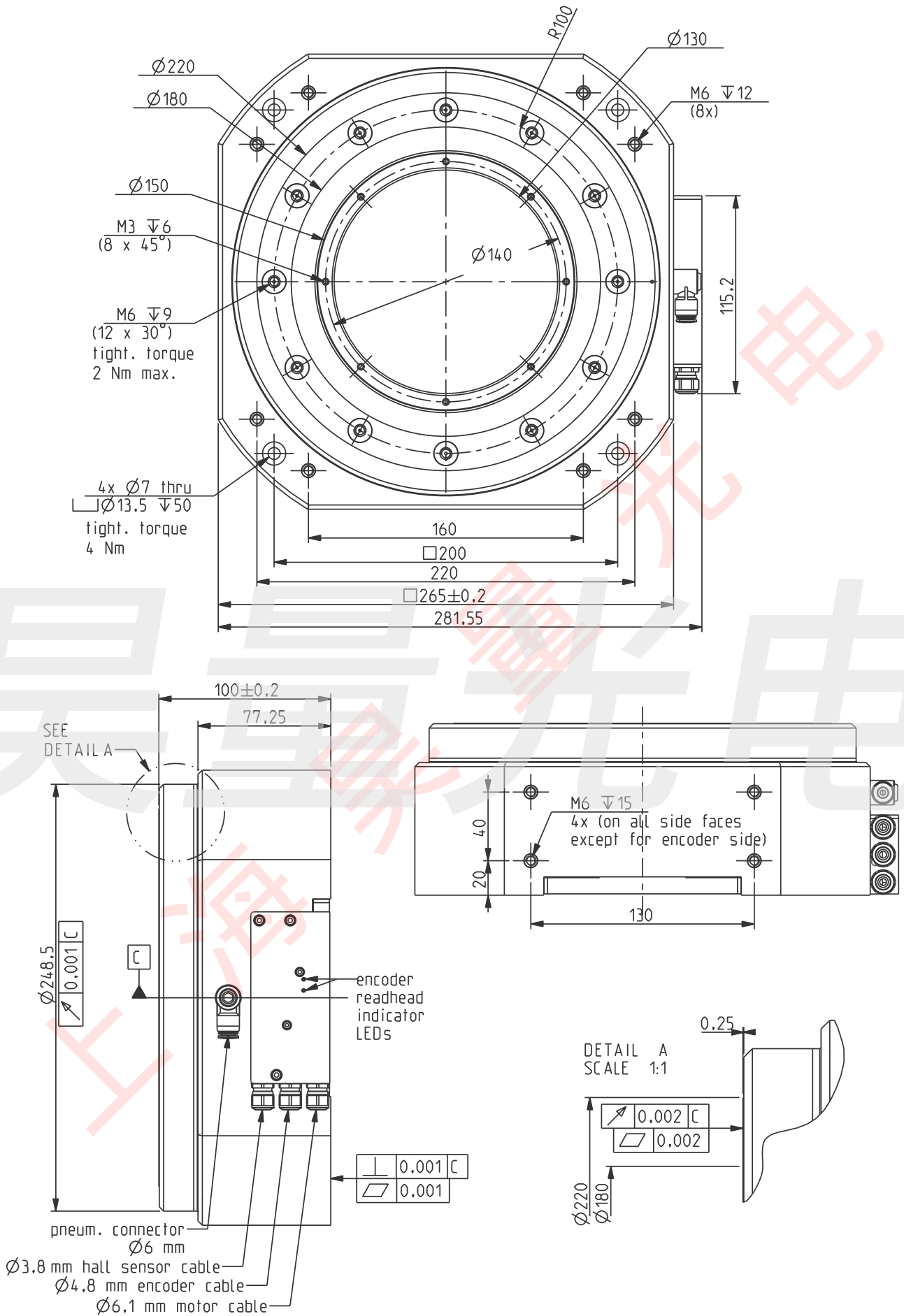

Required flatness for mounting surfaces is 1  $\mu$ m (rotor and stator).  
 Contact LAB Motion Systems support for advice on side-mounting requirements.



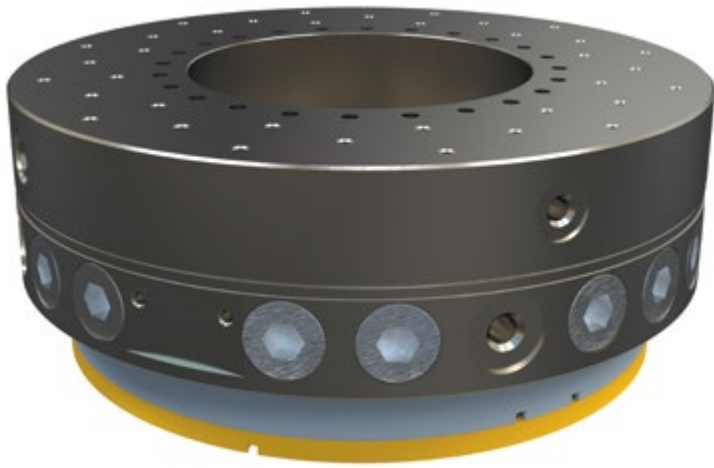

## Air Bearing

MAX. AXIAL LOAD	N	8300
MAX. RADIAL LOAD	N	2570
MAX. TILT LOAD	Nm	748
AXIAL STIFFNESS	N/μm*	1660
RADIAL STIFFNESS	N/μm*	514
TILT STIFFNESS	Nm/μrad*	37,4
RAD. ERR. MOTION	nm LSC***	< 100
AXIAL ERR. MOTION	nm LSC***	< 50
WOBBLE	arcsec	typical**
AIR CONSUMPTION	NL/min	< 100
TOTAL MASS	kg	175
ANGULAR ACCURACY	arcsec	± 2,9
MATERIAL		stainless steel

## Motor & Encoder

NOMINAL TORQUE	Nm	3,0
PEAK TORQUE	Nm	9,0
MAX. SPEED	rpm	60
ENCODER	periods	47200
ENCODER RESOLUTION	arcsec	go to p. 13
REPEATABILITY	arcsec	resolution x2

# RT500S

All data valid at 5 bar air pressure.

\* Tolerance on value +/- 20%

\*\* Measurement report of the wobble error motion can be provided on request.

\*\*\* Error motion measured on spherical artefact with center at 175 mm above top surface.

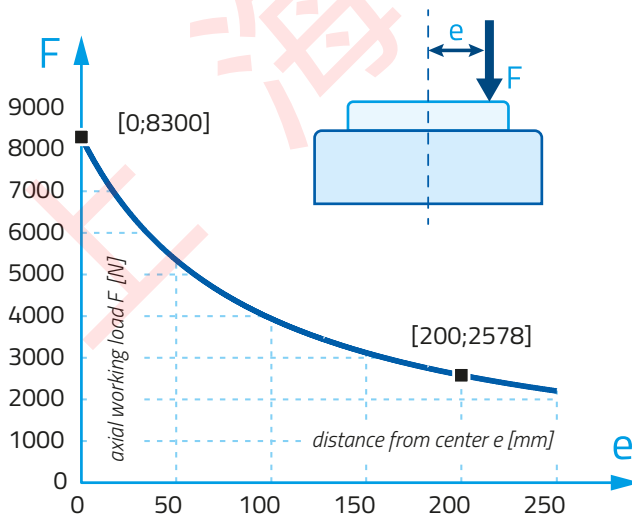

Max. working load vs. eccentricity

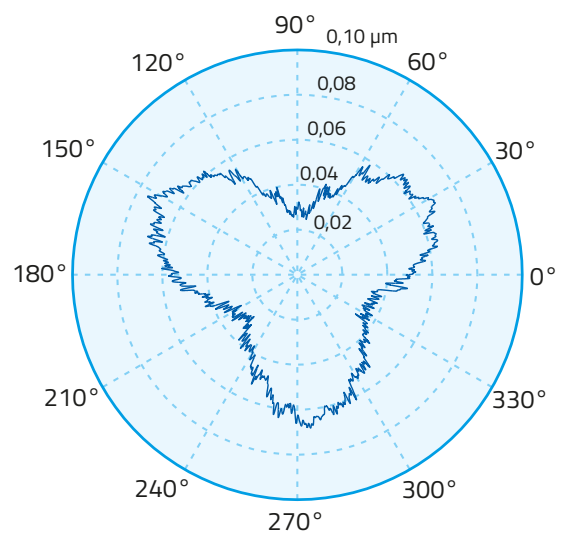

Roundness

error motion (typical value): LSC  $\Delta r = 50,1$  nm  
filter: 360 UPR, 1 revolution (9,6 rpm)

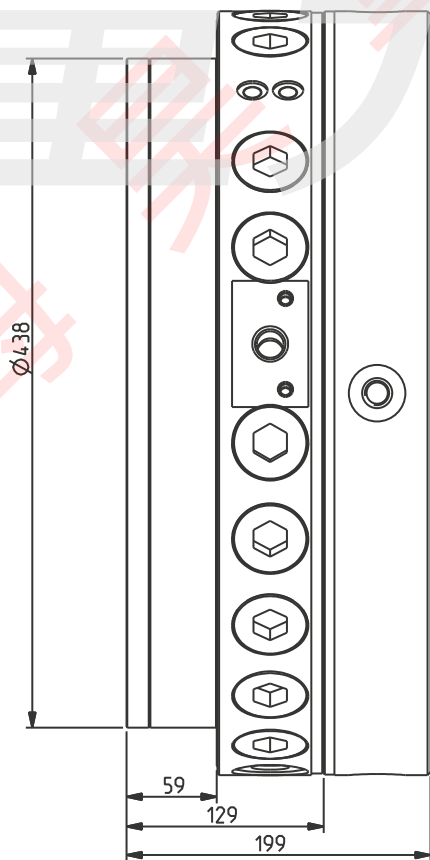
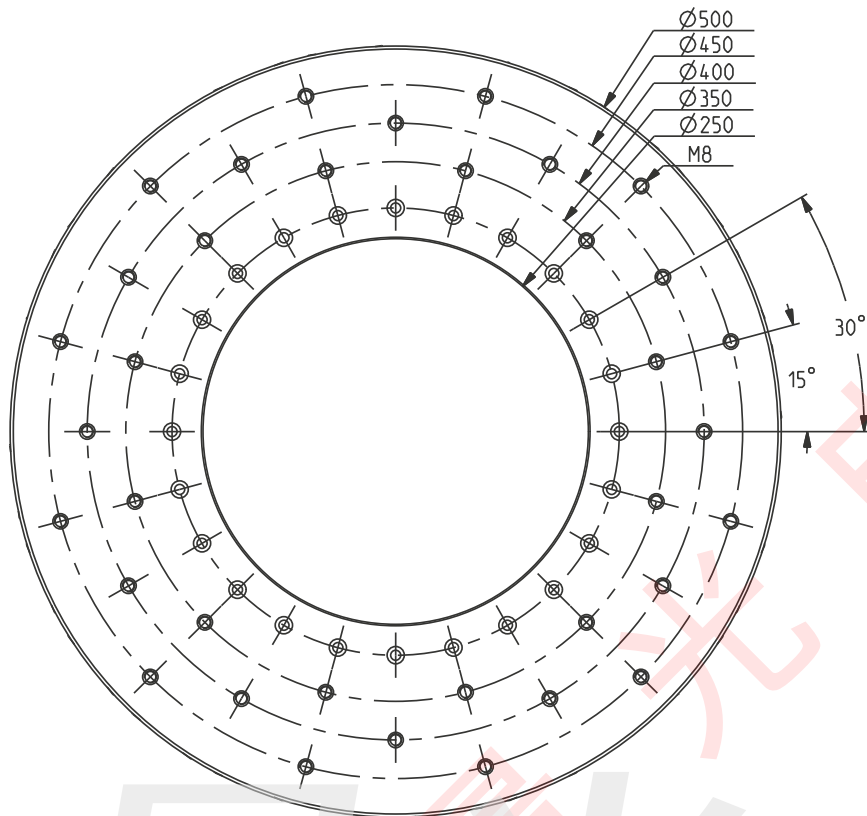

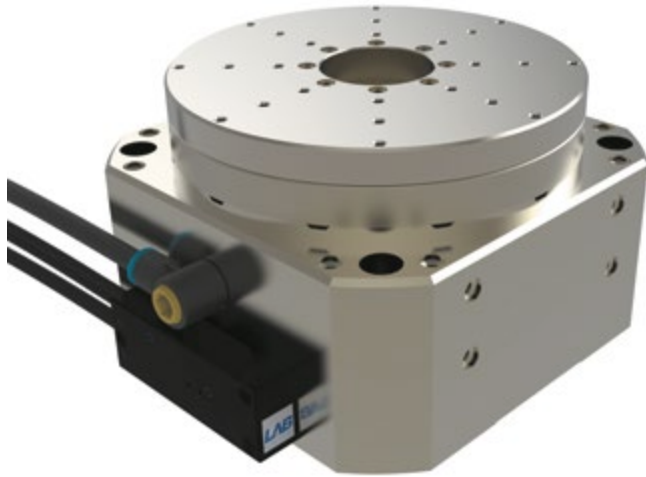

## Air Bearing



MAX. AXIAL LOAD	N	726
MAX. RADIAL LOAD	N	264
AXIAL STIFFNESS	N/μm*	242
RADIAL STIFFNESS	N/μm*	88
TILT STIFFNESS	Nm/mrad*	204
RAD. ERR. MOTION	nm LSC***	< 20
AXIAL ERR. MOTION	nm LSC***	< 20
WOBBLE	arcsec	typical**
AIR CONSUMPTION	NL/min	< 20
TOTAL MASS	kg	15,2
ANGULAR ACCURACY	arcsec	± 6,9
MATERIAL		stainless steel

## Motor & Encoder

NOMINAL TORQUE	Nm	0,5
PEAK TORQUE	Nm	1,5
MAX. SPEED	rpm	200
ENCODER	periods	23600
ENCODER RESOLUTION	arcsec	go to p. 13
REPEATABILITY	arcsec	resolution x2

# RT150U

All data valid at 5 bar air pressure.

\* Tolerance on value +/- 20%

\*\* Measurement report of the wobble error motion can be provided on request.

\*\*\* Error motion measured on spherical artefact with center at 95 mm above top surface.

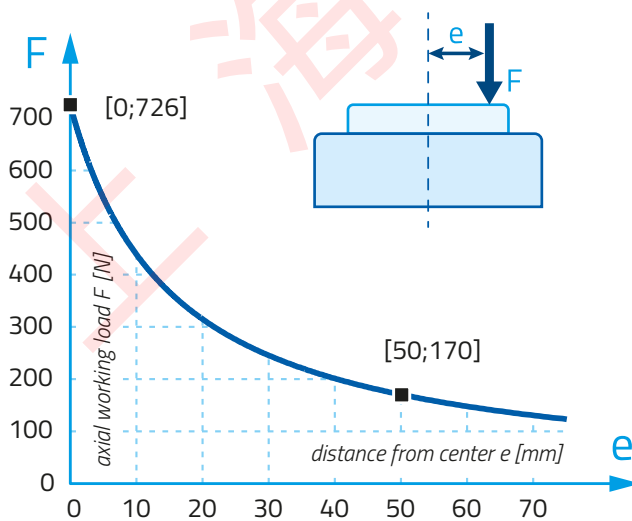

Max. working load vs. eccentricity

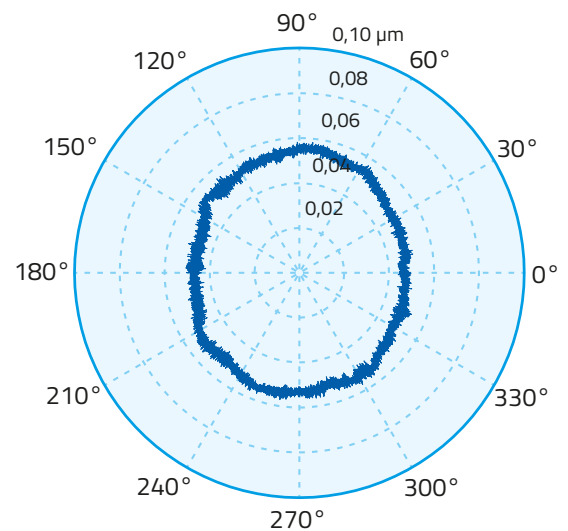

Roundness

error motion (typical value): LSC  $\Delta r = 16,6$  nm  
filter: none, 10 revolutions (2 rpm)

