

Laser Beam Profiling Solutions

昊量光电

UV/VIS/NIR Laser Beam Profiler

**CINOLOGY**  
TECHNOLOGIES

## TABLE OF CONTENTS

---

### PRODUCT DESCRIPTION

#### CINCAM CCD

- TECHNICAL DATA
- SENSOR RESPONSE
- DIMENSIONS

#### CINCAM CCD LARGE FORMAT

- TECHNICAL DATA
- SENSOR RESPONSE
- DIMENSIONS

#### CINCAM CMOS

- TECHNICAL DATA
- SENSOR RESPONSE
- DIMENSIONS

#### CINCAM CMOS NANO

- TECHNICAL DATA
- SENSOR RESPONSE
- DIMENSIONS

#### CINCAM CMOS PICO

- TECHNICAL DATA
- SENSOR RESPONSE
- DIMENSIONS

#### CINCAM INGAAS

- TECHNICAL DATA
- SENSOR RESPONSE
- DIMENSIONS

#### BEAM QUALITY M<sup>2</sup> - CINSQUARE

#### BEAM FOCUS MEASUREMENT - CINSPOT

#### LASER LINE CHARACTERIZATION - CINLINE

#### NEAR FIELD BEAM PROFILER - NFBP

#### ACCESSORIES

- NEUTRAL DENSITY FILTER
- BEAM REDUCER
- IR MODULE / SENSOR COATING
- UV SENSOR COATING
- PRISM ATTENUATOR

#### BEAM PROFILING SOFTWARE RAYCI



## CinCam CCD/CMOS/InGaAs - Product Description -

CINOGY Technologies CinCam is optimized to provide excellent sensitivity in the UV / VIS / NIR spectral range. Thanks to its high resolution and its small pixel size, the CinCam is a high performance tool for laser beam analysis of continuous wave (cw) and pulsed laser modes.

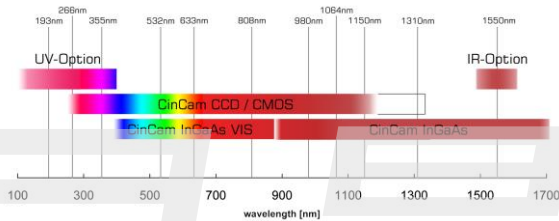

Spectral response:	<150nm - 1320nm / 900nm - 1800nm
Pixel size:	2.2 $\mu$ m <sup>2</sup> - 30.0 $\mu$ m <sup>2</sup>
Pixel:	0.1MPixel - 16MPixel
Technologies:	CCD / CMOS / InGaAs
Data output:	8Bit / 10Bit / 12Bit / 14Bit
Interface:	USB / FireWire / GigE

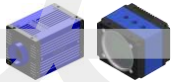

CinCam CCD  
CinCam CCD Large Format

CinCam CCD beam profilers enable high accuracy laser beam analysis from <150nm to 1150nm with best price/performance ratio. Due to its high dynamic range the CinCam captures even higher laser modes with outstanding detail. The passive cooled sensor is constructed without cover glass to avoid interference patterns.



CinCam CMOS  
CinCam CMOS-Nano  
CinCam CMOS-Pico

The particular cost-effective entry-level beam profiler CinCam CMOS is optimized to provide excellent sensitivity from <150nm to 1150nm (1320nm). The CMOS sensor is constructed without cover glass to avoid interference patterns. The lightweight and ultra-compact design facilitates easy integration in optical assemblies.



CinCam InGaAs

The CinCam InGaAs based on the latest InGaAs technology, allowing high sensitivity imaging in the range from 900nm to 1800nm. The 15 $\mu$ m/30 $\mu$ m square pixel beam profiler enables images with high dynamic range and resolution for accurate laser beam analysis.

The portable CinCam is designed to be used in a variety of applications in industry, science, R&D, including:

- Laser beam analysis of cw and pulsed lasers
- Quick control of laser modes and adjustment errors
- Test equipment for scientific research
- Near-Field and Far-Field analyses of lasers, LED devices and other light sources.

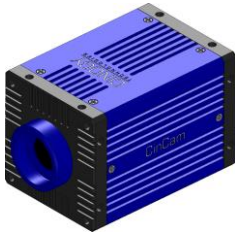

**CinCam CCD  
- Technical Data -**

	<b>CCD-1201</b>	<b>CCD-2301</b>	<b>CCD-2302</b>
	<i>Standard Series</i>	<i>Standard Series</i>	<i>Standard Series</i>
<b>SENSOR DATA</b>			
Format:	1/2"	2/3"	2/3"
Active area (without cover glass):	6.5mm x 4.8mm	9.0mm x 6.7mm	8.5mm x 7.1mm
Number of pixel:	1388 x 1038 (1.4MP)	1388 x 1038 (1.4MP)	2452 x 2056 (5MP)
Pixel size:	4.65µm x 4.65µm	6.45µm x 6.45µm	3.45µm x 3.45µm
Spectral response:			
Standard: absorptive built-in ND filter	400nm - 1150nm	400nm - 1150nm	400nm - 1150nm
RT: reflective built-in ND filter	320nm - 1150nm	320nm - 1150nm	320nm - 1150nm
UV: phosphor sensor coating	<150nm - 1150nm	<150nm - 1150nm	<150nm - 1150nm
OM: sensor without microlenses	-	-	-
IR: phosphor sensor coating	1470nm - 1605nm	1470nm - 1605nm	1470nm - 1605nm
Beam diameter min / max (recommended):	46.5µm / 4mm	64.5µm / 5mm	34.5µm / 5.5mm
Sensor cooling:	passive	passive	passive
<b>CAMERA FEATURES</b>			
Mount:	C-Mount	C-Mount	C-Mount
Bit depth (output):	14Bit (12Bit GigE)	14Bit (12Bit GigE)	14Bit (12Bit GigE)
Dynamic:	60dB (1:1000)	67dB (1:2200)	54dB (1:500)
Frame rate:	up to 15Hz	up to 16Hz	up to 6Hz
Exposure time:	500µs-300ms	500µs-300ms	500µs-300ms
Interface:	FireWire 1394b / GigE	FireWire 1394b / GigE	FireWire 1394b / GigE
I/O connector:	12-Pin Hirose	12-Pin Hirose	12-Pin Hirose
Mode:	cw or pulsed	cw or pulsed	cw or pulsed
Trigger:	TTL-Signal	TTL-Signal	TTL-Signal
<b>SPECIFICATIONS</b>			
Mechanical dimensions (W x H x L):	60mmx60mmx103.9mm	60mmx60mmx103.9mm	60mmx60mmx103.9mm
Weight:	300g	300g	300g
Electrical requirements:	DC 8V-36V	DC 8V-36V	DC 8V-36V
Storage temperature*:	-10°C...+60°C	-10°C...+60°C	-10°C...+60°C
Operating temperature*:	+5°C...+45°C	+5°C...+45°C	+5°C...+45°C
Regulations:	CE, RoHS	CE, RoHS	CE, RoHS

\* Without condensation

Design and specification of the described product(s) are subject to change without notice.

**CINOGY Technologies GmbH**  
Max-Näder-Str. 15 · 37115 Duderstadt · Germany  
Phone +49 5527 8483770 · Fax +49 5527 8483773  
e-mail info@cinogy.com · www.cinogy.com

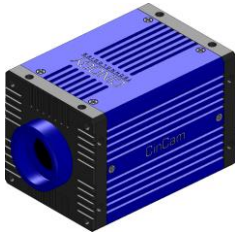

**CinCam CCD**  
**- Sensor Response -**  
**- Dimensions -**

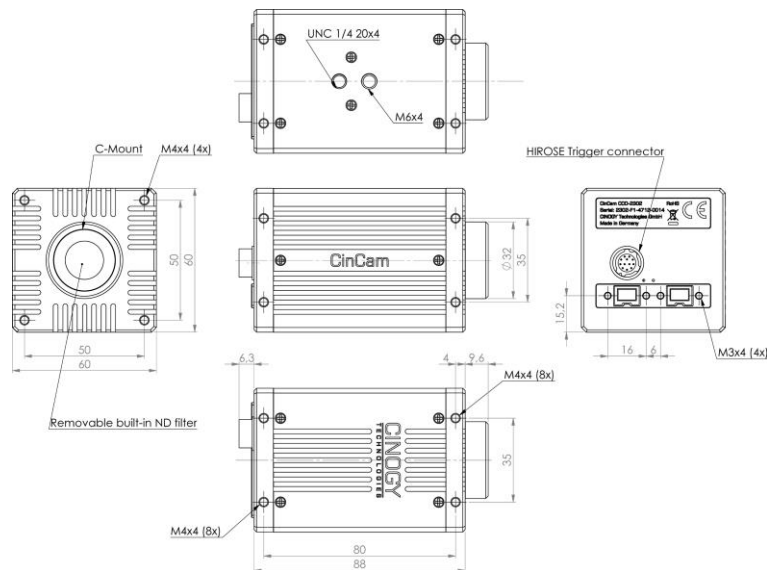
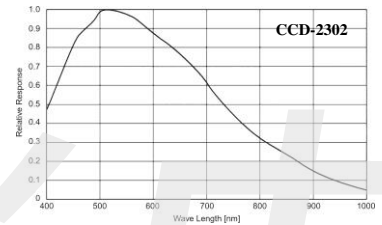
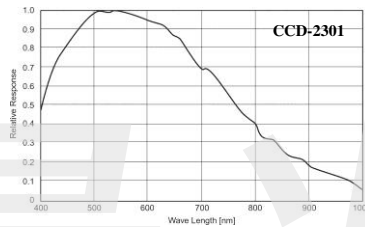
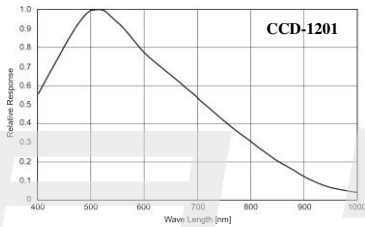

**CINOGY Technologies GmbH**  
Max-Näder-Str. 15 · 37115 Duderstadt · Germany  
Phone +49 5527 8483770 · Fax +49 5527 8483773  
e-mail info@cinogy.com · www.cinogy.com

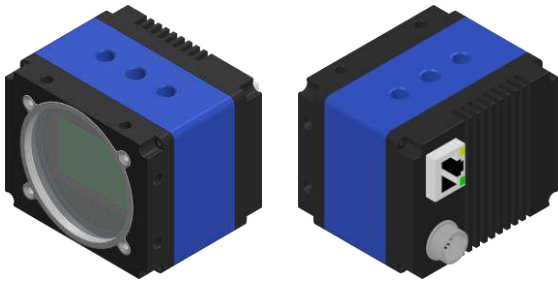

**CinCam CCD-3501**  
**- Technical Data -**

**CCD-3501**

*Large Format Series*

<b>SENSOR DATA</b>	
Format:	35mm CCD
Active area (without cover glass):	36mm x 24mm
Number of pixel:	4864 x 3232 (15.7MP)
Pixel size:	7.4µm x 7.4µm
Spectral response:	400nm - 1100nm
Beam diameter min / max (recommended):	74µm / 16mm
<b>CAMERA FEATURES</b>	
Mount:	Filter-Mount (M48x0.5)
Bit depth (output):	12Bit
Dynamic:	59dB (1:900)
Frame rate:	up to 2Hz@single tap; 4.6Hz@quad tap
Exposure time:	0.5ms-1s
Interface:	GigE
I/O connector:	12-Pin Hirose
Mode:	cw or pulsed
Trigger:	TTL-Signal
<b>SPECIFICATIONS</b>	
Mechanical dimensions (W x H x L):	66mmx53.3mmx59.1mm
Weight:	370g
Electrical requirements:	DC 7V-25V, PoE
Storage temperature*:	-10°C...+60°C
Operating temperature*:	+5°C...+45°C
Regulations:	CE, RoHS

\* Without condensation

Design and specification of the described product(s) are subject to change without notice.

**CINOGY Technologies GmbH**  
Max-Näder-Str. 15 · 37115 Duderstadt · Germany  
Phone +49 5527 8483770 · Fax +49 5527 8483773  
e-mail info@cinogy.com · www.cinogy.com

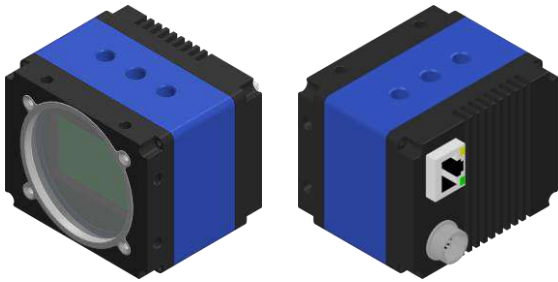

**CinCam CCD-3501**  
**- Sensor Response -**  
**- Dimensions -**

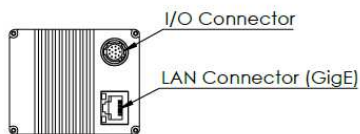
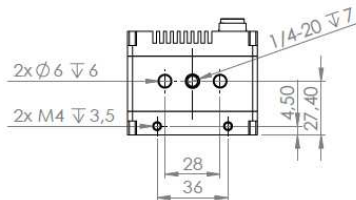
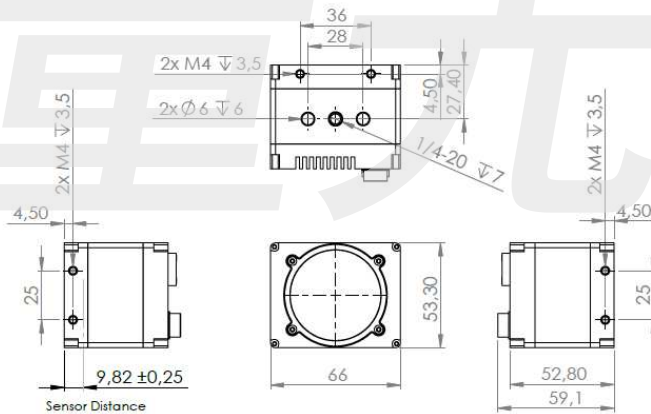
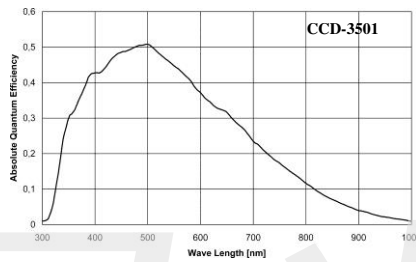

**CINOGY Technologies GmbH**  
Max-Näder-Str. 15 · 37115 Duderstadt · Germany  
Phone +49 5527 8483770 · Fax +49 5527 8483773  
e-mail info@cinogy.com · www.cinogy.com



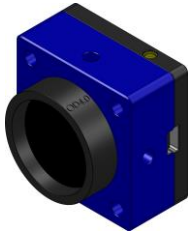

**CinCam CMOS  
- Technical Data -**

	<b>CMOS-1201</b>	<b>CMOS-1202</b>	<b>CMOS-1203</b>	<b>CMOS-1204</b>
	<i>Standard Series</i>	<i>Standard Series</i>	<i>Standard Series</i>	<i>Standard Series</i>
<b>SENSOR DATA</b>				
Format:	1/2"	1/1.8"	1/1.8"	1/2.5"
Active area (without cover glass):	6.7mm x 5.3mm	6.8mm x 5.4mm	7.2mm x 5.4mm	5.7mm x 4.3mm
Number of pixel:	1280 x 1024 (1.3MPixel)	1280 x 1024 (1.3MPixel)	1600 x 1200 (2MPixel)	2560 x 1920 (5MPixel)
Pixel size:	5.2µm x 5.2µm	5.3µm x 5.3µm	4.5µm x 4.5µm	2.2µm x 2.2µm
Spectral response:				
Standard:	absorptive built-in ND filter	400nm - 1150nm	400nm - 1320nm	400nm - 1150nm
RT:	reflective built-in ND filter	320nm - 1150nm	320nm - 1320nm	320nm - 1150nm
UV:	phosphor sensor coating	<150nm - 1150nm	<150nm - 1150nm	<150nm - 1150nm
OM:	sensor without microlenses	-	240nm - 1150nm	240nm - 1150nm
IR:	phosphor sensor coating	1470nm - 1605nm	1470nm - 1605nm	1470nm - 1605nm on request
Beam diameter min / max (recommended):	52µm / 4mm	53µm / 4.1mm	45µm / 4mm	22µm / 3.2mm
<b>CAMERA FEATURES</b>				
Mount:	Filter-Mount	Filter-Mount	Filter-Mount	Filter-Mount
Bit depth (output):	8Bit	8Bit	8Bit	8Bit
Dynamic:	68dB (1:2500)	62dB (1:1250)	62dB (1:1250)	70dB (1:3150)
Frame rate:	up to 20Hz	up to 20Hz	up to 14Hz	up to 5Hz
Exposure time:	100µs-140ms	100µs-300ms	100µs-300ms	200µs-200ms
Interface:	USB 2.0	USB 2.0	USB 2.0	USB 2.0
Shutter:	Rolling	Global	Global	Rolling
Mode:	cw	cw or pulsed	cw or pulsed	cw
Trigger:	-	TTL-Signal	TTL-Signal	-
<b>SPECIFICATIONS</b>				
Mechanical dimensions (W x H x L):	40mmx40mmx20mm	40mmx40mmx20mm	40mmx40mmx20mm	40mmx40mmx20mm
Weight:	46g	50g	50g	50g
Electrical requirements:	Power supply via USB	Power supply via USB	Power supply via USB	Power supply via USB
Storage temperature*:	-10°C...+60°C	-10°C...+60°C	-10°C...+60°C	-10°C...+60°C
Operating temperature*:	+0°C...+40°C	+0°C...+40°C	+0°C...+40°C	+0°C...+40°C
Regulations:	CE, RoHS	CE, RoHS	CE, RoHS	CE, RoHS

\* Without condensation

Design and specification of the described product(s) are subject to change without notice.

**CINOGY Technologies GmbH**  
Max-Näder-Str. 15 · 37115 Duderstadt · Germany  
Phone +49 5527 8483770 · Fax +49 5527 8483773  
e-mail info@cinogy.com · www.cinogy.com



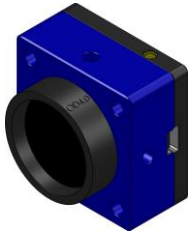

**CinCam CMOS**  
**- Sensor Response -**  
**- Dimensions -**

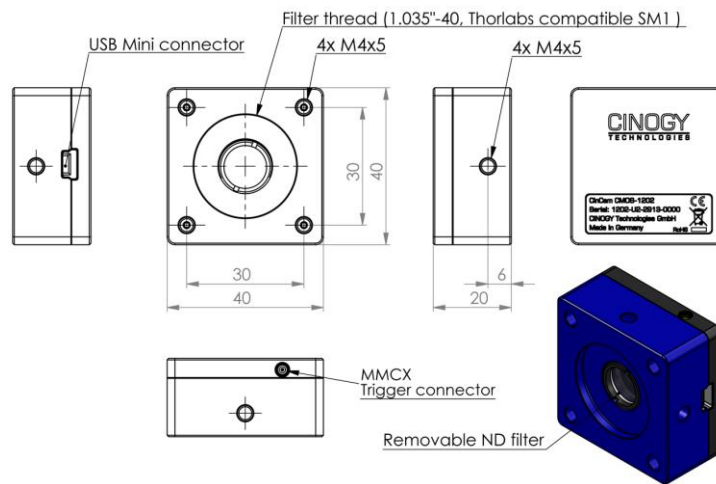
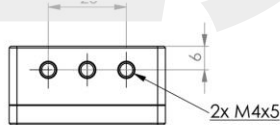
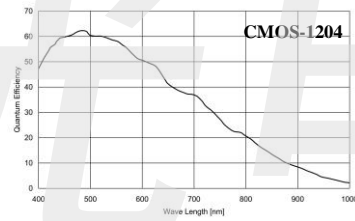
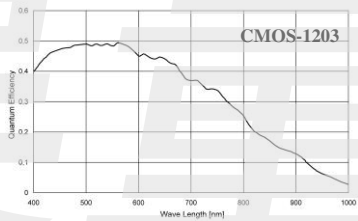
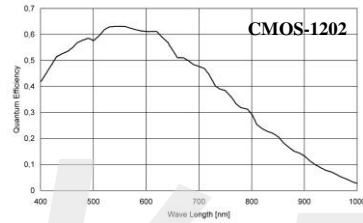
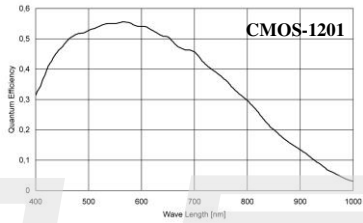

**CINOGY Technologies GmbH**  
Max-Näder-Str. 15 · 37115 Duderstadt · Germany  
Phone +49 5527 8483770 · Fax +49 5527 8483773  
e-mail info@cinogy.com · www.cinogy.com

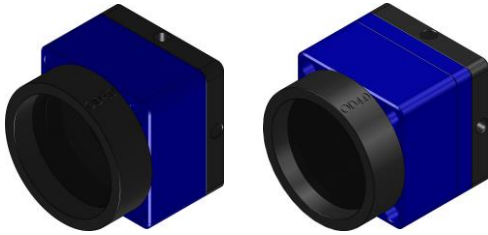

**CinCam CMOS Nano  
- Technical Data -**

	<b>CMOS-1201-Nano</b>	<b>CMOS-1.001-Nano</b>
	<i>Nano Series</i>	<i>Nano Series</i>
<b>SENSOR DATA</b>		
Format:	1/1.8"	1"
Active area (without cover glass):	6.8mm x 5.4mm	11.3mm x 11.3mm
Number of pixel:	1280 x 1024 (1.3MPixel)	2048 x 2048 (4.2MPixel)
Pixel size:	5.3µm x 5.3µm	5.5µm x 5.5µm
Spectral response:		
Standard: absorptive built-in ND filter	400nm - 1320nm	400nm - 1320nm
RT: reflective built-in ND filter	320nm - 1320nm	320nm - 1320nm
UV: phosphor sensor coating	<150nm - 1150nm	<150nm - 1150nm
OM: sensor without microlenses	240nm - 1150nm	240nm - 1150nm
IR: phosphor sensor coating	1470nm - 1605nm	1470nm - 1605nm
Beam diameter min / max (recommended):	53µm / 4.1mm	55µm / 7.5mm
<b>CAMERA FEATURES</b>		
Mount:	Filter-Mount	Filter-Mount
Bit depth (output):	10Bit	10Bit
Dynamic:	62dB (1:1250)	60dB (1:1000)
Frame rate:	up to 40Hz (higher on request)	up to 20Hz (higher on request)
Exposure time:	100µs-100ms	100µs-100ms
Interface:	USB 3.0	USB 3.0
Shutter:	Global	Global
Mode:	cw or pulsed	cw or pulsed
Trigger:	TTL-Signal	TTL-Signal
<b>SPECIFICATIONS</b>		
Mechanical dimensions (W x H x L):	29mmx29mmx20mm	29mmx29mmx24mm
Weight:	26g	28g
Electrical requirements:	Power supply via USB	Power supply via USB
Storage temperature*:	-10°C...+60°C	-10°C...+60°C
Operating temperature*:	+0°C...+40°C	+0°C...+40°C
Regulations:	CE, RoHS	CE, RoHS

\* Without condensation

Design and specification of the described product(s) are subject to change without notice.

**CINOGY Technologies GmbH**  
Max-Näder-Str. 15 · 37115 Duderstadt · Germany  
Phone +49 5527 8483770 · Fax +49 5527 8483773  
e-mail info@cinogy.com · www.cinogy.com

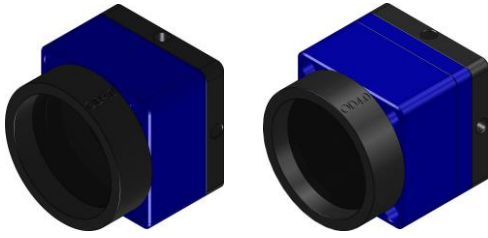

**CinCam CMOS Nano**  
**- Sensor Response -**  
**- Dimensions -**

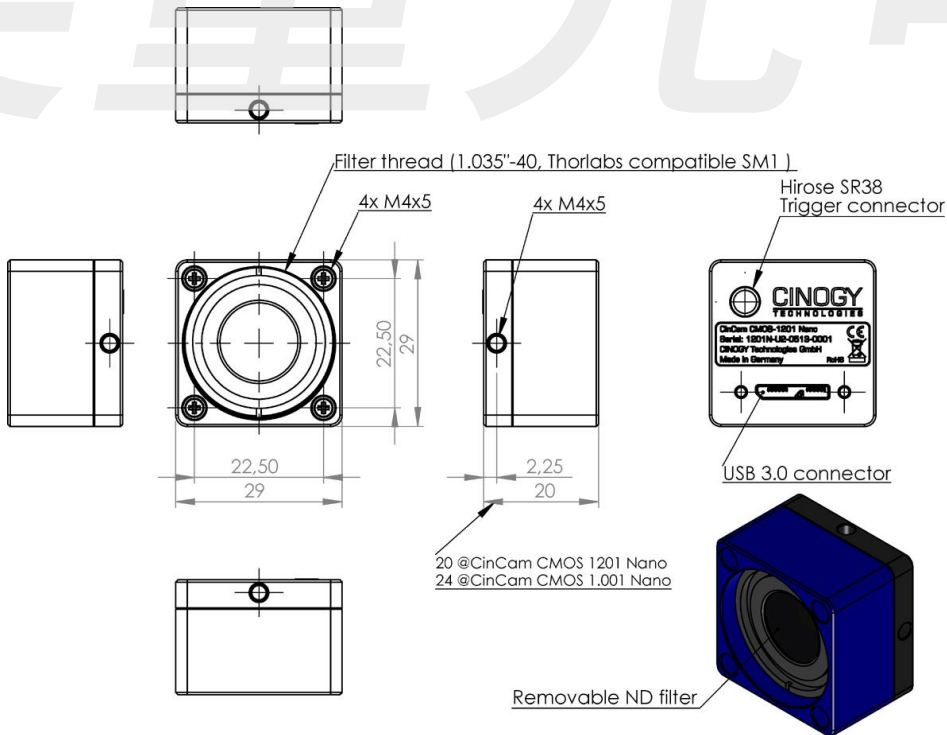
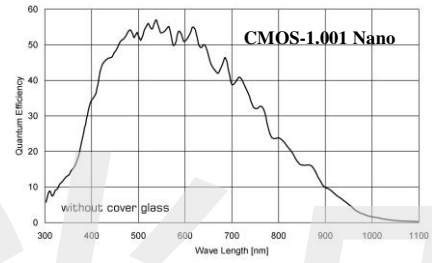
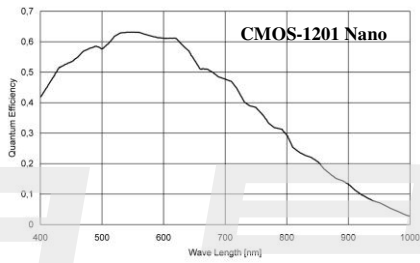

**CINOGY Technologies GmbH**  
Max-Näder-Str. 15 · 37115 Duderstadt · Germany  
Phone +49 5527 8483770 · Fax +49 5527 8483773  
e-mail info@cinogy.com · www.cinogy.com

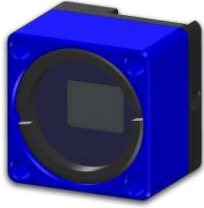

## CinCam CMOS Pico - Technical Data -

### CMOS-1201-Pico

#### Standard Series

SENSOR DATA	
Format:	1/2.5"
Active area (without cover glass):	5.7mm x 4.3mm
Number of pixel:	2560 x 1920 (5MPixel)
Pixel size:	2.2µm x 2.2µm
Spectral response:	
Standard: absorptive built-in ND filter	400nm - 1150nm
RT: reflective built-in ND filter	320nm - 1150nm
UV: phosphor sensor coating	<150nm - 1150nm
OM: sensor without microlenses	240nm - 1150nm
IR: phosphor sensor coating	1470nm - 1605nm
Beam diameter min / max (recommended):	22µm / 3.2mm
CAMERA FEATURES	
Mount:	Filter-Mount
Bit depth (output):	12Bit
Dynamic:	70dB (1:3150)
Frame rate:	up to 4.6Hz
Exposure time:	200µs-200ms
Interface:	USB 2.0
Shutter:	Rolling
Mode:	cw
Trigger:	-
SPECIFICATIONS	
Mechanical dimensions (W x H x L):	15mmx15mmx11.5mm
Weight:	20g
Electrical requirements:	Power supply via USB
Storage temperature*:	-10°C...+60°C
Operating temperature*:	+0°C...+40°C
Regulations:	CE, RoHS

\* Without condensation

Design and specification of the described product(s) are subject to change without notice.

**CINOGY Technologies GmbH**  
Max-Näder-Str. 15 · 37115 Duderstadt · Germany  
Phone +49 5527 8483770 · Fax +49 5527 8483773  
e-mail info@cinogy.com · www.cinogy.com

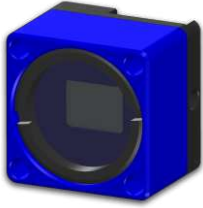

**CinCam CMOS Pico**  
**- Sensor Response -**  
**- Dimensions -**

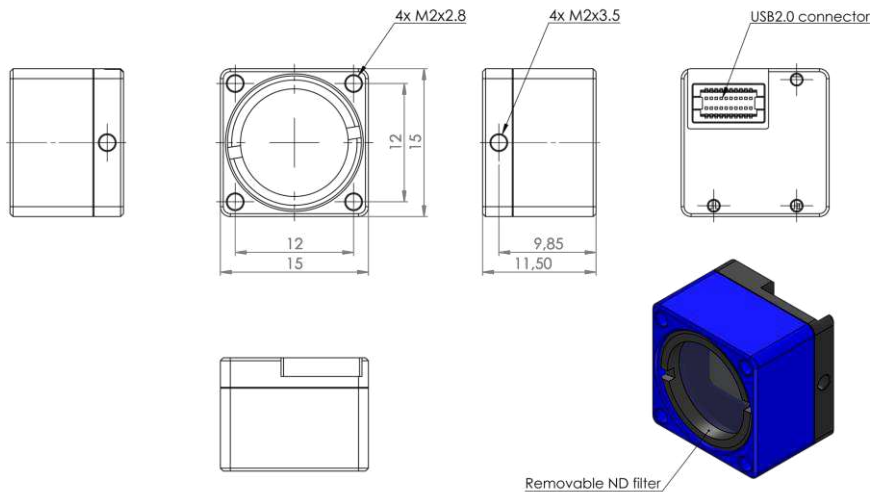
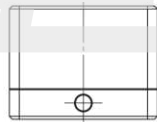
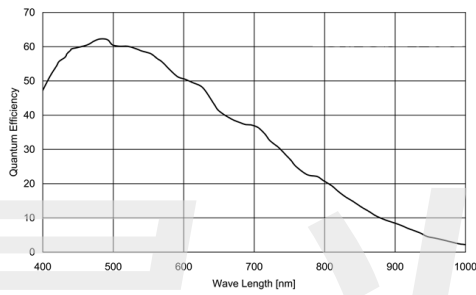

**CINOGY Technologies GmbH**  
Max-Näder-Str. 15 · 37115 Duderstadt · Germany  
Phone +49 5527 8483770 · Fax +49 5527 8483773  
e-mail info@cinogy.com · www.cinogy.com



## CinCam InGaAs - Technical Data -

	<b>CinCam-InGaAs-320</b>	<b>CinCam-InGaAs-640</b>
	<i>Standard Series</i>	<i>Standard Series</i>
<b>SENSOR DATA</b>		
Type:	InGaAs, progressive scan	InGaAs, progressive scan
Active area (without cover glass):	1", 9.6mm x 7.7mm	1", 9.6mm x 7.7mm
Number of pixel:	320 x 256	640 x 512
Pixel size:	30µm x 30µm	15µm x 15µm
Spectral response:	0.9µm - 1.8µm	0.9µm - 1.8µm
Beam diameter min / max (recommended):	300µm / 5.7mm	150µm / 5.7mm
Quantum efficiency:	>70% (1000nm-1640nm)	>75% (1000nm-1640nm)
Pixel operability:	>99.5%	>99.5%
Sensor cooling:	TEC (stabilized +5°C, -20K relative)	TEC (stabilized +5°C, -30K relative)
<b>CAMERA FEATURES</b>		
Mount:	Filter-Mount	Filter-Mount
Bit depth (output):	12Bit (A/D 14Bit)	12Bit (A/D 14Bit)
Frame rate:	up to 100Hz (300Hz)	up to 60Hz (100Hz)
Exposure time:	10µs-20ms	10µs-100ms
Dynamic range:	60dB (gain 1)	59dB (gain 0)
Interface:	GigE	GigE
Mode:	cw and pulsed	cw and pulsed
<b>SPECIFICATIONS</b>		
Mechanical dimensions (W x H x L):	55mmx55mmx78mm	55mmx55mmx78mm
Weight:	340g	370g
Electrical requirements:	10.8V to 30.0V or vie PoE	10.8V to 30.0V or vie PoE
Storage temperature*:	-30°C...+60°C	-30°C...+60°C
Operating temperature*:	-20°C...+50°C	-20°C...+50°C
Regulations:	CE, RoHS	CE, RoHS

\* Without condensation

Design and specification of the described product(s) are subject to change without notice.

**CINOGY Technologies GmbH**  
Max-Näder-Str. 15 · 37115 Duderstadt · Germany  
Phone +49 5527 8483770 · Fax +49 5527 8483773  
e-mail info@cinogy.com · www.cinogy.com





**CinCam InGaAs  
- Sensor Response -  
- Dimensions -**

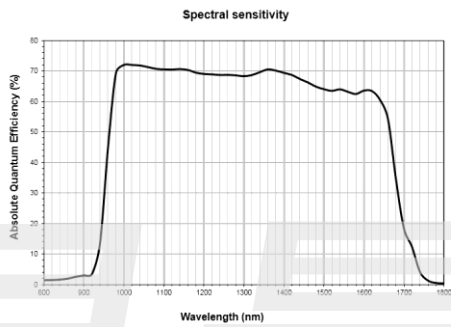

CinCam InGaAs-320

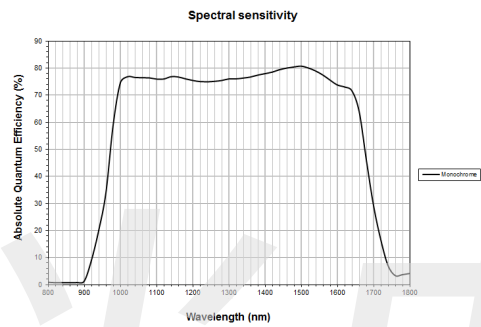

CinCam InGaAs-640

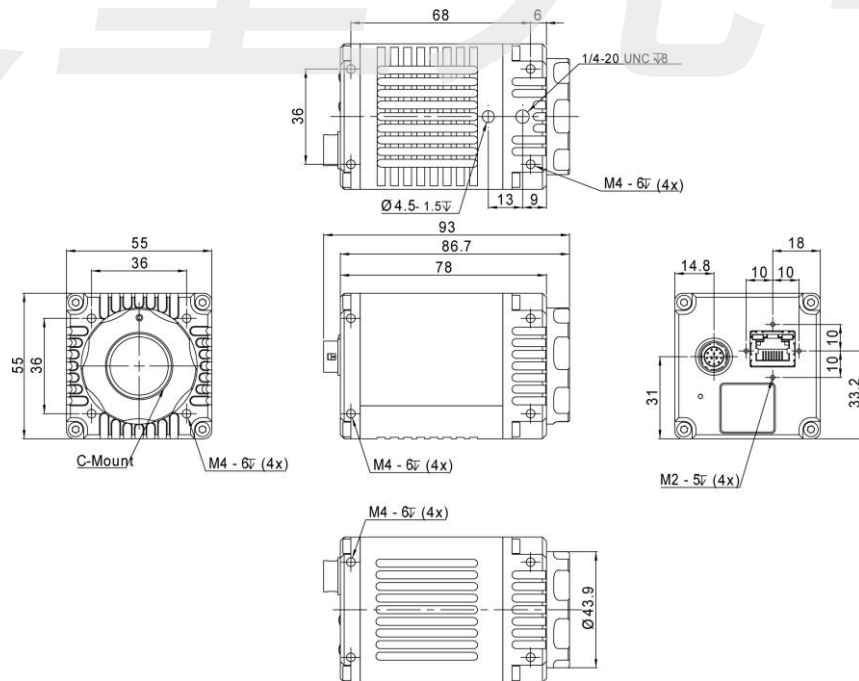

**CINOGY Technologies GmbH**  
Max-Näder-Str. 15 · 37115 Duderstadt · Germany  
Phone +49 5527 8483770 · Fax +49 5527 8483773  
e-mail info@cinogy.com · www.cinogy.com



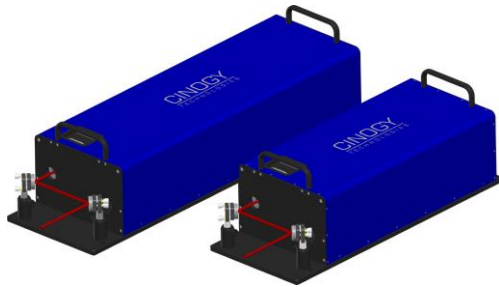

## CinCam Application Beam Quality $M^2$ - CinSquare -

The CinSquare CS200 / CS300 system is a compact and fully automated tool to measure the beam quality of cw and pulsed laser systems from the UV to NIR spectral range. This system consists of a fixed focusing lens in front of a motorized translation stage carrying a CinCam CCD/CMOS/InGaAs beam profiler. To analyse the beam caustic according to ISO 11146-1/2 the software calculates the beam size of several measurement planes via 2<sup>nd</sup> Moment method. The whole measuring process is fully automated and controlled by CINOGY's software RayCi.

The CinSquare measurement system is equipped with two alignment mirrors for exact positioning of the laser beam through the measurement set-up. An additional filter wheel allows incremental beam attenuation. Its operational robustness and reliability ensures continuous use applications in industry, science, research and development.

- Confirm to ISO 11146-1/2
- Robust and compact system in industrial design
- Up to 6 focusing lenses and 6 ND filters assembled
- Reliable and fully automated  $M^2$  measurement in <1 minute (~30s fast scan)
- Camera-based system
- 'CinCal' algorithm for high measurement accuracy
- 2D- and 3D-Caustic fit
- Compatible with cw and pulsed laser systems
- Measurement data as printable protocol (pdf)

Spectral response:	250nm-950nm@CCD / 350nm-1320nm@CMOS / 900nm-1700nm@InGaAs
Pixel size:	3.75 $\mu\text{m}^2$ @CCD / 5.3 $\mu\text{m}^2$ @CMOS / 15 $\mu\text{m}^2$ @InGaAs
Number of pixel:	1.3MPixel@CCD / CMOS / 0.3MPixel@InGaAs
Technology:	CCD / CMOS / InGaAs
Data output:	14Bit / 10Bit / 14Bit
Beam diameter ( $1/e^2$ ):	0.5-10mm
Stage length:	200mm (400mm)@CS-200 / 300mm@CS-300
ND filter:	up to 6 ND filters pre-assembled
Focusing lens:	up to 6 lenses pre-assembled
Input power:	up to 50W
Software:	RayCi-Pro
Dimensions CS200:	560 x 220 x 190mm <sup>3</sup>
Dimensions CS300:	745 x 220 x 190mm <sup>3</sup>

The software RayCi reports  $M^2$ , K, beam waist diameter, beam waist position, divergence angle, Rayleigh length, etc. Incomparable visualization modes, extensive analytical capabilities and new developed algorithms ensure the highest accuracy for beam quality measurements.

For scientific beam quality measurements CINOGY Technologies provides a pre-assembled and flexible measurement set-up in open design.

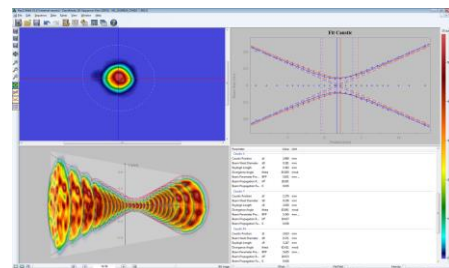
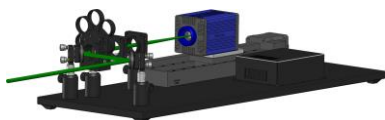

CINOGY's experienced team provides CinSquare systems tailored to customer's requirements.

**CINOGY Technologies GmbH**  
Max-Näder-Str. 15 · 37115 Duderstadt · Germany  
Phone +49 5527 8483770 · Fax +49 5527 8483773  
e-mail info@cinogy.com · www.cinogy.com

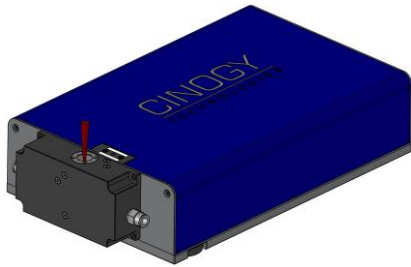

## CinCam Application Focus Beam Profiler - CinSpot FBP-50M-

The Focus-Beam-Profiler FBP-50M is a compact and fully automated tool to measure the focused laser beam from the UV to NIR range. The integrated CinCam beam profiler is moved precisely by the translation stage along the focus region. Its operational robustness and reliability ensures continuous use applications especially in industrial applications. A modular attenuation unit allows focus analysis up to 50W laser power. The whole measuring process is controlled by CINOGY's software RayCi.

<b>SENSOR DATA</b>	
Spectral response:	340nm-1150nm
Pixel size:	5.3 $\mu$ m <sup>2</sup>
Number of pixel:	1.3MPixel
Technology:	CMOS (CCD)
Data output:	10Bit
Interface:	USB 2.0 / GigE
<b>FEATURES</b>	
Objective:	4x (NA 0.1) / 10x (NA 0.25) / 20x (NA 0.4)
Focus spot size:	>16 $\mu$ m@4x / >6 $\mu$ m@10x / >3 $\mu$ m@20x (accept focal lengths >80mm)
Stage length:	100mm (accuracy 10 $\mu$ m / speed 10mm/s)
Input power (without attenuator):	max 100mW
Input power (with attenuator):	max 50W (water cooling / 2l/min, 1bar, 20-25°C)
Replaceable ND filter:	Absorptive type: OD1.0 / OD2.0 / OD3.0 / OD4.0 / OD5.0 (400nm - 1150nm)
Replaceable ND filter:	Reflective type: OD1.0 / OD2.0 / OD3.0 (340nm - 1150nm)
Accuracy:	Waist position 50 $\mu$ m / Spot size 2-4% (measurement position is calibrated)
Software:	RayCi-Pro
<b>SPECIFICATIONS</b>	
Mechanical dimensions (W x H x L):	334mm x 220mm x 84mm <sup>3</sup> (without attenuator) / 370mm x 220mm x 84mm <sup>3</sup> (with attenuator)
Weight:	~6kg
Electrical requirements:	36V
Water-cooling:	Water-cooled absorber, Tap or DI-water; 2l/min, 1bar, 20-25°C, Ø 8mm hose
Storage temperature:	-10°C...+60°C
Operating temperature:	+0°C...+40°C
Regulations:	CE, RoHS

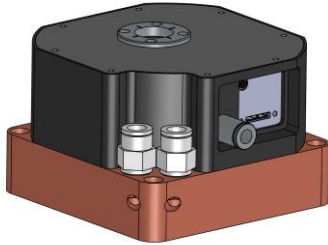

## CinCam Application Focus Beam Profiler - CinSpot FBP-1KF-

The Focus-Beam-Profiler FBP-1KF is a compact tool to measure the focused laser beam from the UV to NIR range for up to 400W laser input power. It works with a fixed measurement position and is characterized by very compact design. The operational robustness and reliability ensures continuous use applications especially in industrial applications. The whole measuring process is controlled by CINOGY's software RayCi.

SENSOR DATA		
Spectral response:	340nm-1150nm (1320nm)	340nm-950nm
Pixel size:	5.3 $\mu$ m <sup>2</sup>	3.45 $\mu$ m <sup>2</sup>
Number of pixel:	1.3MPixel	3.2MPixel
Technology:	CMOS	CMOS
Data output:	10Bit	12Bit
Interface:	USB 2.0 / USB 3.0	USB 2.0 / USB 3.0
FEATURES		
Collimated beam size:	0.5m-3mm	
Focus spot size:	$\geq 65\mu\text{m}@$ single mode / $\geq 300\mu\text{m}@$ multi mode	$\geq 42\mu\text{m}@$ single mode / $\geq 300\mu\text{m}@$ multi mode
Max NA / Divergence:	0.05 / 100mrad	
Input laser power:	max 400W@single mode / max 700W@multi mode	
	Measurement time with water-cooling @22°C: no limitation	
	Measurement time without water-cooling: 20s@400W	
Accuracy:	Waist position 50 $\mu$ m / Spot size 2-4% (measurement position is calibrated)	
Software:	RayCi-Pro	
SPECIFICATIONS		
Mechanical dimensions (W x H x L):	98mm x 98mm x 65mm	
Weight:	~2kg	
Electrical requirements:	Power supply via USB	
Water-cooling:	Water-cooled absorber, Tap or DI-water: 2l/min, 1bar, 20-25°C, Ø 8mm hose	
Dust protection:	Flushing with clean air to avoid contamination of the optics (cleaned, oil-free, dry, particles <10 nm)	
Storage temperature:	-10°C...+60°C	
Operating temperature:	+0°C...+40°C	
Regulations:	CE, RoHS	

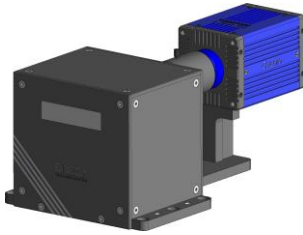

## CinCam Application Laser Line Characterization - CinLine -



The CinLine tool is a compact and unique tool to measure beam profiles of cw and pulsed laser systems from UV to NIR spectral range. This system includes a special designed diffusion screen and the camera-based CinCam CCD/CMOS beam profiler with imaging optic.

The sophisticated screen architecture enables speckle-free beam profiling especially of laser lines, rectangle profiles or laser with large beam diameter. Several versions are available to open up new opportunities in laser characterization. The compact measurement system is designed to be used in industry, science, research and development.

- Speckle-free diffusion screen
- Confirm to ISO standard
- Pre-assembled and compact measurement system
- Accurate and reliable measurements
- Compatible with cw and pulsed laser systems
- Measurement data as printable protocol

Spectral response:	320nm – 1150nm
Beam Profiler:	CinCam CMOS / CCD
Input Power (max):	500mW
Input Intensity (max):	10W/cm <sup>2</sup>
Resolution:	Up to 17μm
Interface:	FireWire / USB / GigE

The CinLine system is available with its specifically designed beam profiling software RayCi, which utilizes unique analytical capabilities and incomparable visualization modes. This ensures the highest accuracy in beam profile analysis.

- |             |   |  |
|-------------|---|--|
| I. Option   |  | Active Area: 30mm x 30mm<br>Beam Diameter (max): 20mm x 20mm |
| II. Option  |  | Active Area: 40mm x 20mm<br>Beam Diameter (max): 27mm x 13mm |
| III. Option |  | Active Area: 60mm x 15mm<br>Beam Diameter (max): 40mm x 10mm |

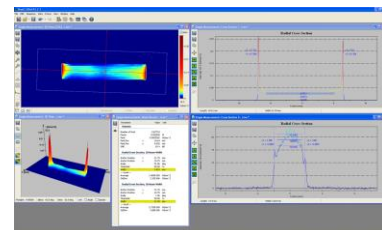

CINOGY's experienced team provides CinLine systems tailored to customer's requirements.



**CinCam Application  
Near-Field Beam Profiler  
- NFBP -**

CINOGY Technologies near field beam profiling option is suitable for focus spot measurements and near field imaging of fiber ends or output surfaces from laser diodes over a wide wavelength range. The set-up based on the compact CinCam CMOS models and can be assembled with different microscope objectives. These calibrated microscope objectives assured maximum accuracy and enables imaging of small beam structures on the diffraction limit.

	<b>4x System</b>	<b>10x System</b>	<b>20x System</b>	<b>40x System</b>
Magnification:	4x (calibrated)	10x (calibrated)	20x (calibrated)	40x (calibrated)
Numerical aperture (NA):	0.1	0.25	0.4	0.65
Working distance (WD):	15.8mm	10.0mm	3.3mm	0.6mm
Focal length:	29.8mm	15.26mm	8.55mm	4.39mm
Optical resolution:	~2µm	~1.5µm	~1.2µm	~1.0µm
Spectral range:				
Standard:	400nm - 1150nm	→ CMOS-1201 / 1202 / 1203 / 1204 // CMOS-1201-Nano / 1.001-Nano		
RT:	320nm - 1150nm	→ CMOS-1201 / 1202 / 1203 / 1204 // CMOS-1201-Nano / 1.001-Nano		
NIR: residual silicon response phosphor	400nm - 1320nm	→ CMOS-1202 / CMOS-1203 // CMOS-1201-Nano / 1.001-Nano		
IR: sensor coating	1470nm - 1605nm	→ CMOS-1201 / 1202 / 1203 / 1204 // CMOS-1201-Nano / 1.001-Nano		
Input power (max):	100mW@4x, 10x / 10mW@20x, 40x / Power level for 1320nm and 1550nm on request			
Replaceable ND filter:	Absorptive type: OD1.0 / OD2.0 / OD3.0 / OD4.0 / OD5.0 (400nm - 1320nm, 1470nm -1605nm) Reflective type: OD1.0 / OD2.0 / OD3.0 (320nm - 1320nm)			
Beam profiler resolution:				
CinCam CMOS-1201	1280 x 1024 pixel	→ 5.2µm x 5.2µm		
CinCam CMOS-1202	1280 x 1024 pixel	→ 5.3µm x 5.3µm		
CinCam CMOS-1203	1600 x 1200 pixel	→ 4.5µm x 4.5µm		
CinCam CMOS-1204	2560 x 1920 pixel	→ 2.2µm x 2.2µm		
CinCam CMOS-1201-Nano	1280 x 1024 pixel	→ 5.3µm x 5.3µm		
CinCam CMOS-1.001-Nano	2040 x 2040 pixel	→ 5.5µm x 5.5µm		
Field of view:				
CinCam CMOS-1201	1664µm x 1331µm	666µm x 533µm	333µm x 267µm	167µm x 134µm
CinCam CMOS-1202	1696µm x 1357µm	678µm x 543µm	339µm x 272µm	170µm x 136µm
CinCam CMOS-1203	1800µm x 1350µm	720µm x 540µm	360µm x 270µm	180µm x 135µm
CinCam CMOS-1204	1408µm x 1056µm	563µm x 422µm	282µm x 211µm	141µm x 106µm
CinCam CMOS-1201-Nano	1696µm x 1357µm	678µm x 543µm	339µm x 272µm	170µm x 136µm
CinCam CMOS-1.001-Nano	2825µm x 2825µm	1130µm x 1130µm	565µm x 565µm	283µm x 283µm
Beam size:				
CinCam CMOS-1201	~13µm - 666µm	~5.2µm - 267µm	~2.6µm - 134µm	~1.3µm - 67µm
CinCam CMOS-1202	~14µm - 678µm	~5.3µm - 272µm	~2.6µm - 136µm	~1.3µm - 68µm
CinCam CMOS-1203	~11µm - 675µm	~4.5µm - 270µm	~2.3µm - 135µm	~1.1µm - 67µm
CinCam CMOS-1204	~5.5µm - 528µm	~2.2µm - 211µm	~1.1µm - 106µm	~0.6µm - 53µm
CinCam CMOS-1201-Nano	~14µm - 678µm	~5.3µm - 272µm	~2.6µm - 136µm	~1.3µm - 68µm
CinCam CMOS-1.001-Nano	~13µm - 1875µm	~5.5µm - 750µm	~2.8µm - 375µm	~1.4µm - 188µm

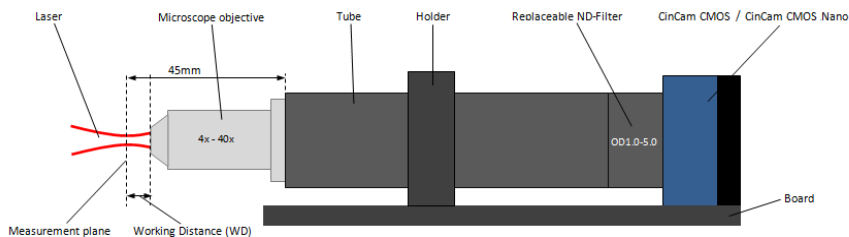

**CINOGY Technologies GmbH**  
Max-Näder-Str. 15 · 37115 Duderstadt · Germany  
Phone +49 5527 8483770 · Fax +49 5527 8483773  
e-mail info@cinogy.com · www.cinogy.com





## Neutral Density Filter - Technical Data -

CINOGY's neutral density filters allow broadband attenuation for a spectral range from VIS to NIR. Due to their excellent surface quality the absorptive and reflective filters enable precise beam attenuation for low power applications. The level of attenuation is specified by the optical density. Filters with different optical densities can be combined. A filter adapter is available to mount the filters on the CinCam aperture.

	<b>Reflective</b>	<b>Absorptive</b>	<b>Absorptive AR</b>
	<b>NDR-0.3 - NDR-30</b>	<b>NDA-0.3 - NDA-50</b>	<b>NDA-0.3 - NDA-50</b>
Spectral range:	200nm - 2100nm	400nm - 1700nm	400nm - 700nm/700nm - 1200nm
Optical density*:	0.3 / 1.0 / 2.0 / 3.0	0.3 / 1.0 / 2.0 / 3.0 / 4.0 / 5.0	0.3 / 1.0 / 2.0 / 3.0 / 4.0 / 5.0
Material:	UV-Fused silica (Coating: Metal)	Schott glass	Schott glass (AR Coating)
Flatness:	1λ @ 300nm	λ/4 @ 632.8nm	λ/4 @ 632.8nm
Scratch-Dig:	40 - 20	40 - 20	40 - 20
Parallelism:	3arcmin	10arcsec	10arcsec
Optical density tolerance:	±5%	±5%	±5%
Power (P <sub>max</sub> ):	< 1W	< 1W	< 1W
Intensity (I <sub>max</sub> ):	10W/cm <sup>2</sup>	5W/cm <sup>2</sup>	5W/cm <sup>2</sup>
Diameter:	Ø=25mm/25.4mm / Ø=50mm/50.8mm	Ø=25mm/25.4mm / Ø=50mm/50.8mm	Ø=25mm/25.4mm / Ø=50mm/50.8mm
Filter adapter:	C-Mount thread / Filter thread	C-Mount thread / Filter thread	C-Mount thread / Filter thread

\* Different optical densities on request

Design and specification of the described product(s) are subject to change without notice.

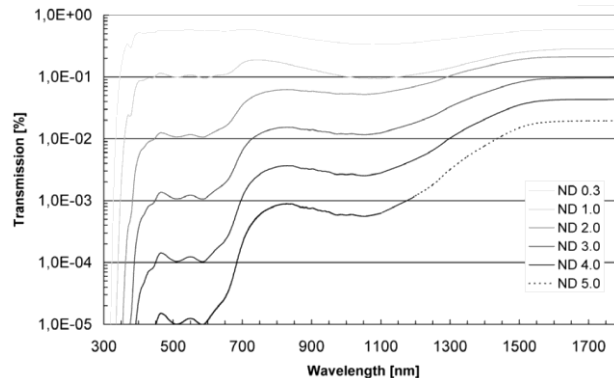



## Beam Reducer Objective - Technical Data -

The beam reducer is an add-on to the standard CinCam Beam Profiler. It is designed for adjusting the laser beam size precisely to the effective area of the Beam Profiler. Thereby, the reduction factor and the measurement plane are calibrated. The beam reducer offers high performance optical designs packaged in a precise opto-mechanical platform. The input aperture allows beam profiling of lasers with diameters up to 12mm with CINOGY's CinCam systems.

	<b>BR-UV/VIS-01</b>	<b>BR-VIS/NIR-01</b>	<b>BR-NIR-01</b>
Spectral range:	350 - 700nm	650 - 1080nm	1040 - 1650nm
Ratio:	2x; 3x; 4x	2x; 3x; 4x	2x; 3x; 4x
Free aperture:	22mm	22mm	22mm
Beam diameter (1/e <sup>2</sup> ):	max 12mm	max 12mm	max 12mm
Damage threshold:	0.4J/cm <sup>2</sup> (@ 10ns, 532nm) 300W/cm <sup>2</sup>	2J/cm <sup>2</sup> (@ 10ns, 810nm) 500W/cm <sup>2</sup>	2J/cm <sup>2</sup> (@ 10ns, 1550nm) 300W/cm <sup>2</sup>
Calibration:	Reduction Factor Measurement Plane	Reduction Factor Measurement Plane	Reduction Factor Measurement Plane
Lens:	Achromatic Lens	Achromatic Lens	Achromatic Lens

Design and specification of the described product(s) are subject to change without notice.

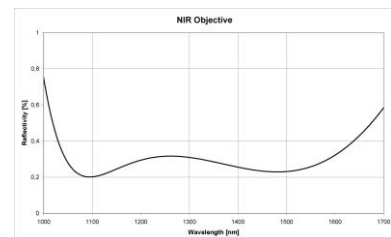
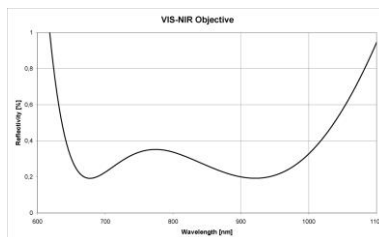
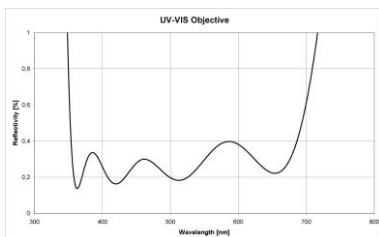





## IR Module - Technical Data -

The C-Mount converter module is an add-on to a standard CinCam Beam Profiler and extends sensitivity into the near IR range. The cost effective module is based on complex and non charge anti-stokes material with unique emission properties and converts 1495nm-1595nm photons to CCD / CMOS detectable wavelengths without fading or image lag. A lens transfers the converted image to the attached CinCam Beam Profiler.

<b>MO-IR-01</b>	
Sensitivity:	1470nm-1605nm
Active area:	22mm x 16.5mm (demagnification x0.29)
Material:	Phosphor (anti-stokes)
Decay time:	<1ms
Emission spectrum:	950nm-1075nm
Resolution:	40lp/mm at sensor focal plane
Linearity:	Non-linear (corrected by software)
Dynamic range:	42dB (CinCam CCD-1201) / 43dB (CinCam CMOS-1201) / 44dB (CinCam CMOS-1202)
Max input intensity:	1W/cm <sup>2</sup>
Beam diameter accuracy:	5%-10%
Camera mount:	C-Mount
Dimensions (O.D. x L):	46mm x 97mm

Design and specification of the described product(s) are subject to change without notice.

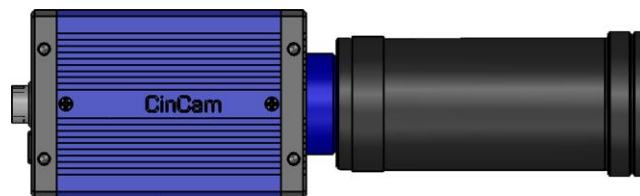

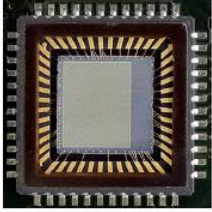

## IR Sensor Coating - Technical Data -

The complex and non charge anti-stokes phosphor is also suitable as direct sensor coating. The coating can be used with CinCam CCD/CMOS models. This solution finds application as sensitive detector for beam profiling or alignment of telecom lasers. The real time nature confers significant and cost effective benefits over other IR imaging techniques.

Phosphor type:	1470nm-1605nm (Anti stokes - rare earth dopant)
Particle size range:	5 $\mu$ m - 9 $\mu$ m
Absorption characteristics:	3 band - 0.8 $\mu$ m, 1.0 $\mu$ m, 1.55 $\mu$ m
Decay to 10%:	<1ms
Sensitivity:	1470nm - 1605nm
Peak sensitivity:	1510 / 1540 (multi peak response)
Emission spectrum:	950nm - 1075nm
Afterglow:	Low
Linearity:	Non-linear (corrected by software)
Dynamic range:	42dB (CinCam CCD-1201) / 43dB (CinCam CMOS-1201) / 44dB (CinCam CMOS-1202)
Damage threshold:	100 mW/cm <sup>2</sup>
Beam diameter accuracy:	5% - 10%
Robustness:	moderate

Design and specification of the described product(s) are subject to change without notice.

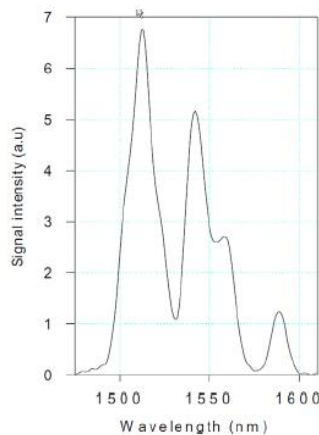

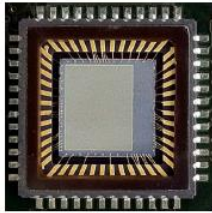

## UV Sensor Coating - Technical Data -

A typical limitation of CCD / CMOS sensors is that light with short wavelengths is absorbed by the very first structures of the sensor and is not recognized as a signal. The shorter the wavelength is, the less the sensors output signal is affected by illumination. A UV to VIS converting coatings which absorbs UV light and emits visual light instead is covered by a thin layer on the sensor. The robust fluorescent material is ideally suited for UV imaging. The material shows an excellent quantum yield of nearly 100% for wavelengths below 450nm and down to 100nm. In contrast there is a high transparency of the material for wavelengths above 480nm which gives a very good response even in the visual and near infrared range.

Technology:	Fluorescence material (Lumigen)
Thickness:	1µm
Sensitivity:	<150nm - 450nm
Emission spectrum:	500nm - 650nm
Peak emission:	530nm
Fluoresces decay time:	Some ns
Phosphorescence:	Not significant
Resolution:	Sensor MTF is reduced by 50%
Technology:	Fluorescence material (Lumigen)

Design and specification of the described product(s) are subject to change without notice.

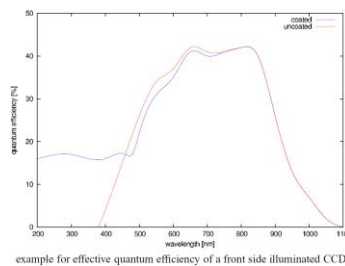
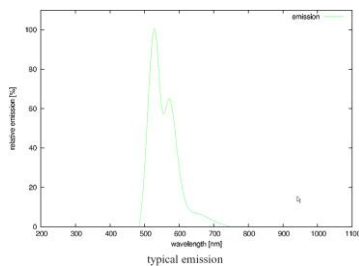

All UV coatings show aging effects (degradation). But CINOGY Technologies gives important handling advice to significantly extend the lifetime (e.g. low illumination, no overexposed).

### Sensor without Microlenses (On Request):

Alternatively, CINOGY Technologies has developed a unique technique to remove the microlenses on the sensor resulting in higher sensitivity down to 240nm.

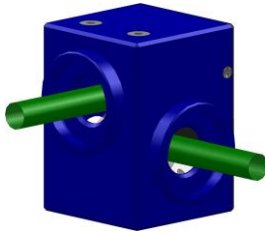

## Prism Attenuator - Technical Data -

The modular prism attenuator is an add-on to the standard CinCam Beam Profiler. It is based on two uncoated fused silica wedges and is designed for pre-attenuation high intensive laser beams. The technical principle is based on the polarization effect by reflection on an optical surface. The s-pol. and p-pol. parts of the laser beam have different reflection factors. Cause of the orthogonally arrangement of the wedges, the polarization effect is compensated and the laser beam is neutrally attenuated.

The prism attenuator can be used up to intensities of 2GW/cm<sup>2</sup> for pulse wave and 25kW/cm<sup>2</sup> for continuous wave. It can be combined with neutral density filters for final power adjustment to the beam profiler sensitivity level. The high performance optical design in compact housing allows precise beam attenuation.

	<b>PA-12-2x-100</b>	<b>PA-12-2x-200</b>
Spectral range:	190nm - 2.000nm	190nm - 2.000nm
Wedge material:	Uncoated fused silica	Uncoated fused silica
Free aperture:	Ø=15mm	Ø=15mm
Power (P <sub>max</sub> ):	<100W	<200W
Intensity (I <sub>max</sub> ) cw:	<20kW/cm <sup>2</sup>	<20kW/cm <sup>2</sup>
Intensity (I <sub>max</sub> ) pulsed:	2GW/cm <sup>2</sup> / 30J/cm <sup>2</sup> @ 15ns, 1Hz	2GW/cm <sup>2</sup> / 30J/cm <sup>2</sup> @ 15ns, 1Hz
Dimensions:	40mmx40mmx80mm	40mmx40mmx80mm

Design and specification of the described product(s) are subject to change without notice.

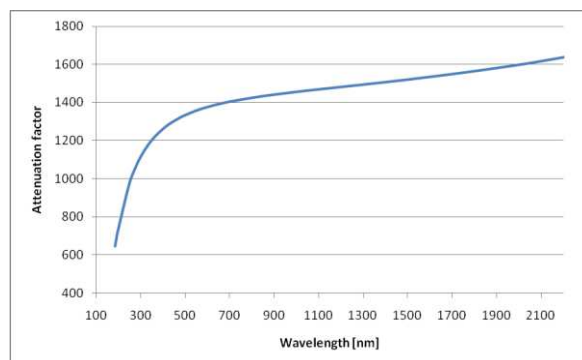

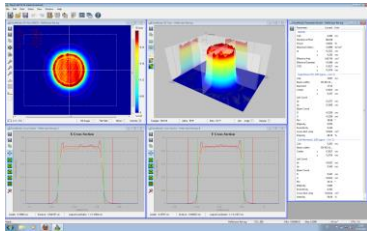

## Beam Profiler Software RayCi - Product Description -

CINOGY Technologies beam profilers are available with the specifically designed analysis software, RayCi, which supports XP / Vista / Windows 7 / 8 operating systems. It is available as 32 Bit / 64 Bit version and can control several beam profiler cameras on a single computer simultaneously.

ISO 11145  
ISO 11146  
ISO 11670  
ISO 11554  
ISO 13694

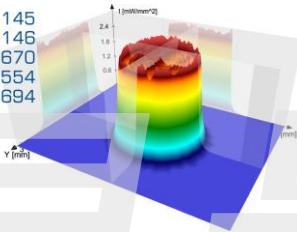

XP / Vista / Windows 7 / 8
Pentium IV / AMD Processor (Dual / Quad Core)
512MB graphic, Open GL V1.4 (NVIDIA)
2GB RAM
500MB free memory
PCI / PCIe slot
USB ports
CD / DVD-ROM drive
Internet access for update request

Due to its clearly designed menu structure, RayCi shows self-explanatory functions, which help the user to access quickly standard settings. Incomparable visualization modes, extensive analytical capabilities as well as new developed correction algorithms ensure the highest accuracy in laser beam analysis.

A wide range of beam width techniques e.g. 2<sup>nd</sup> Moment, Knife Edge, Moving Slit, Plateau and Gauss-Fit can be applied to determine quick and reliable standard beam parameters. The unique measurement tool enables the continuous monitoring of beam parameters, beam position and power density distribution. Moreover a new beam quality M<sup>2</sup> tool enables accurate beam quality analysis.

The extraordinary graphical and analytical tool of RayCi can be used for live data (LiveMode) and stored data (SaveMode) simultaneously, while each mode has its own individual functions. This makes RayCi the most advanced analysis software on the market. Helpful features like AOI Tracking, AOI Optimization, Zoom Functions, Look-Up Tables, etc. simplify the laser beam analysis.

RayCi is equipped with flexible data and image output capabilities. This permits the user to store data and images in the format that is compatible with their needs. A clearly arranged and printable protocol view displays the measurement parameters as well as the most important laser beam analysis results.

CINOGY'S laser beam profiler can easily be integrated in different automation systems and processes. The supplied Software Development Kit (SDK) based on a XML-rpc interface. The user can write programs in a number of platforms, such as Python, Visual Basic, LabVIEW, etc. which will remote-control the beam profiler.

