

FEATURES

- Direct Time Measurement of Pulse Trains
- Measure Jitter, Frequency, Time Interval (Skew), Pulse Width, Risettime, Event Timing, Time Interval Error (TIE), and More
- 8 ps Single-Shot Resolution (12 Digits/s Frequency)
- DC to 400 MHz Frequency Range for all Measurement Functions Including Pulsewidth, Plus an optional Prescaler for Frequency and TIE Measurements to 2.5 GHz (BI220) or 5.0 GHz (BI221)
- Up to 1 Million Continuous Zero Dead Time Measurements Per Second
- 1 ns Minimum Pulse Width
- Highly Sophisticated and Flexible Arming (Triggering)
- PCI (BI220) or PXI (BI221) Interface
- On-board Memory for 8 Million Measurements – Can Be Read While Measurements are Taking Place

More Tests in Less Time

The BI220/BI221 are high performance time and frequency measurement instruments. Their high resolution and throughput, combined with continuous measurement capability, allow you to make measurements that are not possible with traditional time-interval counters. For example, they can timetag events (edges of an input pulse train) at a rate of 1 million per second continuously to on-board memory, while each of the edges is measured with 8 ps resolution. This provides them with the capability to analyze the dynamic variations in pulse timing, pulsewidth, or frequency. In other words, the difference between time interval analyzers and traditional counter/timers is analogous to the difference between voltmeters and scopes. Measurements can also be streamed continuously over the PCI interface allowing unlimited acquisition at high rates.

Full-Featured Instruments

The BI220/BI221 are full instruments-on-a-card with all the features and capabilities you would expect in bench-top instruments including high quality inputs, built-in NIST traceable calibration, and software and hardware that deliver fully computed results. The instruments have 10 measurement functions such as Frequency, Time Interval and Pulsewidth. All functions work directly on the input signal at frequencies up to 400 MHz without any prescaling. This means that you can measure pulses as narrow as 1 ns, occurring at frequencies up to 400 MHz, or the skew between two signals at 400 MHz. There is also an optional prescaler for each input channel which allows frequency and period measurements to 2.5 GHz (BI220) or 5.0 GHz (BI221).

The inputs of the instruments include programmable termination voltages. This feature is seldom found even in the best of the bench-top instruments. You can select by software control either a 1M Ohm impedance to ground, or a 50 ohm load which is terminated to an accurately programmable voltage between -3 V and +3 V. This allows you to connect ECL, PECL, or CML sources directly to the instruments with the proper loading.

APPLICATIONS

- PLLs and frequency modulation – measure jitter, time interval error and settling time
- Ultrasonic and radar pulse timing
- Optical and magnetic disk drive – measure jitter, risetime, and bit timing directly
- Oscillators and crystals – measure frequency, start-up time and time interval error
- Pulse width modulated signals – measure variations over time
- Time stamping of events in real time
- Nuclear physics

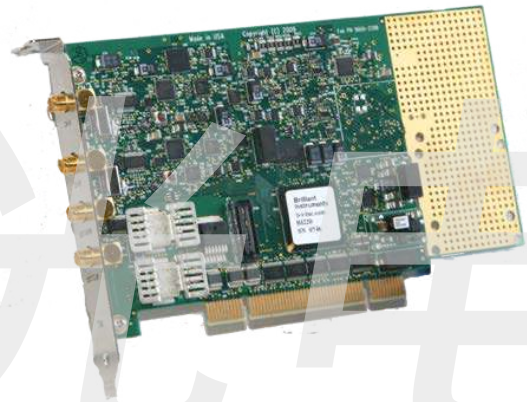

BI220



BI221

Easy to Use Software

The software for the BI220/BI221 is designed for ease of use and extremely high performance. The driver software (Windows and Linux) automatically manages the streaming of measurements at the high rates which are possible with the PCI interface. The front panel software for Windows allows you to easily set up multiple simultaneous displays of the measurements. This gives multiple views of the same data, or different functions from the same data. For example, you can set up

the display to show a graph of the frequency of the signal vs. time, plus a tabular display of the same results, plus a graph of the time deviation of the signal vs. time, all from the same measurement acquisition run. The front panel can also run multiple instruments simultaneously. All instrument models use the same driver for easy migration between models.

The screen image below is from an actual measurement of a 400 MHz clock. One thousand single channel measurements were taken. The tabular display shows 1000 frequency meas-

urements and the times and event numbers when they were taken. The digital display shows the statistics on period calculations of the same data. The graph display shows the TIE (Time Interval Error) calculations vs. time. Note that all 1000 measurements were taken in less than 1 ms and the resolution of the instrument is clearly evident with the Y axis of the graph at 5 ps per division.

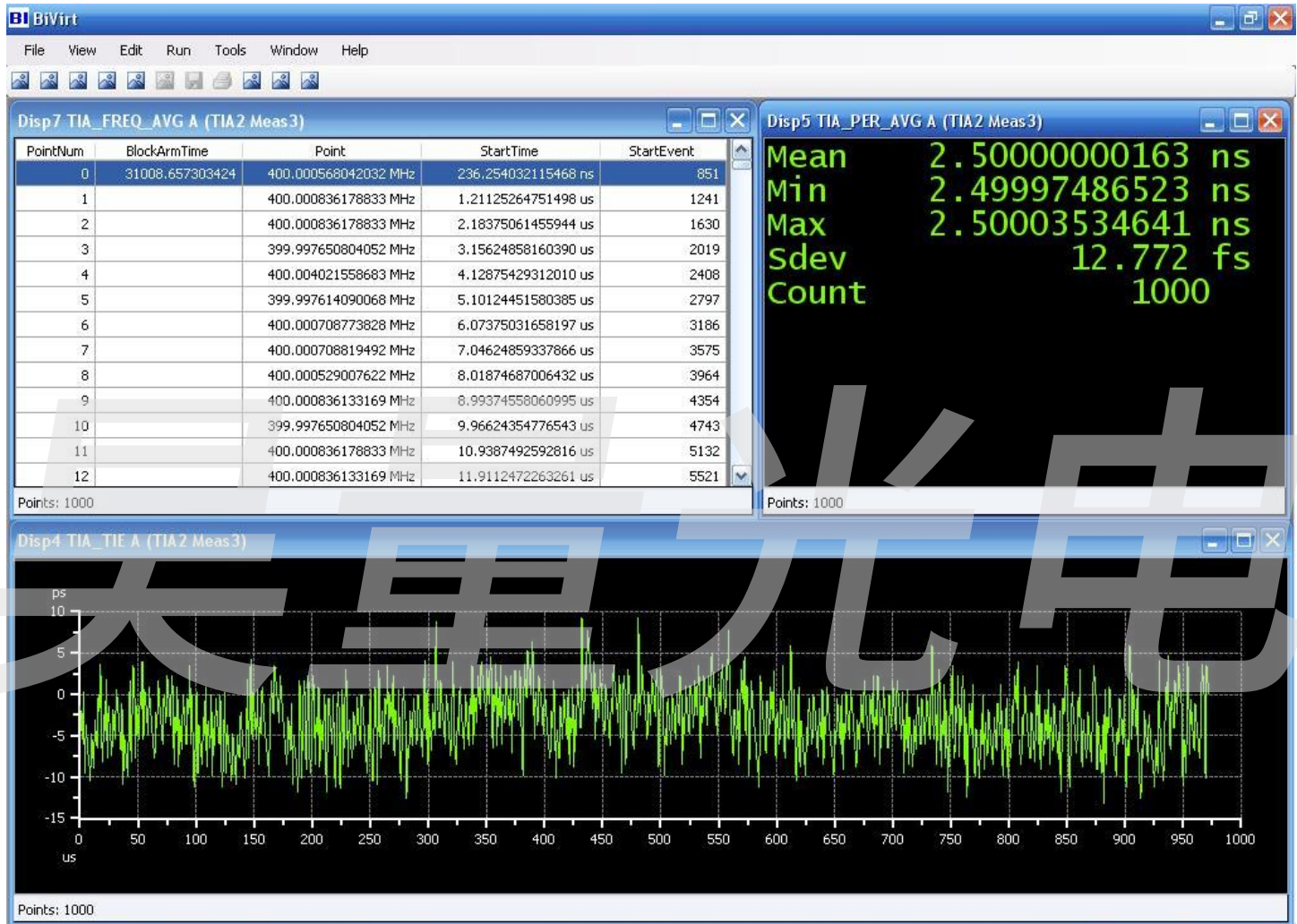

HOW DOES IT WORK?

The simplified block diagram below shows the key components of the instrument from the user's point of view. The input signal is terminated by 1M ohm to ground or 50 ohms to a user-programmable voltage (V_t) and fed to a comparator. The comparator output goes high when the signal crosses a user-programmable threshold voltage (V_{th}). At this point the signal is a digital waveform whose rising or falling edges are considered to be "events". These events are continuously counted by the Event Counter, while the Arming System selects the edges which are to be timetagged according to the user configuration. For example, you can set up the instrument to timetag every N events, or every T seconds.

When an event is timetagged, the event count (pulse number) and the time of the occurrence are logged to memory. The Timetag Circuits require a recovery time of 1 μ s to be ready for another timetag. Note, however, that the signal is still counted by the Event Counter, so no information is lost. This recovery time means that up to 1 million timetags (or pairs of timetags) can be logged per second. From this timetag data the instrument calculates the measurement results.

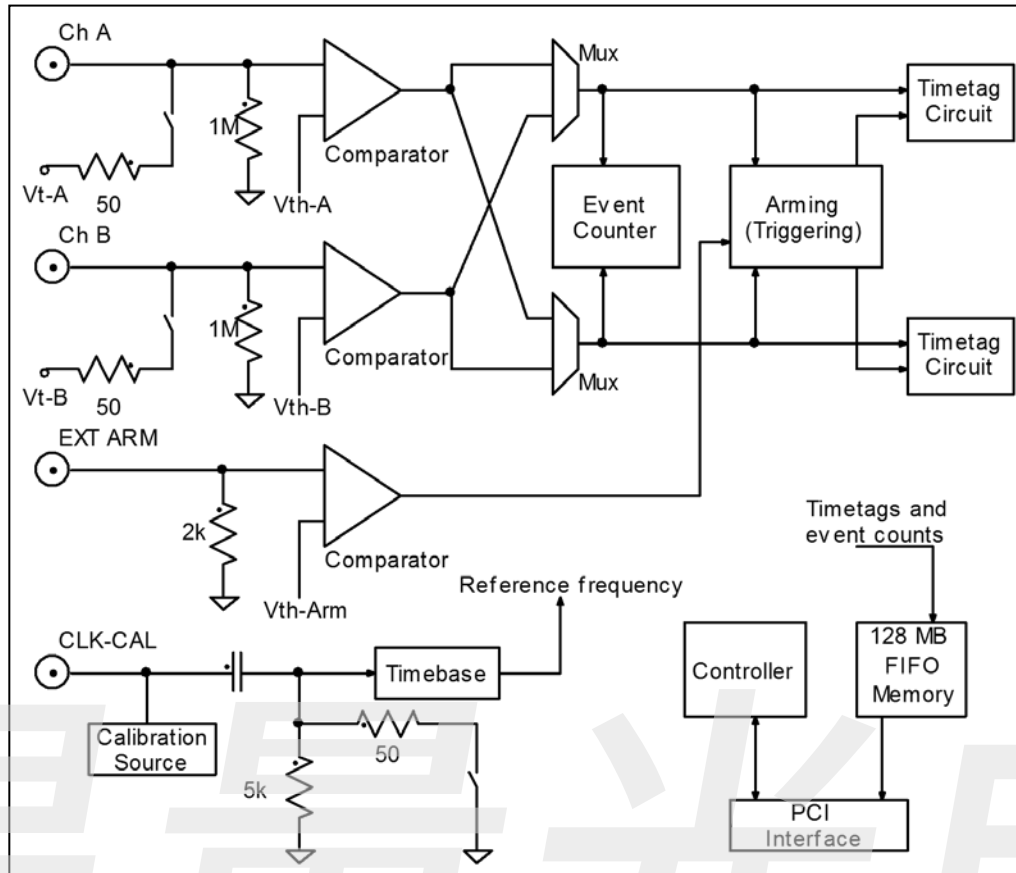

Figure 1: Simplified block diagram

There are three groups of measurement functions – 1C1E, 1C2E, and 2C2E. The timing diagrams below illustrate the operation of the instrument for each group.

One-Channel-One-Edge Functions

The 1C1E functions (one-channel-one-edge) operate on a single channel (either A or B) and use only one timetagging circuit. That is, each timetag contains only one edge time and one event count. The recovery time of 1 μs is the minimum time between timetags. That is, for frequencies below 1MHz it is possible to measure every rising or falling edge. The equations for the first measurement point in the timing diagram are shown in the table below. For example, in the equation for Frequency Average E1 and E2 are event counts while T1 and T2 are the time information from the first two timetags. Note that you can make up to 1 million frequency measurements per second on a continuous zero-dead-time basis. The measurement points are back to back since the end of one point is the start of the next one.

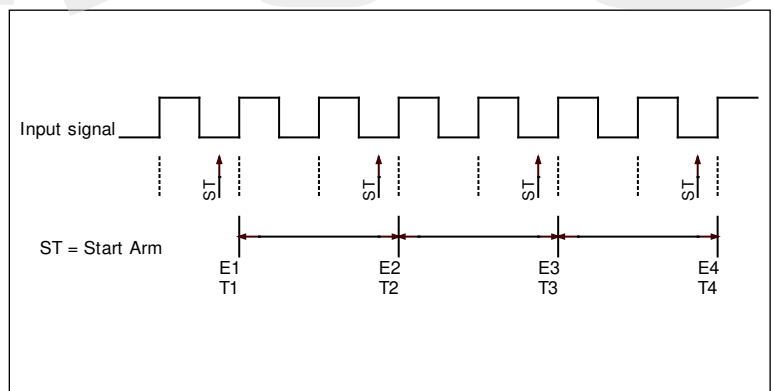

Figure 2: 1C1E functions

Function	Calculation	Notes
Frequency Average	$FreqAvg = \frac{\Delta E}{\Delta T} = \frac{E2 - E1}{T2 - T1}$	Average frequency of the input signal
Period Average	$PeriodAvg = \frac{\Delta T}{\Delta E} = \frac{T2 - T1}{E2 - E1}$	Average period of the input signal
Continuous Time Interval	$CTI = \Delta T = T2 - T1$	The actual time between pairs of timetags
Time Interval Error	$TIE = T1 - ExpectedTime$	The deviation in time of each of the timetags from an expected value. The user supplies the reference period of the signal

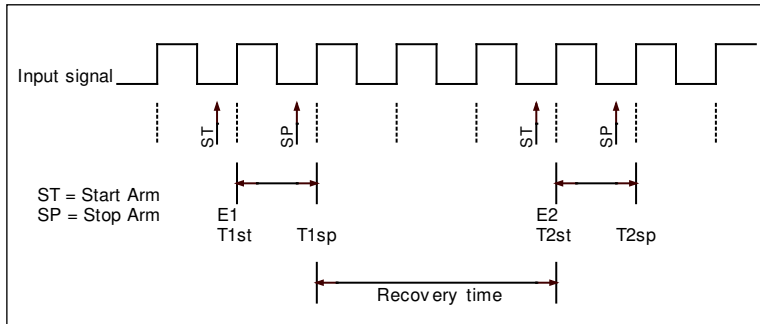

Figure 3: 1C2E functions

One-Channel-Two-Edge Functions

The 1C2E functions (one-channel-two-edge) operate on a single channel (either A or B) and use both timetagging circuits. That is, each timetag contains two edge times and one event count. The recovery time of 1 μ s is the minimum time between the stop timetag and the next start timetag. For all these functions the result is the difference in time from the start to the stop. The associated event count is for the start event. The arming that the user specifies is for the Start Arm, while the Stop Arm is dictated by the function.

Function	Stop Arm	Notes
Period	Next same edge	Measures single periods of the input signal
Pulsewidth	Next opposite edge	Measures individual pulsedurations of the input signal
One-Channel Time Interval	Next signal edge	The polarity of the start and stop edges is specified by the user
Risetime, Falltime	Same signal edge	Measures a single edge with two thresholds, usually 20% and 80%

Two-Channel-Two-Edge Functions

The 2C2E functions (two-channel-two-edge) operate on both channels (A to B or B to A) and use both timetagging circuits. That is, each timetag contains two edge times and one event count. The recovery time of 1 μ s is the minimum time between the stop timetag and the next start timetag. For the 2-Ch Time Interval function the result is the difference in time from the start to the stop. The associated event count is for the start event. The user can specify the polarity of the start edge and the stop edge and a delay for the Stop Arm. The delay provides for the selection of the stop edge. For example, when the Stop Arm Delay is set to 0, the instrument will measure down to a 0 time interval (zero skew between channel A and B).

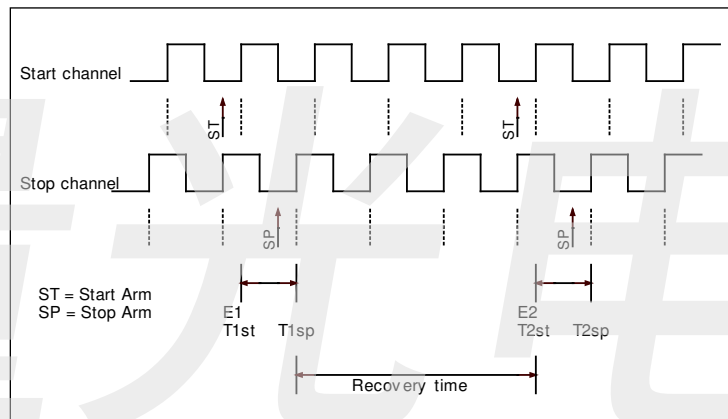

Figure 4: 2C2E functions

SPECIFICATIONS

General

- See "Definitions" below for explanation of the terms in the specifications
- Warranty: 1 year

Measurement Functions

- Fully symmetrical operation – all functions are the same for channel A or B
- One-Channel One-Edge (1C1E) Functions:
 - Frequency Average
 - Period Average
 - Continuous Time Interval (CTI)
 - Time Interval Error (TIE)
- One-Channel Two-Edge (1C2E) Functions:
 - Period (Per)
 - Pulsewidth (PW)
 - 1-Ch Time Interval (TI1)
 - Risetime

- Falltime
- Two-Channel Two-Edge (2C2E) Functions:
 - 2-Ch Time Interval (TI2)
- In addition to the measurement results, all functions provide the actual timetag in absolute time and the event count for each measurement (using the Table display)

Frequency Average A or B

- Measures the average frequency between pairs of events on a zero-dead-time basis (measurements are back to back)
- Type: 1C1E (One-Channel One-Edge)
- Frequency range (direct): DC to 400 MHz
- Frequency range (with optional prescaler):
 - BI220: 50 MHz to 2.5 GHz
 - BI221: 100 MHz to 5.0 GHz
- Measurement time ("gate time"): 1 μ s to 10 years
- Number of events per measurement: 1 to 1×10^{18}
- Number of significant digits: 12 digits/s (9 digits in 1 ms, or 5 digits in 1 μ s) regardless of input frequency

- Resolution (in Hz rms):

$$\pm \frac{Freq \times (8ps(rms) + 1.4 \times TriggerErr)}{Meastime}$$

- Accuracy (in Hz): $\pm Resolution \pm TimebaseErr$

Period Average A or B

- Measures the average period between pairs of events on a zero-dead-time basis (measurements are back to back)
- Type: 1C1E (One-Channel One-Edge)
- Range (direct): 2.5 ns to 10 years
- Range (with optional prescaler):
 - BI220: 400 ps to 20 ns
 - BI221: 200 ps to 10 ns
- See Frequency Average function for measurement time, number of events, and significant digits
- Resolution (in seconds rms):

$$\pm \frac{Period \times (8ps(rms) + 1.4 \times TriggerErr)}{Meastime}$$

- Accuracy (in seconds): $\pm Resolution \pm TimebaseErr$

Continuous Time Interval (CTI) A or B

- Measures the time between pairs of events on a zero-dead-time basis (measurements are back to back)
- Type: 1C1E (One-Channel One-Edge)
- Frequency range (direct): DC to 400 MHz
- Frequency range (with optional prescaler):
 - BI220: 50 MHz to 2.5 GHz
 - BI221: 100 MHz to 5.0 GHz
- Range: 1 μ s to 10 years
- Measurement time: 1 μ s to 10 years (can comprise multiple periods of the input signal)
- Number of events per measurement point: 1 to 1×10^{18}
- Resolution:
 $\pm 8 ps(rms) \pm 1.4 \times TriggerErr$
- Accuracy: $\pm Resolution \pm TimebaseErr \pm 50 ps$

Time Interval Error (TIE) A or B

- Measures the time of occurrence of events, then calculates the deviation from the expected period of the signal
- Type: 1C1E (One-Channel One-Edge)
- Frequency range (direct): DC to 400 MHz
- Frequency range (with optional prescaler):
 - BI220: 50 MHz to 2.5 GHz
 - BI221: 100 MHz to 5.0 GHz
- Measurement repetition rate: 1 μ s to 10 years
- Number of events per measurement point: 1 to 1×10^{18}
- Resolution:
 $\pm 8 ps(rms) \pm 1.4 \times TriggerErr$
- Accuracy: $\pm Resolution \pm TimebaseErr \pm 50 ps$

Period A or B

- Measures single periods of the signal
- Type: 1C2E (One-Channel Two-Edge)
- Range: 2.5 ns to 10 years
- Frequency range: DC to 400 MHz
- Time between measurements: 1 μ s to 10 years

- Resolution: $\pm 8 ps(rms) \pm 1.4 \times TriggerErr$
- Accuracy: $\pm Resolution \pm TimebaseErr \pm 100 ps$

Pulsewidth A or B

- Measures pulse widths of the signal
- Type: 1C2E (One-Channel Two-Edge)
- Range: 1 ns to 10 years
- Frequency range: DC to 400 MHz
- Time between measurements: 1 μ s to 10 years
- Resolution: $\pm 8 ps(rms) \pm 1.4 \times TriggerErr$
- Accuracy:
 $\pm Resolution \pm TimebaseErr \pm TriggerLevelTimeErr \pm 100 ps$

1-Ch Time Interval A or B

- Measures time intervals between edges of the input signal, with selectable polarity
- Type: 1C2E (One-Channel Two-Edge)
- Range: 1.25 ns to 10 years
- Frequency range: DC to 400 MHz
- Time between measurements: 1 μ s to 10 years
- Resolution: $\pm 8 ps(rms) \pm 1.4 \times TriggerErr$
- Accuracy:
 $\pm Resolution \pm TimebaseErr \pm TriggerLevelTimeErr \pm 100 ps$

Risetime A or B, Falltime A or B

- Measures risetime or falltime of the input signal
- Type: 1C2E (One-Channel Two-Edge)
- Two thresholds (trigger) levels are set
- Range: 0 ps to 10 years
- Frequency range: DC to 400 MHz
- Time between measurements: 1 μ s to 10 years
- Resolution: $\pm 8 ps(rms) \pm 1.4 \times TriggerErr$
- Accuracy:
 $\pm Resolution \pm TimebaseErr \pm TriggerLevelTimeErr \pm 100ps$

2-Ch Time Interval (TI2) A-to-B or B-to-A

- Measures the time between edges of signals from two channels
- Type: 2C2E (Two-Channel Two-Edge)
- Range: -500 ps to 10 years
- Frequency range: DC to 400 MHz
- Time between measurements: 1 μ s to 10 years
- Resolution:
 $\pm 8 ps(rms) \pm StartTriggerErr \pm StopTriggerErr$
- Accuracy:
 $\pm Resolution \pm TimebaseErr \pm TriggerLevelTimeErr \pm 100 ps$

Inputs and Outputs

Ch A and B

- Direct input (no prescaler):
 - ♦ Frequency range: DC to 400 MHz
 - ♦ Minimum pulse width: 1 ns
 - ♦ Coupling: DC
 - ♦ Input impedance: 1 M Ω to ground or 50 Ω into a user programmable termination voltage
 - ♦ Sensitivity: 50 mV rms sine, 50 mVp-p pulse
- Prescaled input (optional):
 - ♦ Frequency range:
 - BI220: 50 MHz to 2.5 GHz
 - BI221: 100 MHz to 5.0 GHz
 - ♦ Minimum pulse width:
 - BI220: 200 ps
 - BI221: 100 ps
 - ♦ Coupling: AC
 - ♦ Input impedance: 50 Ω into a user programmable termination voltage
 - ♦ Sensitivity: 30 mV rms sine, 30 mVp-p pulse
- Connector: SMA
- Termination voltage (Vt): -3 V to +3 V
 - ♦ Resolution: 100 μ V
 - ♦ Accuracy: 10 mV
- Trigger Threshold voltage (Vth): -5 V to +5 V
 - ♦ Resolution: 200 μ V
 - ♦ Accuracy: 10 mV
- Input voltage range:
 - ♦ Operating: -5 V to +5 V
 - ♦ Maximum (1 M Ω): -30 V to +30 V
 - ♦ Maximum (50 Ω): -5 V to 5 V DC, 5 Vrms AC (+27 dBm)
- Slope: Positive or negative
- Hysteresis – prevents false triggering by having separate threshold levels for rising and falling edges: 25 mV

EXTARM Input

- Connector: SMA
- Frequency range: DC to 400 MHz
- Minimum pulse width: 1 ns
- Hysteresis: 40 mV typical, fixed
- Setup time: 5 ns
- Impedance: 2 k Ω to ground (no programmable termination)
- Coupling: DC
- Trigger Threshold voltage (Vth): -5 V to +5 V
 - ♦ Resolution: 200 μ V
 - ♦ Accuracy: 10 mV
- Input voltage range:
 - ♦ Operating: -5 V to +5 V
 - ♦ Maximum: -10 V to +10 V
- Slope: Positive or negative

EXTCLK Input / CAL Output

- Connector: SMA
- Input for external timebase reference
 - ♦ Coupling: AC
 - ♦ Impedance: Programmable to 50 Ω or 5 k Ω
 - ♦ Amplitude:
 - Square wave – 400 mVp-p to 4 Vp-p
 - Sine wave – 1 Vp-p to 4 Vp-p
- Output for calibration signal (see manual for instructions)

Definitions

- TriggerErr or StartTriggerErr or StopTriggerErr
 - ♦ Error due to noise superimposed on the input signal from both internal and external sources
 - ♦
$$TriggerErr = \frac{\sqrt{300\mu V^2 + E_n^2}}{InputSignalSlewRate} \text{ s rms}$$
 - ♦ E_n = RMS noise of input signal (1GHz bandwidth)
 - ♦ InputSignalSlewRate = Slew rate of input signal (V/s) at the threshold point
- TriggerLevelTimeErr
 - ♦ Time error due to threshold uncertainty
 - ♦
$$TriggerLevelTimeErr = \frac{<10mV}{InputSignalSlewRate} \text{ s rms}$$
 - ♦ Example: For input signal slew rate = 100V/ μ s
TriggerLevelTimeErr = 100 ps
- TimebaseErr
 - ♦ Fractional Frequency error of timebase reference, times the measurement result

Arming

Each measurement run is composed of multiple blocks with multiple measurements in each block. For example, 200 blocks of 1000 pulsewidth measurements can be taken, for a total of 200,000 measurements. Statistical results are provided for each block, and for the whole set of blocks.

There are two separate arming settings – one for enabling blocks and one for enabling individual measurements.

Block Arm

- Mode
 - ♦ On Channel A edge (same polarity as measured edge)
 - ♦ On Channel B edge (same polarity as measured edge)
 - ♦ On EXT ARM rising or falling edge
 - ♦ By Time – every 1 μ s to 3.43 s, 12.8 ns resolution
 - ♦ Immediate – run as quickly as possible
 - ♦ By software command
- Number of blocks: 1 to 4x10¹⁵

Start Arm

Arms the start of each measurement point.

- Mode
 - ♦ By events – every set number of edges of the input signal
 - Number of events: 1 to 4,294,967,295
 - ♦ On Channel A edge (1C2E functions on Ch A only)

- ♦ On Channel B edge (1C2E functions on Ch B only)
- ♦ On EXT ARM rising or falling edge
- ♦ By Time – every 1 μ s to 3.43 s, 12.8 ns resolution
- ♦ Immediate – run as quickly as possible
- ♦ By software command
- Number of measurements per block: 1 to 4x10¹⁵

Stop Arm

- 1C1E functions: Not used
- 1C2E functions: Automatically configured for the specific function
- 2C2E functions: Stop Arm can be selected to occur either before or after the start edge of the signal

Timebase

- Standard internal oscillator:
 - ♦ TCXO (temperature compensated crystal oscillator)
 - ♦ Over full temperature range: ± 2 ppm
 - ♦ Aging: ± 2 ppm/year
- Optional NIST traceable internal 10 MHz oven oscillator:
 - ♦ Over full temperature range: ± 0.02 ppm
 - ♦ Aging: ± 0.001 ppm/day, ± 0.3 ppm/year
 - ♦ Warm-up time: 5 minutes
- External 10 MHz reference input
 - ♦ Frequency:
 - BI220: 10 MHz ± 50 ppm (± 500 Hz)
 - BI221 with std. osc: 10 MHz ± 3 ppm (± 30 Hz)
 - BI221 with oven osc: 10 MHz ± 0.5 ppm (± 5 Hz)
 - ♦ See “Inputs and Outputs” for signal characteristics
- PXI CLK10 (BI221 only)
 - ♦ Frequency requirements same as for External 10 MHz

Memory

- 128 MB on-board
 - ♦ Up to 11 million measurements in 1C1E functions
 - ♦ Up to 8 million measurements in 1C2E, 2C2E functions
- Memory can be read out while measurements are accumulating, allowing unlimited continuous measurements

Math and Statistics

- Performs additional mathematical operations on the measurement results
 - ♦ Scaling and normalizing
 - ♦ Calculating relative error
- Calculates statistics on blocks of measurements and on the total set of blocks
 - ♦ Mean, Min, Max, and Standard Deviation

Software

- Windows® and Linux driver
 - ♦ Provides a powerful set of functions for controlling the instruments and for data analysis
 - ♦ Includes tools for high speed reading of the instruments which take advantage of the PCI interface without burdening the user with the details
 - ♦ Windows® NT/95/98/2000/XP, 32 bit
 - ♦ Windows® Vista/7/8/10, 32/64-bit
 - ♦ Linux with 2.4/2.6 kernels (e.g. Redhat 3, Redhat 5), 32-bit
 - ♦ VBA (for use from excel®, used on some Teradyne testers)
 - ♦ Written in plain C++ for easy porting to other environments
- Virtual Front Panel (Windows® based)
 - ♦ Provides multiple simultaneous displays for the same measurement. The displays can even be different functions, as long as they are from the same group (1C1E, 1C2E, or 2C2E)
 - Graphs of results vs. time
 - Histogram
 - Numerical results (digital display)
 - Table of results and internal data
 - Streaming of results to a file
 - ♦ Can run multiple instruments of any model simultaneously
 - ♦ Compatible with Windows® XP/Vista/Win7 32/64-bit
 - ♦ Requires Microsoft™ .NET Framework 3.5 (included)

Computer Requirements

- BI220: One 32-bit 33 or 66 MHz PCI slot
- BI221: One 32-bit PXI slot
- Size:
 - ♦ BI220: 4.0”x6.8” (10.2x17.3cm) excluding bracket
 - ♦ BI221: 3U PXI
- 256 MB RAM, 500 MB disk space
- 800x600 minimum display resolution

Calibration

- Traceable calibration once a year
 - ♦ Requires a voltmeter and a frequency reference
- Internal calibration automatically calibrates the instrument against the internal voltage and frequency references

Power, Cooling and Physical

- Power supply requirements from PCI/PXI bus (typical):
 - ♦ BI220: 3.3 V @ 4.8 A 5 V @ 0.6 A
 12 V @ 0.3 A -12V @ 0A
 - ♦ BI221: 3.3V @ 3.0A 5V@ 0.6A
 12V @ 0.3A -12V @ 0.25A
- Total power consumption: 22 W typical
- Operating temperature range: 0°C to 45°C
- Good ventilation of slots in PC is recommended
- Weight:
 - ♦ BI220: 5 Oz (140 g)
 - ♦ BI221: 6.2 Oz (175 g)

Ordering Information

PN	Description
BI220	BI220 Time Interval Analyzer instrument, including software
BI221	BI221 Time Interval Analyzer instrument, including software
Opt-10	High performance timebase (oven oscillator) for both BI220 and BI221
Opt-20	2.5 GHz prescalers for BI220 (both channels) or 5.0 GHz prescalers for BI221 (both channels)

英里光电