

FEATURES

- BI401-2G: 1μHz to 2.1GHz Square Wave, Plus DC
- BI401-4G: 1μHz to 4.1GHz Square Wave, Plus DC
- Ultra-Low Phase Noise and Jitter (< 0.3ps)
 - ◆ See Phase Noise Plots Below
- Practically Perfect™ Frequency Resolution
 - ◆ 20 Digits
 - ◆ <1ps of Accumulated Drift Per Year!
- Frequency Switching Time: <250μs
- Differential Outputs (Can Use as Two Single Ended)
 - ◆ Up to 1Vpk-pk From -2V to +2.7V (50Ω Load)
 - ◆ PECL, ECL, LVDS Levels
 - ◆ 65ps Risetime
- Additional Single Ended Output
 - ◆ Up to 6Vpk-pk from -1V to +5V
 - ◆ CMOS Levels
- Unique Run-Time Level Calibration – Corrects for Load Termination Resistance
- Programmable, Glitch-Free Phase Switching
 - ◆ 0.3ps Resolution Regardless of Frequency
- Precision DC Output
- Internal Timebase Reference – Choice of Standard TCXO (2ppm) or Optional Oven (0.02ppm)
- Outputs of 10MHz or 100MHz Sine Wave or Square Wave Reference for Other Instruments

The Perfect Clock

The BI401 Clock Generator provides extremely accurate and stable square wave clock signals at up to 4.1GHz. Option -2G goes up to 2.1GHz, while -4G goes up to 4.1GHz. You can set the frequency with an unmatched resolution of 20 digits, and the jitter is below 0.3ps for all frequencies. There are two outputs – one single ended which provides up to 6Vpk-pk at 300MHz, and one differential with up to 1Vpk-pk at the full frequency range. The minimum frequency is 1μHz (one cycle in more than 11 days) and you can also output DC levels with 1mV accuracy. The instrument includes a high performance timebase and can serve as an excellent frequency reference for the whole system with very low phase noise. Both sine waves and square waves are available on the reference outputs. Figure 2 in the next page is a block diagram which shows the inputs and outputs that are available.

Ultra-Low Phase Noise and Jitter

Using advanced synthesizer technology, this instrument produces clock signals with very low phase noise. The time domain jitter is less than 0.3ps regardless of frequency. This is in direct contrast to sinewave generators (RF generators) whose jitter increases at low frequencies. For example, if you use a 2Vpk-pk 10MHz sinewave as a system clock, its slew rate is 62.8V/μs or 62.8mV/ns. Therefore, 1mv of noise will add 16ps of jitter. If this signal is a sampling clock for a 14-bit ADC, the ADC will be degraded significantly. Since the output of the BI401 is a square wave whose slew rate is the same for all frequencies, there is no added jitter at low frequencies.

APPLICATIONS

- Reference Clock for PLL Testing
- Sampling Clock for DACs and ADC
- Synchronization and Digital System Clock
- Low Jitter 1pps and Other Low Frequency Signals



BI401

Practically Perfect™ Frequency

You can set the frequency or the period of the signal with 20 digits of resolution. This means that even at 4GHz the resolution is 10^{-10} Hz (0.1 nHz), and at 1Hz the resolution is 10^{-20} Hz! This can be important in certain situations. As an example, suppose you want to generate a frequency which is one third of a 100MHz clock so that you have exactly one period of the generated signal for each three periods of the 100MHz clock. The period would be 30ns, and the frequency would be 33.33333...MHz. If the frequency can only be set with 12 digits of resolution you would end up with 1ps of drift every second which keeps accumulating so the phase between the signals will not be constant.

The reason that we call it “Practically Perfect™” is that a change in the least significant digit means a change of 1ps of total drift in more than a year – essentially not measurable. You never have to worry about getting the exact frequency.

Differential and Single Ended Outputs

As the block diagram (Fig 2) shows, there are two simultaneous outputs of the signal – A differential output (two SMA connectors) and a single ended output (one SMB connector).

Both sides of the differential output must be terminated with a 50Ω load. They can output a signal with amplitude of 0.1Vpk-pk to 1Vpk-pk over the range of -2V to +2.7V and they can be used as two single-ended outputs. This covers the range of logic levels for PECL (up to 3.3V), LVDS, and ECL running on a negative supply. The risetime is typically 65ps regardless of the output frequency.

The single ended (CMOS) output can drive unterminated lines up to 6Vpk-pk in the range of -1V to +5V. If the line is terminated by 50Ω the signal is half the amplitude. The risetime is typically 1ns, and the maximum frequency is 300MHz to 500MHz depending on the output amplitude. See the specifications for details.

Run-Time Level Calibration

The BI401 has a unique feature – it can correct the output voltage levels for variations due to your load resistance and any other error. This provides an unprecedented accuracy of 1mV for the output levels. Note that this is the total accuracy, not just the setting resolution. The feature can also be used to measure your load resistance.

Programmable Phase

The phase of the output signal can be set with a constant resolution of 0.3ps regardless of the output frequency. When you change the phase, the output is guaranteed to move to the new phase without any glitches.

Precision DC Output

The output can also be set to a constant DC voltage. When using the Run-Time Level Calibration feature, the accuracy is 1mV. The single ended output and the differential outputs can each drive up to 50mA.

High Performance Timebase

Since the output frequency is based on the timebase, the phase noise (jitter) of a clock generator is only as good as its timebase. The BI401 is based on an advanced multi-stage design which allows for selectable filtering of the external reference. The instrument also provides both sine wave and square wave outputs of the internal reference, either 10MHz or 100MHz.

Calibration

The BI401 has two internal references – a frequency reference (internal timebase oscillator), and a voltage reference. All other circuitry on the instrument is calibrated against these references using the included software. Once a year you need to calibrate these internal references using NIST traceable sources. The frequency reference can be any accurate 10MHz clock, and the voltage reference is a voltmeter (DMM).

Easy to Use Software

The software for the BI401 is included with the instrument. There is a driver for Windows and Linux and a front panel for Windows which allows you to control the instrument without any programming. The driver can also be used in old versions of Windows with old compilers including Borland C and Visual C 6.0. The software is designed for high performance with high level function calls. There is no need to learn register settings.

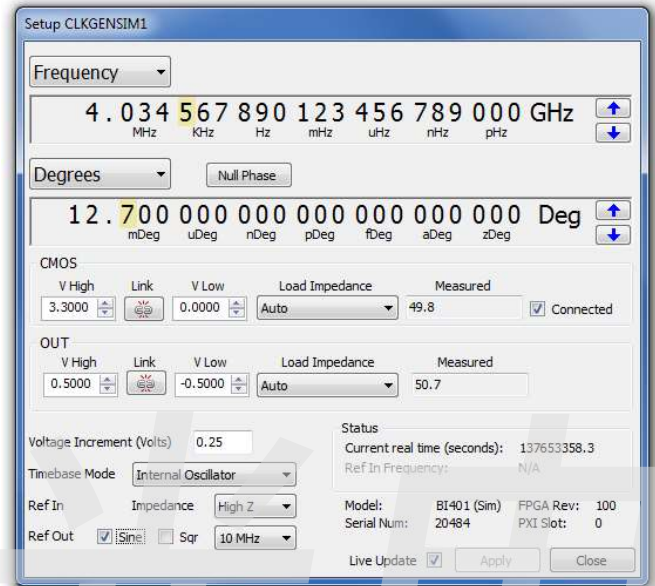

Figure 1: Virtual Front Panel for Windows

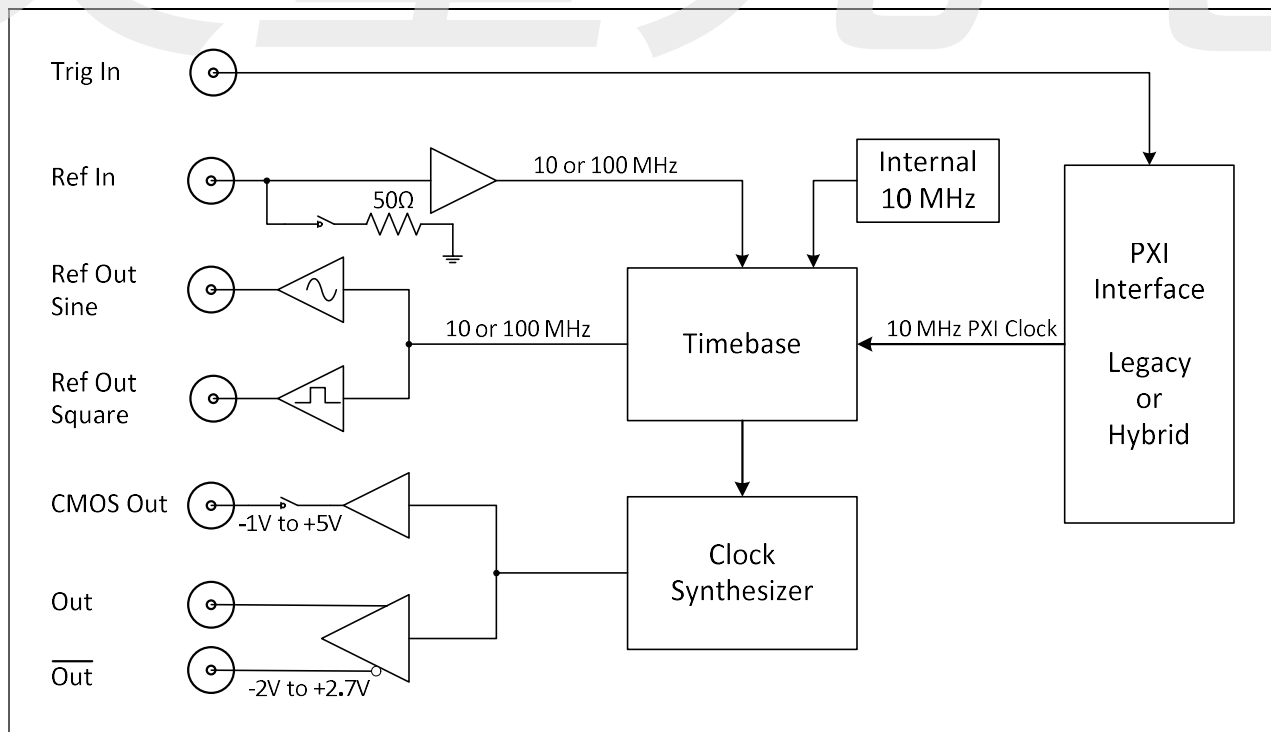

Figure 2: Simplified Block Diagram of the BI401

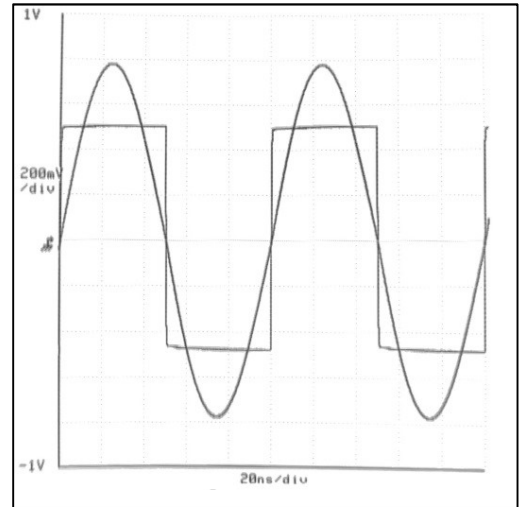

Figure 3: 10MHz Square and Sine Waves at 20ns/div

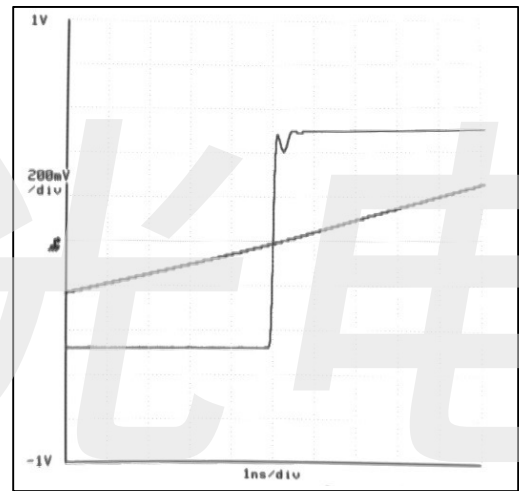

Figure 4: 10MHz Square and Sine Waves at 1ns/div

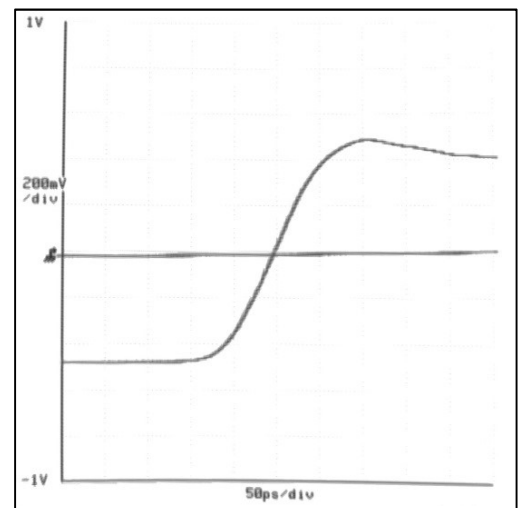

Figure 5: 10MHz Square and Sine Waves at 50ps/div

Square Wave Clocks are Better

The slew rate of a sine wave depends on the frequency and the amplitude.

$$SR = \pi f V_{pk-pk}$$

Where f is the frequency in Hz, and V_{pk-pk} is the peak-to-peak voltage. For example, a 1Vpk-pk 10MHz signal has a slew rate of $31.4 \times 10^6 \text{V/s}$, or $31.4 \text{V}/\mu\text{s}$.

The actual oscilloscope screen shots shown here are three views of the same 10MHz signals. One signal is a 1Vpk-pk square wave from a BI401, and the other is a 1.6Vpk-pk sine wave. The only difference between the three views is the time per division – from 20ns/div down to 50ps/div. Notice how at 20ns/div (Fig 3) the sine wave looks reasonably fast, not much different from the square wave. However, as we look closer, we find out that the sine wave is much slower than the square wave. The 1 ns/div view (Fig 4) shows how the slew rate of the sine wave is about $50 \text{V}/\mu\text{s}$, or $50 \text{mV}/\text{ns}$. At 50ps/div (Fig 5), the 65ps risetime of the BI401 output is clearly visible and in great contrast to the almost flat line of the sine wave.

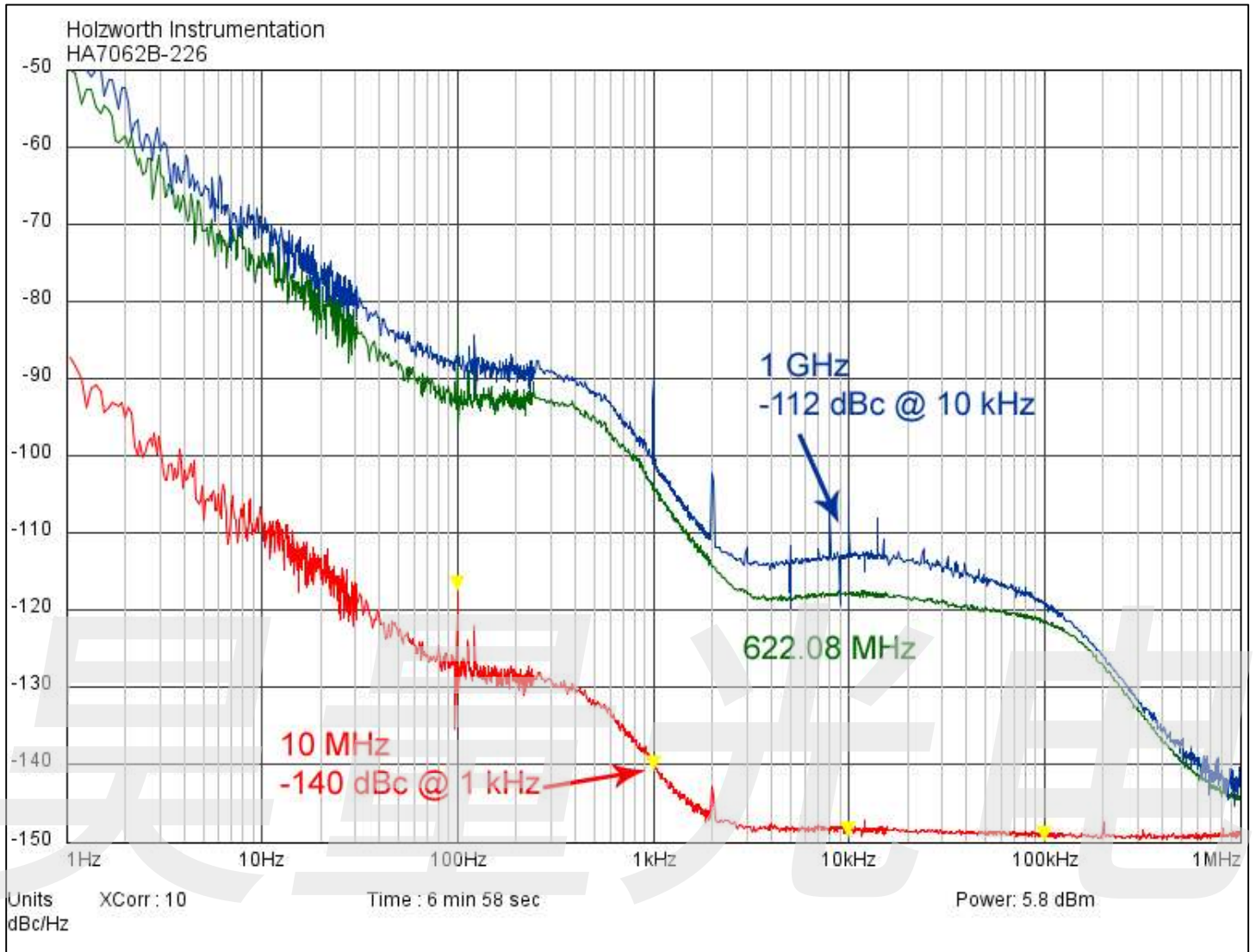

Figure 6: Actual phase noise measurement of a BI40I at 10 MHz, 622.08 MHz, and 1 GHz (all spurs shown).

SPECIFICATIONS

Frequency

- Range:
 - ♦ BI401-2G: 1μHz to 2.1GHz, plus DC
 - ♦ BI401-4G: 1μHz to 4.1GHz, plus DC
- Resolution: 20 digits
- Accuracy: Depends only on the accuracy of the timebase
 - ♦ When locked to an external reference, the frequency is perfectly accurate as a ratio of the timebase frequency
- Switching time: < 250μs

Timebase

- Standard internal oscillator:
 - ♦ TCXO (temperature compensated crystal oscillator)
 - ♦ Over full temperature range: ±2ppm
 - ♦ Aging: ±2ppm/year
- Optional NIST traceable internal 10MHz oven oscillator:
 - ♦ Over full temperature range: ±0.02ppm
 - ♦ Aging: ±0.001ppm/day, ±0.3ppm/year
 - ♦ Warm-up time: 5 minutes
- External timebase reference
 - ♦ Source:
 - PXI CLK10 (10MHz)
 - Ref In front panel (SMB connector)
 - ♦ Frequency:
 - Wide range filter setting: ±50ppm
 - 10MHz ±500Hz
 - 100MHz ±5kHz
 - Low noise filter setting:
 - Std. TCXO oscillator: ±5ppm
 - 10MHz ±50Hz
 - 100MHz ±500Hz
 - Optional oven oscillator: ±0.5ppm
 - 10MHz ±5Hz
 - 100MHz ±50Hz

Phase Noise

- See plots at end of specifications
- At 10MHz (dBc/√Hz):
 - ♦ 100 Hz offset: < -125
 - ♦ 1kHz offset: < -140
 - ♦ 10kHz offset: < -148
 - ♦ 100kHz offset: < -148
 - ♦ 10MHz offset: < -148
- At 622.08MHz (dBc/√Hz):
 - ♦ 100 Hz offset: < -91
 - ♦ 1kHz offset: < -103
 - ♦ 10kHz offset: < -117
 - ♦ 100kHz offset: < -121
 - ♦ 10MHz offset: < -140

- At 1GHz (dBc/√Hz):
 - ♦ 100 Hz offset: < -88
 - ♦ 1kHz offset: < -100
 - ♦ 10kHz offset: < -112
 - ♦ 100kHz offset: < -118
 - ♦ 10MHz offset: < -140

Jitter and Wander

- Jitter: < 0.3ps rms (1kHz to 10MHz bandwidth)
- Wander: < 10ps (10s persistence)

Phase Setting

- Guaranteed glitch-free
- Resolution
 - ♦ In time steps:
 - 0.3ps, regardless of frequency
 - ♦ In degrees: $1.1 \times 10^{-10} f$ (where f is frequency in Hz)
 - Examples:
 - At 4.1GHz: 0.45 deg.
 - At 1GHz: 0.11 deg.
 - At 1MHz: 0.00011 deg.
- Range: ±720 deg.
- Settling Time:
 - ♦ At frequency >100MHz: <100μs
 - ♦ At frequency < 100MHz: <3ms

Differential Outputs

- Frequency Range:
 - ♦ BI401-2G: DC to 2.1GHz
 - ♦ BI401-4G: DC to 4.1GHz
- Connectors: SMA
- Can be used as two separate single-ended outputs (if one side is not used, it should be terminated. 50 Ohm terminators are included with the instrument)
- High Level (Voh): -2V to +2.7V
- Amplitude (Voh – Vol): 200mVpk-pk to 1Vpk-pk
- Level Resolution: 300μV
- Level Accuracy:
 - ♦ With Run-Time Level Cal: 1mV
 - ♦ Without Run-Time Level Cal: 5mV
- Risetime (20% to 80%): 65ps typical
- Source Impedance: 50Ω (±1%)
- Load Impedance: 50Ω to ground is recommended on both outputs. The Run-Time Cal feature corrects for voltage level errors that are due to variation in load resistance

Single Ended Output (CMOS)

- Frequency Range:
 - ♦ Up to 1Vpk-pk amplitude: DC to 500MHz
 - ♦ Up to 3.3Vpk-pk amplitude: DC to 400MHz
 - ♦ Up to 6Vpk-pk amplitude: DC to 300MHz

- Connector: SMB
- High Level (Voh):
 - ♦ With high impedance load: -1V to +5V
 - ♦ With 50Ω load: -0.5V to +2.5V
- Amplitude (Voh – Vol): 200mVpk-pk to 6Vpk-pk
- Level Resolution: 600μV
- Level Accuracy:
 - ♦ With Run-Time Level Cal: 1mV
 - ♦ Without Run-Time Level Cal: 10mV
- Risetime (20% to 80%): 1ns typical
- Source Impedance: 50Ω (±1%)
- Load Impedance: Can vary from 50Ω to high impedance. The Run-Time Cal feature corrects for voltage level errors that are due to variation in load resistance

Reference Frequency Input and Output

- Ref In:
 - ♦ Input for a 10 MHz or 100 MHz reference frequency. Output frequency of instrument is based on this reference frequency when it is selected (see Timebase specifications)
 - ♦ Connector: SMB
 - ♦ Coupling: AC
 - ♦ Input impedance: 1kΩ or 50Ω, software selectable
 - ♦ Voltage range: 200mVpk-pk to 2Vpk-pk
 - ♦ Damage level: 4Vpk-pk
- Ref Out Sine:
 - ♦ Output of 10 MHz or 100 MHz sine wave
 - ♦ Connector: SMB
 - ♦ Coupling: AC
 - ♦ Voltage Level: >2.5Vpk-pk into 50Ω
- Ref Out Square:
 - ♦ Output of 10 MHz or 100 MHz square wave
 - ♦ Connector: SMB
 - ♦ Coupling: AC
 - ♦ Voltage Level: 3Vpk-pk into high impedance or 1.5Vpk-pk into 50Ω

Software

- Windows® and Linux driver
 - ♦ Provides high level functions for controlling the instrument
 - ♦ Windows® NT/95/98/2000/XP, 32 bit
 - ♦ Windows® Vista/7/8/10, 32/64-bit
 - ♦ Linux with 2.4/2.6 kernels (e.g. Redhat 3, Redhat 5), 32-bit
 - ♦ Can be used with VBA (for use from excel®, used on some Teradyne testers)
 - ♦ Written in plain C++ for easy porting to other environments
- Virtual Front Panel (Windows® based)
- Software updates will always be available free of charge

System Requirements

- One 32-bit PXI slot, legacy or hybrid
 - ♦ Size: 3U PXI (5.1"x7.3" including panel)
- 256 MB RAM, 500 MB disk space
- 800x600 minimum display resolution

Calibration

- Traceable calibration once a year
 - ♦ Requires a multimeter (DMM) and a frequency reference
- Internal calibration automatically calibrates the instrument against the internal voltage and frequency references

Power, Cooling and Physical

- Power supply requirements from PXI bus (maximum):
 - ♦ 3.3V @ 1A 5V @ 2A
 - ♦ 12V @ 0.8A -12V @ 0A
- Total power consumption (typical):
 - ♦ With std. timebase: 14W
 - ♦ With Opt-10 (oven oscillator):
 - Operating: 16W typical
 - Warm-up: 19W typical
- Operating temperature range: 0°C to 45°C
- Weight:
 - ♦ 6.4Oz (180g)

General

- Warranty: 2 years

Ordering Information

PN	Description
BI401-2G	2.1GHz Synthesized Clock Generator, including software
BI401-4G	4.1GHz Synthesized Clock Generator, including software
Opt-10	High performance timebase (oven oscillator)