



## PhaseLock

Universal phase locking / pulse timing controller

- Synchronization of a laser with electronic reference clocks or other lasers
- Arbitrary electronic phase scanning / pulse delay shifting
- Best solution for pump & probe experiments

## Application

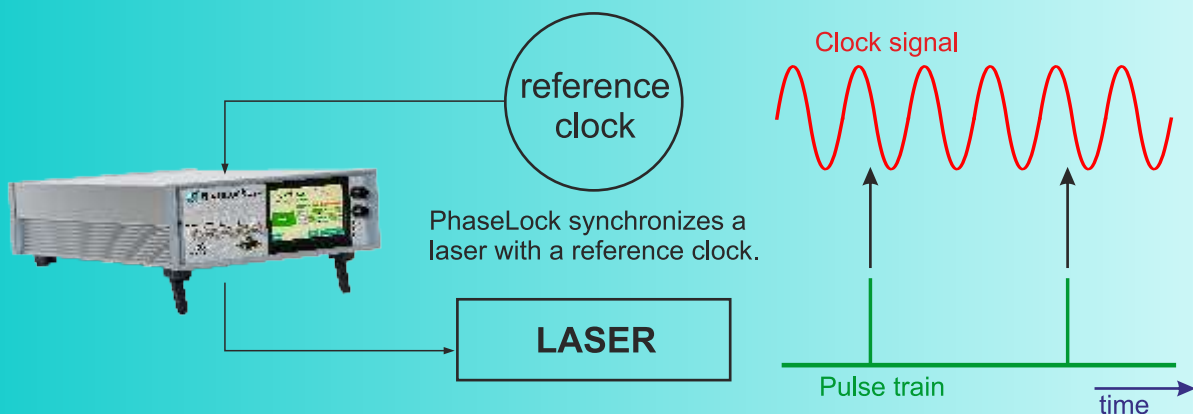

# PhaseLock

## Principle of Operation

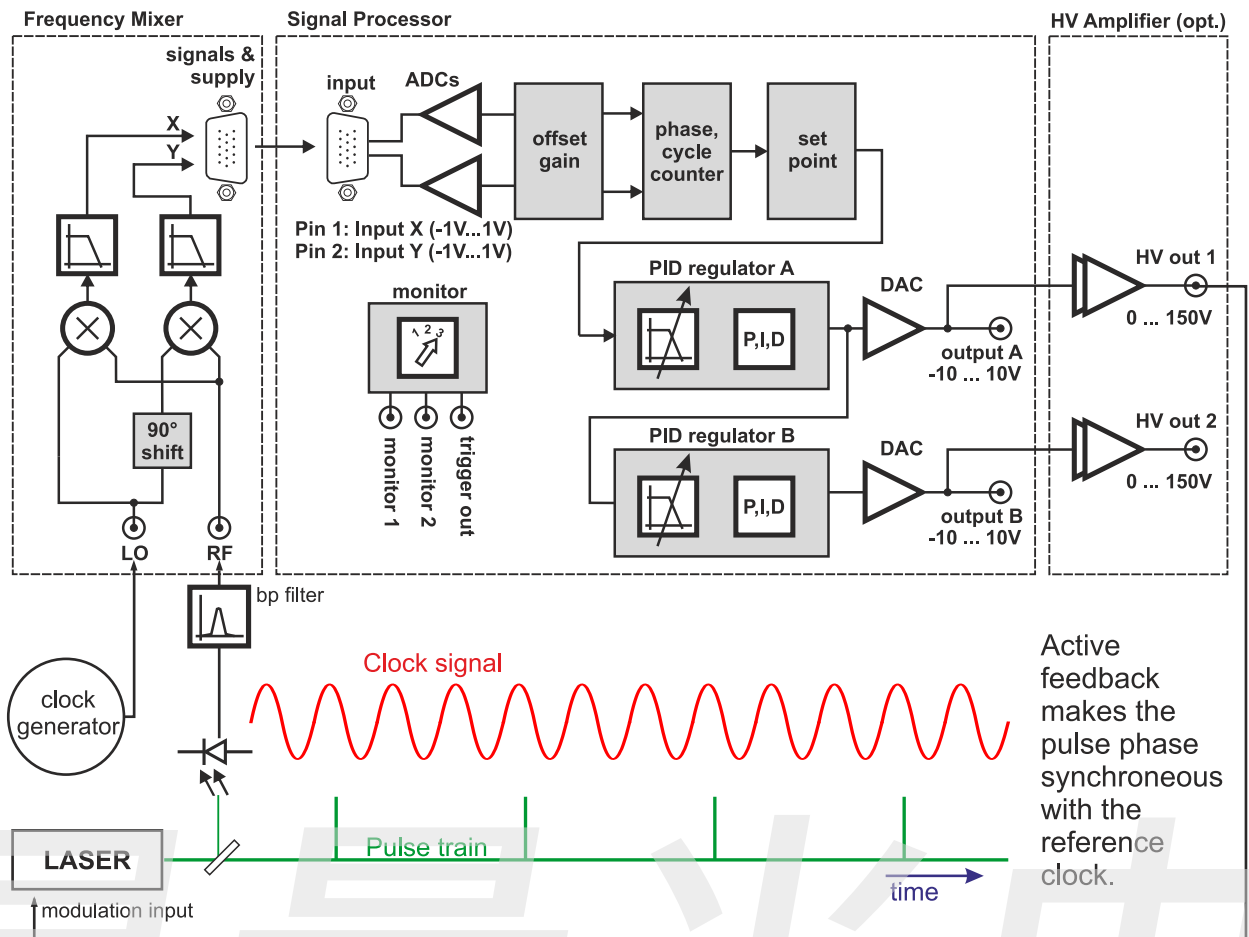

PhaseLock compares the pulse frequency of a laser with the frequency of some reference oscillator (a crystal oscillator, the clock of a synchrotron, or another pulsed laser, e.g.).

PhaseLock controls the laser in a way that both frequencies are always equal and stabilizes the relative phase of both oscillations. For a pulsed laser, the "phase" corresponds to the time at which the pulse occurs with respect to the period of the reference oscillation.

PhaseLock can adjust the relative phase to arbitrary values between 0 and  $2\pi$  and beyond (i.e., adjust the timing of the laser pulses to arbitrary values within one period of the reference signal or even shift it by multiples thereof).



PhaseLock desktop electronics



PhaseLock RF mixer / phase detector

PhaseLock can synchronize the pulse train of one laser with that of another laser. The pulse trains can be shifted relative to each other over several microseconds without moving elements. I. e., no mechanical delay stage is needed.

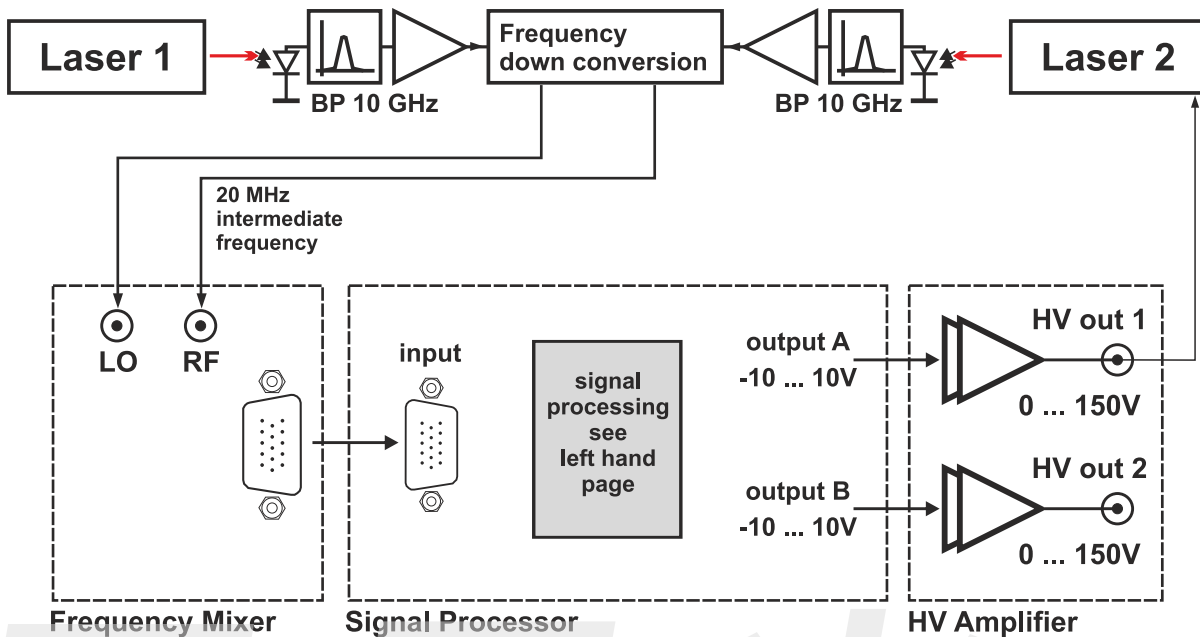

The RF frequency mixer used with PhaseLock requires sinusoidal input signals. For laser-to-laser locking, both pulse trains are converted to sine signals using bandpass filters. The selection of high harmonics near 10GHz results in a timing with single-femtosecond precision. A frequency converter generates a pair of sine/ cosine signals at an intermediate frequency near 20MHz suitable for the PhaseLock standard RF mixer / phase detector. This so called quadrature signal allows for arbitrary phase adjustment between both lasers. Thus, PhaseLock can shift the pulse trains of both lasers relative to each other over  $\pm 3\mu\text{s}$  without the necessity of a mechanical delay stage. The resolution is as low as 1.5fs.

Temporal shift of two pulse trains relative to each other without moving elements.

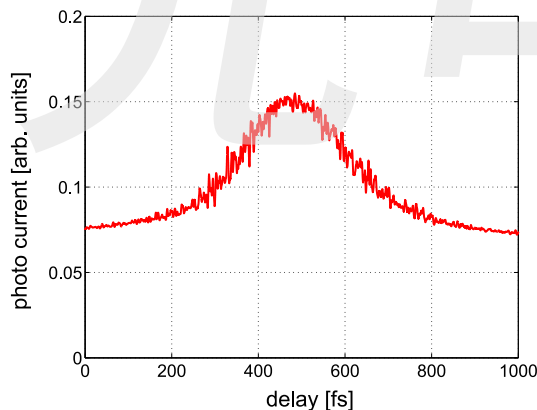

Superposition of two laser pulse trains on a nonlinear photo diode: photo current versus relative delay (crosscorrelation)

### Optional equipment

#### HV amp

- High voltage amplifier for PZT actuators
- Output voltage: 0...150V (others on request)
- Output current: 100mA / channel

#### PDR-1G

- Fast photo detector: bandwidth 900MHz
- Si or InGaAs photo diode
- Fiber coupled or free space optical input

#### PhaseLock 19"

PhaseLock in 19" rack case

- RF mixer built-in

#### Frequency down converter

- 10GHz high harmonics extraction for laser-to-laser synchronization
- Down conversion to intermediate frequency 19...21MHz
- Quadrature signal output

#### Nonlinear photodiodes

- For pulse overlap detection, e.g.
- Different wavelength ranges:

1550nm

1064nm

## Technical Data

<b>Signal input</b>	Impedance	50 Ohm
	Frequency range	20MHz ... 1GHz (others on demand)
	Power level of signal	typ. 0dBm (600mV pp), depends on application
	Power level of ref clock	+7 ... +10 dBm (1.5...2V pp)
	Sampling Rate	1.25 MS/s
<b>Outputs</b>	Over-all signal delay	< 5µs
	Voltage range	+/- 10.0 V at 1 kOhm load
	Impedance	50 Ohm
	Sampling Rate	1.25 MS/s, 14 bit
	(High voltage amplifier on demand.)	
<b>Phase detector</b>	Phase resolution	$2\pi / 65536 = 0.005^\circ$
	Phase adjustment range	$\pm 2\pi \times 32768 = 11796480^\circ$
	Cut-off frequency	300kHz
<b>Supply</b>	Voltage range	100...240 V AC, 50...60 Hz
	Power consumption	Typ. < 10 W, (20 W with HV option)
<b>Housing</b>	Desktop electronics	88mm x 260mm x 373mm (H x W x D)
	RF mixer (separate)	60mm x 130mm x 180mm
<b>Display</b>	Size	4.3" (11 cm)
	Resolution	480 x 272, 16-bit color
	Technology	resistive touchscreen, LED backlight

Subject to change without notice

Development, Manufacturing and Distribution



02/2019

