

Wavelength Combiners

L6Cc & L4Cc

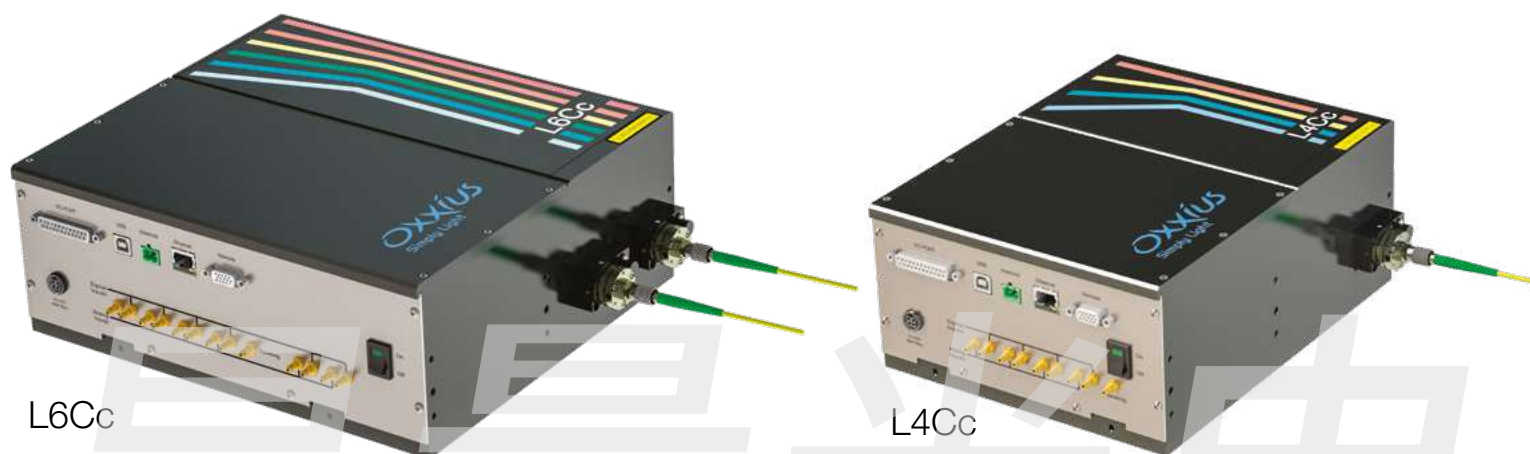

The L6Cc and L4Cc are the most compact and flexible all-in-one multicolor laser sources, with up to 7 laser lines and delivery up to 4 optical fiber outputs.

The modular design allows for a large choice of lasers from 375 up to 1064 nm and with output power up to 500 mW. The sources are Oxxius LaserBoxx or from other manufacturers.

The extension modules provide the ultimate level of flexibility by integrating fast switching output ports for FRAP, adjustable split power for light sheet microscopy among other advanced functionalities.

The L6Cc and L4Cc are field upgradeable to evolve as per your needs and to preserve your investment. They are microprocessor controlled to provide unique features for demanding applications.

The L6Cc and L4Cc are available in turnkey or OEM versions.

The L6Cc is also available in high power version, integrating LBX-HPE sources with up to 1.2 W output power per line. It is coupled into a speckle-free multimode fiber.

Super Resolution Imaging
 Single Molecule Localization
 Light Sheet
 STORM
 FRAP
 Confocal Microscopy
 Optogenetics
 Flow Cytometry

key features

- Up to 500 mW per wavelength
- Up to 4 output ports
- Direct modulation: analog, digital or both combined
- Linearized output power on Acousto-Optic Modulator (AOM)
- High efficiency Polarization Maintaining fiber coupling
- Multimode fiber coupling option
- Electro-mechanical shutter on each output and on each DPSS laser.
- USB computer interface
- compatible with μ -Manager environment

Benefits

- Up to 4 or 6 combined wavelengths
- Proven long-term stability
- Flexible configuration with extension Modules - unique for Oxxius
- Field upgradeable
- Comprehensive optical design for easy maintenance
- Extension modules with advanced features : dual output, fast switch mirror, AOTF, "+1 laser"
- Graphic User Interface software

375 405 445 450 473 488 505 515 520 532 553 561 594 633 638 640 642 647 660 730 785 980 1064

Description

When flexibility matters

Technical Simplicity - as per customer request

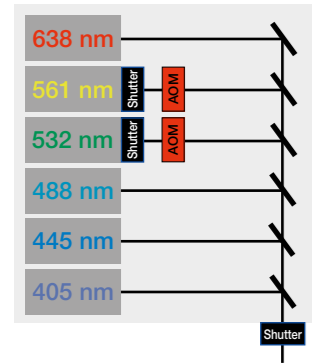

L6Cc and L4Cc integrate the largest panel of wavelengths from 375 up to 1064 nm combined in one channel or two independent channels.

The L4Cc and L6Cc can operate up to 4 or 6 lasers and up to 2 AOMs. The output power per laser line is as high as 220 mW at the end of single PM fiber.

Each DPSS and each output port come with an electro-mechanical shutter in standard. It is thus possible to block the beam without switching off the lasers.

Clean-up filters are provided in standard at 488 nm and 514 nm.

Multiple ports and "+1 laser" with advanced features are available with the extension modules (MDL).

Exceptional passive alignment stability is the result of a proven design based on short optical paths in conjunction with the ultra-low heat load of the Oxixus lasers.

Straightforward access to the optical components simplifies maintenance and future upgrades.



Output ports - Delivery options

The basic combiners feature one channel or two independent channels. They can be configured (or upgraded) with the extension modules (MDL) providing up to 4 ports and additional functionalities.

You can choose between free space beam delivery, Multimode, Single Mode or Polarization Maintaining fibers and any combination of them.

Fiber Coupling

Oxixus propose the compact SuK® or the user friendly Kineflex® fiber couplers with RGBV fiber at standard 0.12 numerical aperture. The fiber output options are FC/APC or FCP8 connectors or free space collimators on request.



Modulations and Controls

Each laser is modulated via independent analog and digital inputs.

The LBX/LPX laser sources are directly modulated with infinite extinction ratio. The LCX DPSS are modulated through an AOM. The output power from the AOM is linearized. The extinction ratio is higher than 45 dB.

If low speed modulation is needed, the OPT-FSTS offers digital modulation up to 200 Hz or OPT-MPA up to 10 Hz with 0-100% control of the output power.

If required, an AOTF is also available.

In standard, an electro-mechanical shutter is installed on each DPSS to block the beam without switching the laser off. The shutters are controlled via TTL signals or software commands.

The remote controller (RemoteBoxx) brings control elements at hand and the status within sight. The combiner can then be installed at the most convenient place.

The Oxixus software provides convenient Graphic User Interface for standalone use. The L4Cc and L6Cc are compatible with µManager environment.

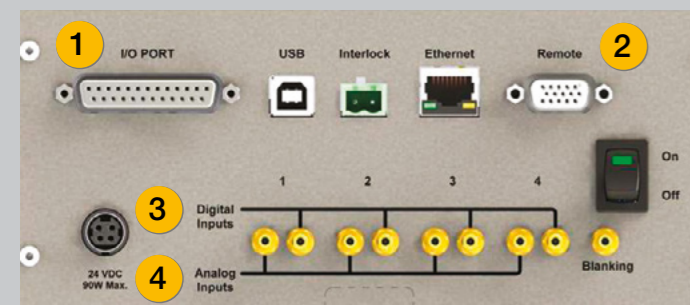

- 1** Input/Output port
 - Analog modulation inputs
 - 8 programmable inputs to drive electromechanical shutters, switch mirrors or other options
 - Interlock for microscope
- 2** RemoteBoxx socket
- 3** Digital and blanking modulation inputs
- 4** Analog modulation inputs

Select your sources

- 375 nm, 70 mW
- 405 nm, 50 up to 300 mW
- 445 nm, 100 mW
- 450 nm, 70 mW
- 473 nm, 300 mW
- 488 nm, 40 up to 200 mW
- 505 nm, 70 mW
- 515 nm, 150 mW
- 520 nm, 70 mW
- 532 nm, 50 up to 500 mW
- 553 nm, 50 up to 200 mW
- 561 nm, 50 up to 300 mW
- 594 nm, 50 & 100 mW
- 633 nm, 100 mW
- 638 nm, 100 up to 180 mW
- 640 nm, 300 up to 500 mW
- 642 nm, 130 mW
- 647 nm, 140 mW
- 660 nm, 100 mW
- 730 nm, 40 mW
- 785 nm, 100 up to 350 mW
- 980 nm, 200 mW
- 1064 nm, 100 up to 500 mW and more...

Notes:

- Each wavelength should be at least 10 nm apart
- RGBV fiber coupling - wavelength range 405-660 nm
- IRRGB Fiber coupling - wavelength range 450-730 nm
- RGBVUV Fiber coupling - wavelength range 375-638 nm

The L6Cc-HP, integrating LBX-HPE lasers (375 nm up to 940 nm), delivers up to 1.2W per line. Square fiber and speckle free output is provided by the ALBEDO unit from ERROL.

The L4Cc and L6Cc are flexible by design.

Versatility, at all levels, was in mind when our engineers designed the L4Cc and the L6Cc :

- The platform features up to two independent channels and can provide up to two output ports. The combiner is ready for docking with our pre-aligned extension modules.
- Our extension module is the unrivalled solution to seamlessly add new functionalities to Oxixus combiners.
- Using lasers with an industry standard footprint allows for the largest choice of wavelengths and powers.
- The electronic board embeds all functionalities as standard. Adding a second AOM or any other advanced features is effortless, simply plug it in and activate it.
- To fit the optical interface of microscopes, a large choice of connectors and collimators are available

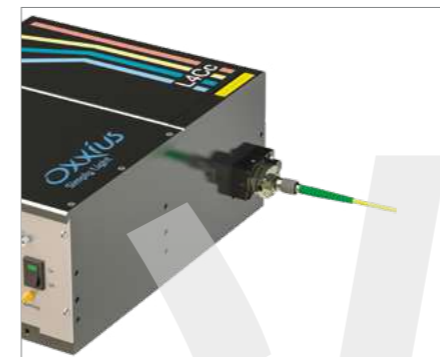

One-channel output

This is the most economical version with all embedded functionalities and still providing full capabilities for future upgrade.

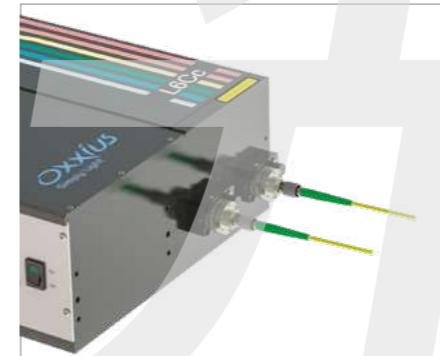

Two-channel outputs

The L4Cc and L6Cc can be set with two independent output ports. Each port will deliver one or several wavelengths.

This configuration is recommended for FRAP when additional independent 405 and 488 nm lasers are needed, or when UV or NIR lines are requested.

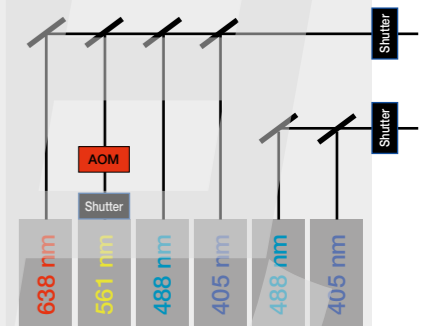

Extension Modules - get more from your combiner

With the extension modules (MDL), the L4Cc and L6Cc are offering advanced functionalities at a reasonable cost.

The electronic board embeds in standard the electrical connections and controls for the extension modules. The Modules are also pre-aligned and can be added on site.

Up to two Modules could be stacked to expand furthermore the possibilities.

- MDL-MDUAL** - Designed for light sheet microscopy. It provides two outputs with the possibility to balance the output power between each port. The split ratio accuracy is +/-5%.
- MDL-SPLIT** - Provides two outputs at fixed 50/50% ratio (+/-10% accuracy)
- MDL-FSTM** - Provides fast switching between two, three or four outputs at 30Hz (< 5 ms switching time)
- MDL-FLPM** - Recommended when only one L4Cc or L6Cc is used with two microscopes. This will economically route all lines on the selected output. This is not meant for frequent switching.
- MDL-L+1** - Provides one additional LBX laser, combined on the main channel or fully independent with its own output port.
- MDL-MNDF** - Provides a motorized neutral density filter when low output power is needed
- MDL-AOTF** - AOTF modulator - one output

Mechanical Drawings

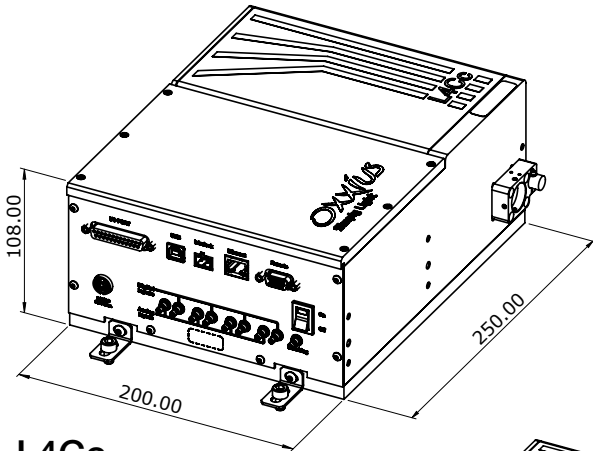

L4Cc

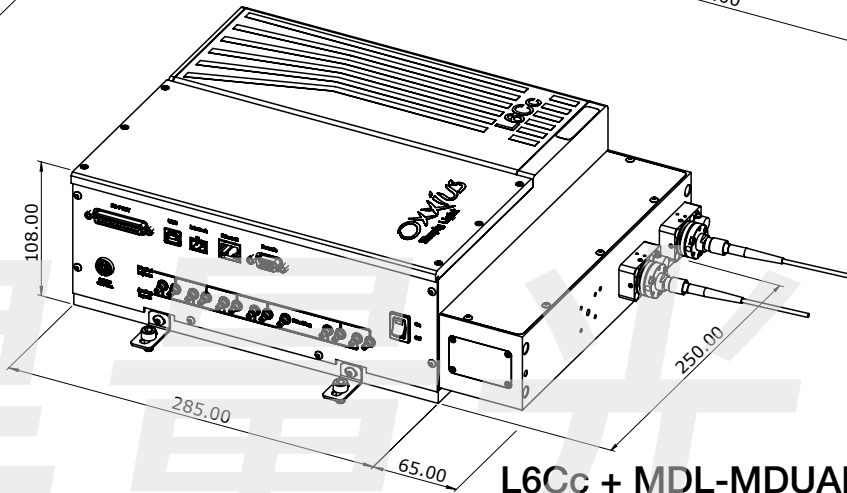
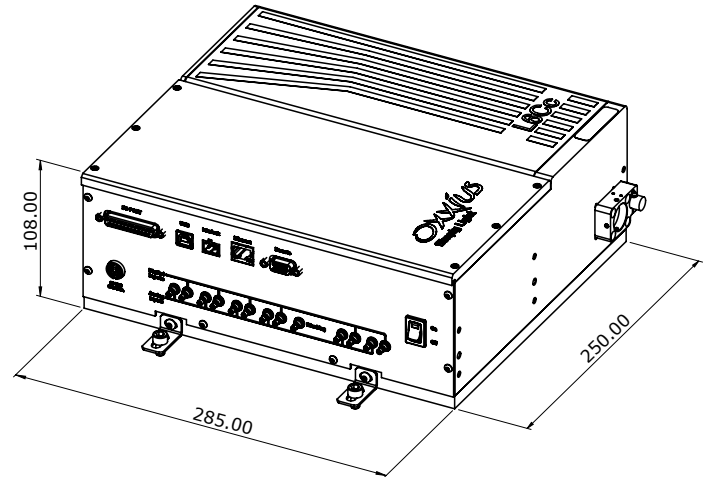

L6Cc + MDL-MDUAL

	L4Cc	L6Cc
Power stability (on RGBV range)		
Free space	±1% p-to-p	
PM fiber coupled	±2% p-to-p	
Modulation		
Analog (0 - 5V)	DC - 1 MHz	
Digital (TTL)	≤ 2 ns (LBX) / ≤ 1 μs (LCX with AOM)	
Extinction ratio	Infinite (LBX) / ≥ 45 dB (LCX with AOM)	
System specifications		
Operating temperature	15 - 40 °C (at baseplate)	
Power Consumption	60 W	100 W
Supply voltage P&P	100 -240 V AC	
Supply voltage	OEM 24 V DC	
Warm-up time 10 minutes	10 minutes	
Communication interfaces	USB, RS-232, dedicated I/O interface	
Software	Win 7, 8, 10 control software	
Weight	6.8 kg	9.3 kg

Packing list

- L4cc/L6cc bench including aligned laser sources and optical elements
- RemoteBoxx— remote control
- Clean up filter if ordered
- MDL-XXX-LnCc extension modules if ordered
- ACX-FCPM, SM or MM fiber coupling if ordered
- Test reports and initial setup configuration
- Printed user manual
- USB flashdrive with Oxxius softwares and manuals in PDFformat
- USB cable
- Tools
- Power supply and country selected power cord

Contact us:

Oxxius S.A.
4 rue Louis de Broglie
F-22300 Lannion, France

Phone: +33 296 48 70 28
Fax: +33 296 48 21 90
sales@oxxius.com
www.oxxius.com



VISIBLE AND INVISIBLE LASER
RADIATION
AVOID EXPOSURE TO BEAM
CLASS 3B LASER PRODUCT
Power up to 500 mW

VISIBLE AND INVISIBLE LASER
RADIATION
AVOID EYE OR SKIN EXPOSURE TO
DIRECT OR SCATTERED RADIATION
CLASS 4 LASER PRODUCT