

# Product Datasheet

## PLX Tool Cube™ - TC



The PLX Tool Cube is mounted in a housing that includes two adjustment knobs for leveling/aligning the tool cube.

It is available in two sizes, either 3" x 3" mirror faces or 5" x 5" mirror faces. Standard coating for the mirrors is a protected aluminum, customized coatings are also available.

The Tool Cube is typically used with two or more lasers or autocollimators to establish orthogonal axes.

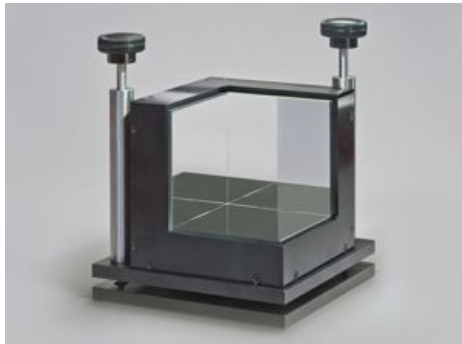

Specifications	
Substrate	Pyrex/Aluminum
Surface Quality	80-50 Scratch-Dig
Coating	Enhanced Aluminum
Wavelength (nm)	400 - 750
Reflectance	93%

### Tool Cube

The Tool Cube consists of three front surface mirrors that have been accurately assembled by a proprietary process into a mutually orthogonal inside corner. The PLX Tool Cube is designed for setting up optical axis or intuitive alignment of equipment and instruments at right angles to each other or parallel to each other. It has less than 1 arc-second deviation between any two adjacent mirrors.

### Outline Drawings

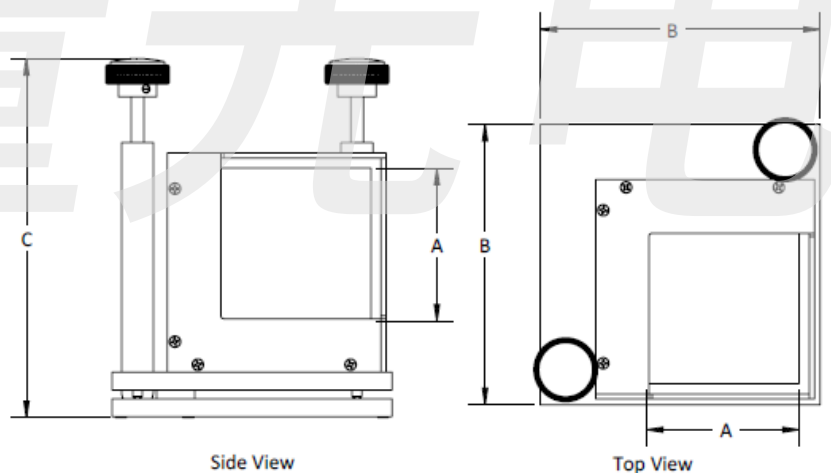

### Specifications

Item	Mirror Size	Weight
TC-30	3" x 3" (76 x 76 mm)	2.6 kg
TC-50	5" x 5" (127 x 127 mm)	5.5 kg

Item	A (in/mm)	B (in/mm)	C (in/mm)
TC-30	3.00/76.20	5.50/139.70	7.04/178.82
TC-50	5.00/127.00	7.75/196.85	9.29/235.97

#### Important Notice

This datasheet contains typical information specific to products manufactured at the time of its publication. All rights reserved. All material herein is the property of PLX Inc. and shall not be reproduced without the written permission of PLX Inc.

### Coating Curve

AOI 55°

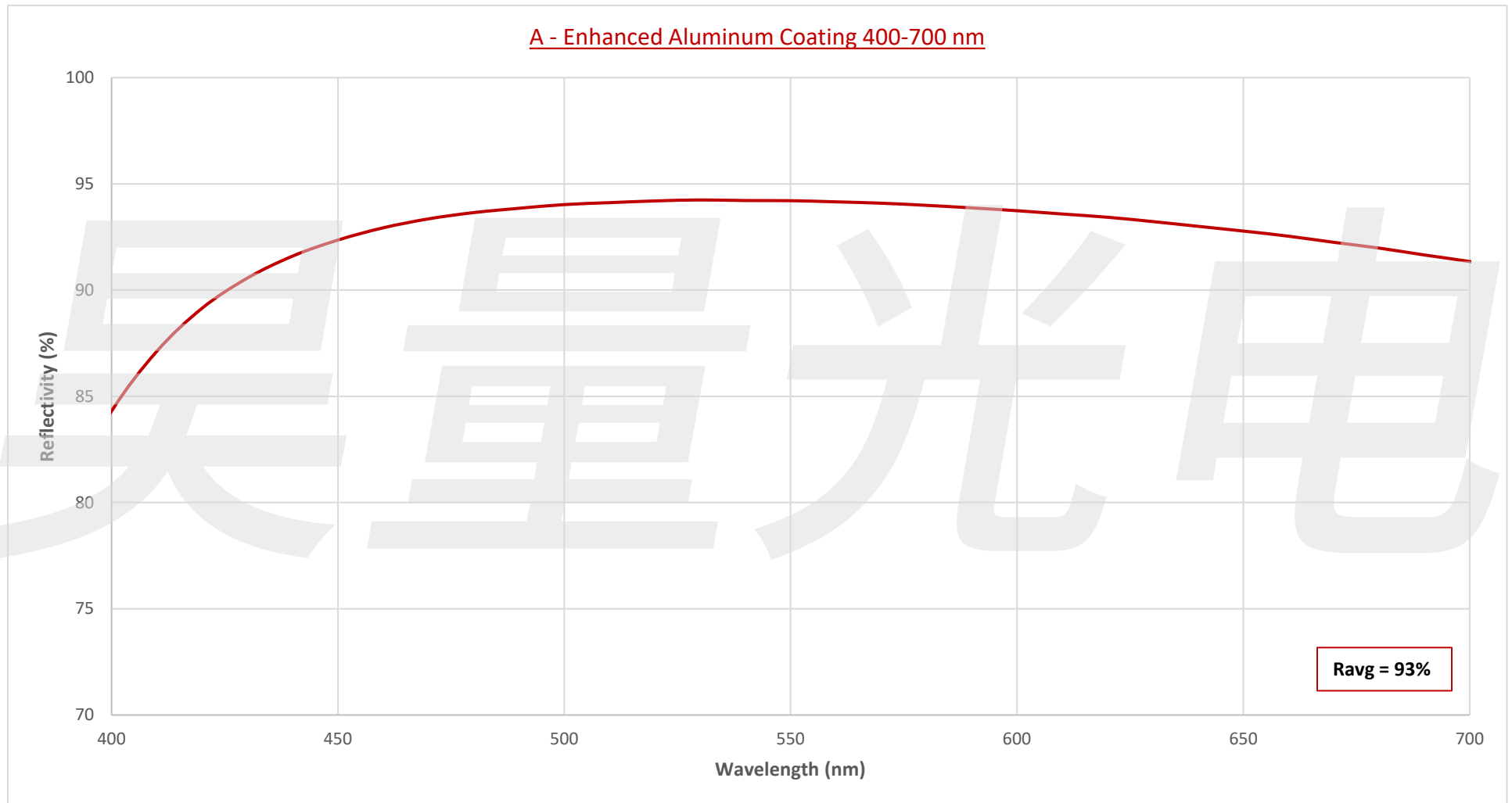

Coatings meet Ravg requirement, but coating curves are for reference as  $R(\lambda)$  may vary  $\pm 2\%$  per lot.