

Optical Testing. PLX electronic autocollimators can be used for testing various optical components. Some can be measured directly, and others would require the use of supplemental optics.

Boresighting. Boresighting is the aligning of a targeting system or systems with the barrel of a weapon, or the co-alignment of different targeting systems (visible and infrared). Boresighting will typically require some additional setup equipment.

PLX provides unique optical instruments, technologies, and solutions to problems of achieving and maintaining state-of-the-art optical accuracy and stability under severe environmental conditions.

Our proprietary Monolithic Optical Structure Technology (M.O.S.T.™) combines all the elements of a complex optical setup into a single monolithic unit, and is permanently aligned so it never needs adjustment, and will last indefinitely.

PLX is a registered ISO 9001 company and is fully compliant with ISO requirements. We design and manufacture products that meet demanding Military Specs.

Our extensive in-house manufacturing and environmental testing facilities, performance testing capabilities and state-of-the-art optical analysis equipment provide total quality management and accountability.

PLX products and systems are available in a wide variety of materials, mirror coatings, special metals, sizes, and configurations or can be customized to fit your specific requirements.



上海昊量光电设备有限公司
 官网: www.auniontech.com
 电话: 021-34241961
 邮箱: info@auniontech.com

PLX AUTOCOLLIMATORS



High-accuracy MEASUREMENT INSTRUMENTS capable of resolution down to FRACTIONS OF AN ARC-SECOND.

All PLX Autocollimators feature built-in lasers for course alignment and a base with leveling adjustments. Plus a software suite for recording and documenting measurements.

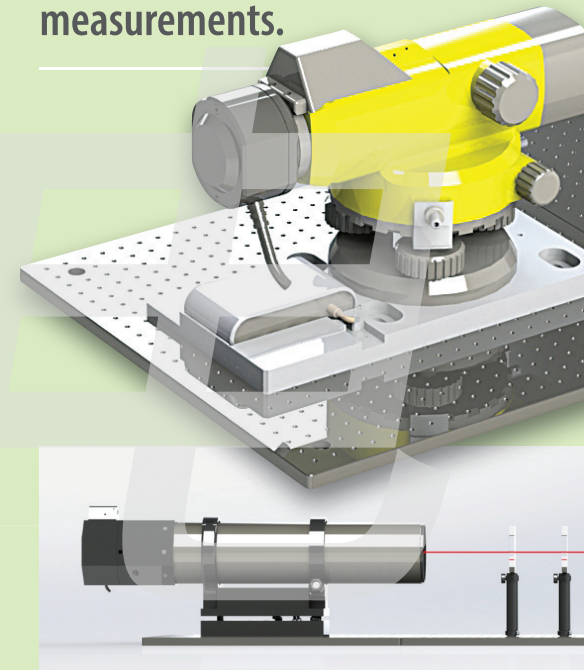

Primarily they are used to detect and measure small angular deviations.

Applications include:

Machinery Alignment. The Autocollimator/ Telescope can be used for checking the accuracy of machine slides as well as surface plate flatness.



The ACT-25B Autocollimator/Telescope

A high-accuracy measurement instrument capable of resolution down to fractions of an arc-second. The ACT-25B is designed as a complete system and is practically ready to use right out of the box.

Because of its high-quality CCD detector's high sensitivity, very faint back reflections will be captured and displayed.

When the ACT-25B is used as an autocollimator, the unit has a 40-minute horizontal measurement range. In alignment telescope mode, the field of view is 80 minutes horizontally. The PLX ACT-25B autocollimator has a 0.01 arc-second resolution.

A unique feature of the ACT-25B is the ability to focus down to less than 30cm (12 in) in telescope mode. This capability allows the measurement of lateral displacements, as opposed to the autocollimator mode which measures angular displacements.

Optional accessories for the ACT-25B include Hollow Retroreflectors, Lateral Transfer Hollow Retroreflectors™ (LTHR), Lateral Transfer Hollow Retroreflectors™ (LTHR) and Tool Cube.

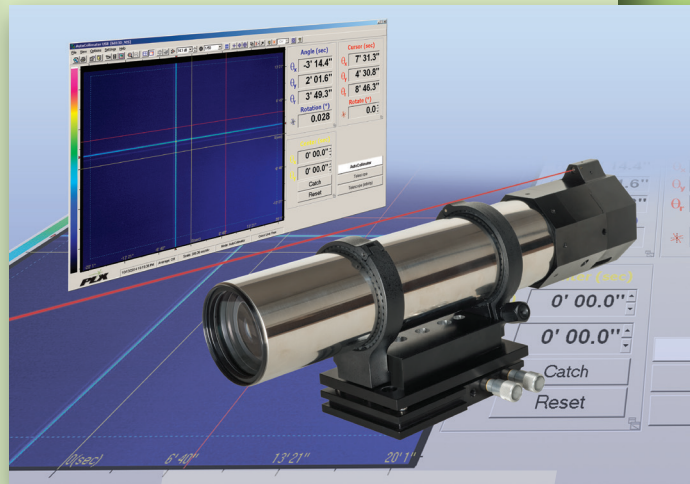

The ACT-HR High Resolution Autocollimator

Designed for use in tool rooms, inspection departments and quality control laboratories, the sensitive High-Resolution ACT-HR Electronic Autocollimator will measure extremely small angular displacements, squareness, twist and parallelism.

The ACT-HR performs high-precision reflection measurement from mirror surfaces down to 0.01 arc second. Some additional features include multiple results display, low light - low reflection capability, data logging with detailed statistics, video with playback snapshot files, software controlled electronic shutter and gain.



ACT-WF Wide Field of View Electronic Autocollimator

A rare combination of extreme resolution and wide field of view. It has a built-in computer controlled laser pointer for easy alignment as well as built-in pan and tilt adjusting mechanics.

The ACT-WF has a 2.4 megapixel wide spectral range camera, and features a resolution of 0.01 arc-seconds (0.05 μ Rad), with a clear aperture of 45mm, as well as real time measurement of angular displacement, low light low- reflection capability, data logging with detailed statistics, multiple results display, video logging, relative measurements and more.

The ACT-HR and ACT-WF can be utilized in numerous applications and a variety of areas including:

- Straightness measurement of linear stages
- Characterization of rotary stages
- Measurement of wedge, prism and polygon angles
- Measurement of reflecting surface parallelism
- Measurement of surface flatness
- Alignment of optical setups including lasers
- Measurement of mirror angles
- CD/DVD-Rom alignment
- Thermal stability measurements
- Vibrations analysis and much more.

PLX Tool Cube

The PLX Tool Cube is typically used with two or more lasers or autocollimators to establish orthogonal axes. It is set in a housing that includes two adjustment knobs for leveling and aligning the Tool Cube.

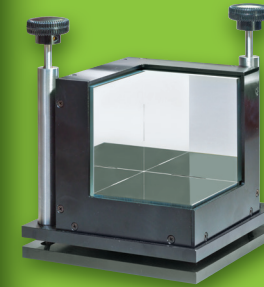

The PLX Tool Cube has less than 1 arc-second deviation between any two adjacent mirrors.

It is available in either 3" or 5" mirror faces. Standard coating for the mirrors is a protected aluminum, customized coatings are also available.

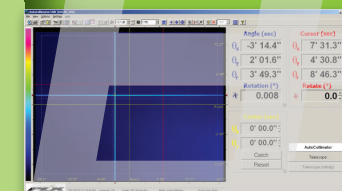

All PLX Electronic Autocollimators include a complete Software Suite

The software automatically displays angle deviation and can give the relative position of multiple targets.

Data logging is supported and can be configured to record for a predetermined time or a fixed number of data points. The recording interval can also be set. The data can be saved to a file or streamed to a remote location via RS-232 or TCP/IP. The communication setting for both RS-232 and TCP/IP is fully configurable from the software.

Besides taking interval measurements, the software supports video recording of the screen image for later playback and analysis.

上海昊量光电设备有限公司
 官网: www.auniontech.com
 电话: 021-34241961
 邮箱: info@ auniontech.com