

# Q1 series

## DIODE PUMPED AIR-COOLED Q-SWITCHED LASER

### FEATURES

Up to **45 mJ** pulse energy, up to **0.5 W** average output power

Up to **50 Hz** variable pulse repetition rate

Air cooled (**water-free**)

**7 – 10 ns** pulse duration

Weight < **5 kg** incl. power supply

> **2 G shot** lifetime of pump diode

Built-in sync pulse generator for triggering of user equipment

Remote monitoring and control via built-in **Ethernet** interface

Optional attachable PC controlled motorized attenuator

Optional attachable pulse energy monitor

Optional fiber coupled output

Optional stand-alone **2<sup>nd</sup>, 3<sup>rd</sup>, 4<sup>th</sup>** or **5<sup>th</sup>** harmonic generator

### APPLICATIONS

Laser Induced Breakdown Spectroscopy (LIBS)

Laser ablation

Time-of-Flight Spectroscopy (TOFS)

Light Induced Fluorescence (LIF) Spectroscopy

Non-linear laser spectroscopy

Flash photolysis

Photoacoustics

Metrology



Q1 is compact, energy-efficient, diode pumped, air-cooled, Q-switched laser designed for wide range of applications that require high peak power pulses.

Laser can produce up to 45 mJ at 10 Hz pulse repetition rate or up to 10 mJ at 50 Hz pulse repetition rate. Low divergence of laser beam allows efficient conversion to harmonic wavelengths using optional H1 series harmonic generator module.

The laser can configured to emit 1053 nm or 1064 nm wavelength from Nd:YLF or Nd:YAG laser crystals respectively. Due athermal properties of Nd:YLF crystal, at 1053 nm the laser can operate from single shot to maximum pulse repetition rate without significant changes in beam divergence or profile.

Innovative laser design resulted in user-friendly turnkey system that requires little maintenance. There is no chillers or bulky power supplies that one needs fit under the table. All laser electronics is integrated into Q1 housing and the only external modules are lightweight controller box that provides laser control interfaces and mains adapter that provides 12 VDC powering. Total weight of the laser is less than 5 kg.



Quantum  
Light  
Instruments

Laser is monitored and controlled through Ethernet port via built-in web-server. Any computer or even cell phone with modern web-browser will be able to control Q1. API is provided for integration with user devices.

Low jitter triggering pulses for user equipment are available with up to 300  $\mu$ s lead in internal triggering mode. In external triggering mode, laser pulsing can be externally triggered from delay generator.

Laser functionality can be further extended by wide selection of auxiliary equipment:

- Up to fifth harmonic output can be produced from our stand-alone H1 series harmonic generators.
- Pulse energy can be adjusted with our motorized attenuator for fundamental wavelength beam.
- Pulse energy can be monitored by our attachable pulse energy monitor with analog and/or digital output.
- Fiber coupled output is available by request. Please inquire for detailed specifications.

## SPECIFICATIONS AT 10 Hz PULSE REPETITION RATE <sup>1)</sup>

MODEL	Q1			
	-B10	-C10	-D10	-E10
Wavelength	1053 or 1064 nm		1064 nm	1053 nm
Pulse repetition rate <sup>2)</sup>	Single-shot to 10 Hz			
Pulse duration <sup>3)</sup>	< 8 ns		< 7 ns	
Pulse energy <sup>4)</sup>				
1053 / 1064 nm	10 mJ	20 mJ	35 mJ	45 mJ
526.5 / 532 nm	5 mJ	10 mJ	17 mJ	22 mJ
351 / 355 nm	3 mJ	6 mJ	10 mJ	13 mJ
263 / 266 nm	1.5 mJ	3 mJ	5 mJ	7 mJ
211 / 213 nm	0.5 mJ	1 mJ	2 mJ	2.5 mJ
Pulse to pulse energy stability <sup>5)</sup>				
1053 / 1064 nm	<0.5 % RMS			
526.5 / 532 nm	<2.5 % RMS			
351 / 355 nm	<3.5 % RMS			
263 / 266 nm	<4 % RMS			
211 / 213 nm	<5 % RMS			
Power drift <sup>6)</sup>	$\pm$ 3.0 %			
Beam profile	Bell-shaped, >75 % fit to Gaussian			
Beam divergence <sup>7)</sup>	<1 mrad			
Beam pointing stability <sup>8)</sup>	< 10 $\mu$ rad			
Polarization	Linear, horizontal			
Typical beam diameter <sup>9)</sup>	1.7 mm	2.5 mm	3.5 mm	
Jitter <sup>10)</sup>	< 0.5 ns RMS			
OPTIONAL ATTENUATOR <sup>11)</sup>				
Transmission range	0.5 – 95 %			
DIMENSIONS				
Laser head (W×L×H)	110 × 231 × 112 mm <sup>3</sup>			
Controller unit (W×L×H)	108 × 191 × 59 mm <sup>3</sup>			
Power adapter (W×L×H) <sup>12)</sup>	50 × 125 × 31 mm <sup>3</sup>			
Harmonic generator (W×L×H) <sup>13)</sup>	110 × 242 × 112 mm <sup>3</sup>			
OPERATING REQUIREMENTS				
Cooling requirements	Air cooled			
Ambient temperature	15 – 30 °C			
Relative humidity	10 – 80 % (non-condensing)			
Mains voltage	90 – 230 VAC, single phase, 47 – 63 Hz <sup>14)</sup>			
Average power consumption	15 W	25 W	30 W	

<sup>1)</sup> Due to continuous improvements all specifications are subject to change. Unless stated otherwise all specifications are measured at fundamental wavelength and maximum pulse repetition rate. The parameters marked typical are not specifications. They are indications of typical performance and will vary with each unit we manufacture.

<sup>2)</sup> Factory-set pulse repetition rate is fixed at max repetition rate shown in the table. Smoothly variable pulse repetition rate is possible when laser is externally triggered. In internal triggering mode repetition rate can be divided by integer number down to f/2, f/3, f/4, ... 1 Hz.

<sup>3)</sup> At FWHM level at fundamental wavelength, measured with 350 ps rise time photodiode.

<sup>4)</sup> Pulse energies for harmonic wavelengths are maximum possible values available from H1 series harmonic generator module. See datasheets of H1 for details.

<sup>5)</sup> Measured during 30 seconds operation after warm-up.

<sup>6)</sup> Over 8 hour period after 20 minutes of warm-up when ambient temperature variation is less than  $\pm$ 2 °C.

<sup>7)</sup> Full angle measured at the 4 $\sigma$  level.

<sup>8)</sup> Peak to peak value, measured for 30 seconds of operation after laser warm-up.

<sup>9)</sup> Beam diameter is measured 20 cm from laser output at the 4 $\sigma$  level.

<sup>10)</sup> In respect to falling edge of pump diode triggering pulse.

<sup>11)</sup> Motorized attenuator intended to be attached to the laser housing. Transmission can be changed remotely through laser web-server control interface.

<sup>12)</sup> Power adapter dimensions might differ from indicated here, depending on model.

<sup>13)</sup> Q1 laser is compatible all models of stand-alone H1 harmonics generator. Please refer to harmonic generator datasheets for detailed specifications.

<sup>14)</sup> Laser can be powered from appropriate 12 VDC power source. Please inquire for details.



## SPECIFICATIONS AT 20 Hz PULSE REPETITION RATE <sup>1)</sup>

MODEL	Q1		
	-B20	-C20	-D20
Wavelength	1053 or 1064 nm		
Pulse repetition rate <sup>2)</sup>	Single-shot to 20 Hz		
Pulse duration <sup>3)</sup>	< 8 ns		
Pulse energy <sup>4)</sup>			
1053 / 1064 nm	8 mJ	15 mJ	25 mJ
526.5 / 532 nm	4 mJ	7.5 mJ	12.5 mJ
351 / 355 nm	2.5 mJ	5 mJ	7.5 mJ
263 / 266 nm	1 mJ	1.8 mJ	3 mJ
211 / 213 nm	0.4 mJ	0.7 mJ	1.2 mJ
Pulse to pulse energy stability <sup>5)</sup>			
1053 / 1064 nm	<0.5 % RMS		
526.5 / 532 nm	<2.5 % RMS		
351 / 355 nm	<3.5 % RMS		
263 / 266 nm	<4 % RMS		
211 / 213 nm	<5 % RMS		
Power drift <sup>6)</sup>	± 3.0 %		
Beam profile	Bell-shaped, >75 % fit to Gaussian		
Beam divergence <sup>7)</sup>	<1.5 mrad		
Beam pointing stability <sup>8)</sup>	< 20 μrad		
Polarization	Linear, horizontal		
Typical beam diameter <sup>9)</sup>	1.7 mm	2.0 mm	2.5 mm
Jitter <sup>10)</sup>	< 0.5 ns RMS		
OPTIONAL ATTENUATOR <sup>11)</sup>			
Transmission range	1 – 95 %		
DIMENSIONS			
Laser head ( W×L×H)	110 × 231 × 112 mm <sup>3</sup>		
Controller unit ( W×L×H)	108 × 191 × 59 mm <sup>3</sup>		
Power adapter ( W×L×H) <sup>12)</sup>	50 × 125 × 31 mm <sup>3</sup>		
Harmonic generator ( W×L×H) <sup>13)</sup>	110 × 242 × 112 mm <sup>3</sup>		
OPERATING REQUIREMENTS			
Cooling requirements	Air cooled		
Ambient temperature	15 – 30 °C		
Relative humidity	10 – 80 % (non-condensing)		
Mains voltage	90 – 230 VAC, single phase, 47 – 63 Hz <sup>14)</sup>		
Average power consumption	30 W		

<sup>1)</sup> Due to continuous improvements all specifications are subject to change. Unless stated otherwise all specifications are measured at fundamental wavelength and maximum pulse repetition rate. The parameters marked typical are not specifications. They are indications of typical performance and will vary with each unit we manufacture.

<sup>2)</sup> Factory-set pulse repetition rate is fixed at max repetition rate shown in the table. Smoothly variable pulse repetition rate is possible when laser is externally triggered. In internal triggering mode repetition rate can be divided by integer number down to  $f/2, f/3, f/4, \dots$  1 Hz.

<sup>3)</sup> At FWHM level at fundamental wavelength, measured with 350 ps rise time photodiode.

<sup>4)</sup> Pulse energies for harmonic wavelengths are maximum possible values available from H1 series harmonic generator module. See datasheets of H1 for details.

<sup>5)</sup> Measured during 30 seconds operation after warm-up.

<sup>6)</sup> Over 8 hour period after 20 minutes of warm-up when ambient temperature variation is less than ±2 °C.

<sup>7)</sup> Full angle measured at the 4σ level.

<sup>8)</sup> Peak to peak value, measured for 30 seconds of operation after laser warm-up.

<sup>9)</sup> Beam diameter is measured 20 cm from laser output at the 4σ level.

<sup>10)</sup> In respect to falling edge of pump diode triggering pulse.

<sup>11)</sup> Motorized attenuator intended to be attached to the laser housing. Transmission can be changed remotely through laser web-server control interface.

<sup>12)</sup> Power adapter dimensions might differ from indicated here, depending on model.

<sup>13)</sup> Q1 laser is compatible all models of stand-alone H1 harmonics generator. Please refer to harmonic generator datasheets for detailed specifications.

<sup>14)</sup> Laser can be powered from appropriate 12 VDC power source. Please inquire for details.



Laser head Q1 with attached harmonic generator module H1

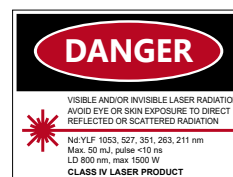

Laser head Q1 with controller unit

# SPECIFICATIONS AT 50 Hz PULSE REPETITION RATE <sup>1)</sup>

MODEL	Q1		
	-50	-A50	-B50
Wavelength	1053 or 1064 nm		
Pulse repetition rate <sup>2)</sup>	Single-shot to 50 Hz		
Pulse duration <sup>3)</sup>	< 10 ns	< 9 ns	< 8 ns
Pulse energy <sup>4)</sup>			
1053 / 1064 nm	2.5 mJ	5 mJ	10 mJ
526.5 / 532 nm	1.2 mJ	2.5 mJ	5 mJ
351 / 355 nm	0.6 mJ	1.5 mJ	3 mJ
263 / 266 nm	0.3 mJ	0.7 mJ	1.5 mJ
211 / 213 nm	0.1 mJ	0.2 mJ	0.5 mJ
Pulse to pulse energy stability <sup>5)</sup>			
1053 / 1064 nm	<0.5 % RMS		
526.5 / 532 nm	<2.5 % RMS		
351 / 355 nm	<3.5 % RMS		
263 / 266 nm	<4 % RMS		
211 / 213 nm	<5 % RMS		
Power drift <sup>6)</sup>	± 3.0 %		
Beam profile	Nearly TEM <sub>00</sub> , >80 % fit to Gaussian		
Beam divergence <sup>7)</sup>	<1.5 mrad		
Beam pointing stability <sup>8)</sup>	< 20 μrad		
Polarization	Linear, horizontal		
Typical beam diameter <sup>9)</sup>	1.0 mm	1.3 mm	1.5 mm
Jitter <sup>10)</sup>	< 0.5 ns RMS		
OPTIONAL ATTENUATOR <sup>11)</sup>			
Transmission range	1 – 95 %		
DIMENSIONS			
Laser head ( W×L×H)	110 × 231 × 112 mm <sup>3</sup>		
Controller unit ( W×L×H)	108 × 191 × 59 mm <sup>3</sup>		
Power adapter ( W×L×H) <sup>12)</sup>	50 × 125 × 31 mm <sup>3</sup>		
Harmonic generator ( W×L×H) <sup>13)</sup>	110 × 242 × 112 mm <sup>3</sup>		
OPERATING REQUIREMENTS			
Cooling requirements	Air cooled		
Ambient temperature	15 – 30 °C		
Relative humidity	10 – 80 % (non-condensing)		
Mains voltage	90 – 230 VAC, single phase, 47 – 63 Hz <sup>14)</sup>		
Average power consumption	<40 W		

- <sup>1)</sup> Due to continuous improvements all specifications are subject to change. Unless stated otherwise all specifications are measured at fundamental wavelength and maximum pulse repetition rate. The parameters marked typical are not specifications. They are indications of typical performance and will vary with each unit we manufacture.
- <sup>2)</sup> Factory-set pulse repetition rate is fixed at max repetition rate shown in the table. Smoothly variable pulse repetition rate is possible when laser is externally triggered. In internal triggering mode repetition rate can be divided by integer number down to f/2, f/3, f/4, ... 1 Hz.
- <sup>3)</sup> At FWHM level at fundamental wavelength, measured with 350 ps rise time photodiode.
- <sup>4)</sup> Pulse energies for harmonic wavelengths are maximum possible values available from H1 series harmonic generator module. See datasheets of H1 for details.
- <sup>5)</sup> Measured during 30 seconds operation after warm-up.
- <sup>6)</sup> Over 8 hour period after 20 minutes of warm-up when ambient temperature variation is less than ±2 °C.
- <sup>7)</sup> Full angle measured at the 4σ level.
- <sup>8)</sup> Peak to peak value, measured for 30 seconds of operation after laser warm-up.
- <sup>9)</sup> Beam diameter is measured 20 cm from laser output at the 4σ level.
- <sup>10)</sup> In respect to falling edge of pump diode triggering pulse.
- <sup>11)</sup> Motorized attenuator intended to be attached to the laser housing. Transmission can be changed remotely through laser web-server control interface.
- <sup>12)</sup> Power adapter dimensions might differ from indicated here, depending on model.
- <sup>13)</sup> Q1 laser is compatible all models of stand-alone H1 harmonics generator. Please refer to harmonic generator datasheets for detailed specifications.
- <sup>14)</sup> Laser can be powered from appropriate 12 VDC power source. Please inquire for details.

## DRAWINGS

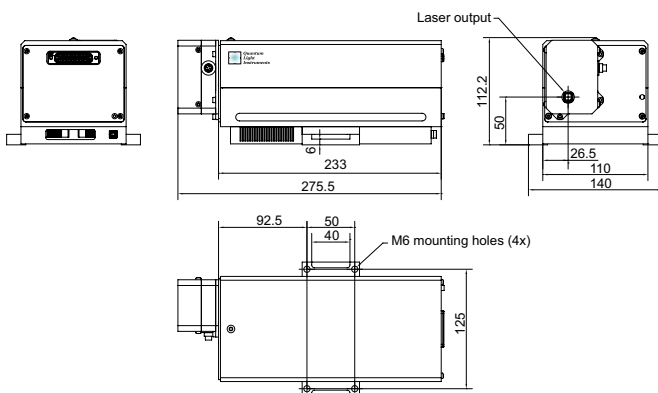

Laser head with attachable motorized attenuator dimensions (in mm)



## AUXILIARY EQUIPMENT

Stand-alone H1 series harmonic generators for down to 211 nm output

Attachable motorized attenuator for fundamental wavelength beam

Attachable pulse energy monitor with analog and/or digital output

上海昊量光电设备有限公司

中国区代理

官网: www.auniontech.com 电话: 185 0177 0670

邮箱: jiabin-wei@auniontech.com

地址: 上海市徐汇区漕宝路 86 号光大会展中心 F 座 3 楼

Quantum Light Instruments Ltd.

Mokslininku 6A

LT-08412, Vilnius, Lithuania