

Q2 series

DIODE PUMPED AIR-COOLED Q-SWITCHED LASER

FEATURES

Up to **80 mJ** pulse energy and up to **2 W** average power

Up to **100 Hz** pulse repetition rate

Air cooled (**water-free**)

5 – 10 ns pulse duration

Smoothly variable pulse repetition rate for 1053 nm output wavelength models

> **2 G shot** lifetime of pump diodes

Built-in sync pulse generator for triggering of user equipment

Remote monitoring and control via built-in **Ethernet** interface

Optional **2 – 3 ns** pulse duration at up to **60 mJ** pulse energy (short cavity version)

Optional attachable attenuator for fundamental wavelength

Optional attachable pulse energy monitor

Optional attachable 2nd harmonic generator

Optional stand-alone 2nd, 3rd, 4th or 5th harmonic generator

APPLICATIONS

Light Induced Breakdown Spectroscopy (LIBS)

Light Detection And Ranging (LIDAR)

LCD repair

Laser ablation/cleaning

Time-of-Flight Spectroscopy (TOFS)

Light Induced Fluorescence (LIF) Spectroscopy

Flash photolysis

Pulsed Light Deposition (PLD)



Q2 series diode pumped, fully air-cooled, Q-switched laser designed for wide range of applications that require high peak power pulses.

Our innovative water-free laser crystal end-pumping technology allows to produce Gaussian-like, low divergence laser beam. At the same time, Q2 is versatile platform that can be configured in many ways.

It can be configured for 80 mJ pulse energy at 10 Hz pulse repetition rate. For high repetition rate configuration laser can produce up to 20 mJ at 100 Hz.

The laser can configured to emit 1053 nm or 1064 nm wavelength from Nd:YLF or Nd:YAG laser crystals respectively. Due athermal properties of Nd:YLF crystal, at 1053 nm the laser can operate from single shot to maximum pulse repetition rate without changes in beam divergence or profile.

In short cavity configuration pulse duration can be reduced by 50% in comparison to standard configuration. Peak power of pulse can reach more than 30 MW at pulse energy up to 60 mJ.

Thermo-electric cooler based temperature control system eliminate risks associated with water cooling (leaks, organic contamination etc.) and reduce maintenance costs. If requested, standard fan-cooled heatsink can be detached from the laser body and laser can be mounted on user-supplied cold plate or other cooling system.



Innovative laser design resulted in compact, user-friendly turnkey system that requires little maintenance. There is no chillers or bulky power supplies that one needs fit under the table. All laser electronics is integrated into Q2 housing and the only external modules are lightweight controller box that provides laser control interfaces and mains adapter that provides 12 or 28 VDC, 30 – 100 W powering (depending on model).

Laser is controlled through Ethernet port via build-in web-server. There is no need to install control software – any computer or even cell phone with modern web-browser will be able to control Q2. API is also provided for integration with user devices.

Low jitter triggering pulses for user equipment are available with up to 300 µs lead in internal triggering mode. In external triggering mode, laser pulsing can be externally triggered from delay generator.

Laser functionality can be further extended by wide range of auxiliary equipment:

- Second harmonic output can be produced from our attachable 2nd harmonic generator, model SHG.
- Up to fifth harmonic output can be produced from our stand-alone H-SMART series harmonic generators.
- Pulse energy can be adjusted with our motorized attenuator for fundamental wavelength beam.
- Pulse energy can be monitored by our attachable pulse energy monitor with analog and/or digital output.

SPECIFICATIONS AT 10 Hz PULSE REPETITION RATE ¹⁾

MODEL	Q2				
	-B10	-C10	-D10	-E10	-F10
Wavelength	1053 or 1064 nm				1053 nm
Pulse repetition rate ²⁾	10 Hz				
Pulse energy	10 mJ	15 mJ	35 mJ	60 mJ	80 mJ
Typical pulse duration ³⁾	< 8 ns		< 7 ns		< 5 ns
Pulse energy stability ⁴⁾	< 0.5 % RMS				
Power drift ⁵⁾	± 3.0 %				
Beam profile	bell-shaped, >80% fit to Gaussian				
Beam divergence ⁶⁾	< 1 mrad				
Polarization	linear, horizontal				
Typical beam diameter ⁷⁾	1.5 mm	2.0 mm	3.0 mm	4.0 mm	
Jitter ⁸⁾	< 0.5 ns RMS				

OPTIONAL HARMONICS GENERATOR ⁹⁾

Pulse energy	-B10	-C10	-D10	-E10	-F10
526.5 / 532 nm	4 mJ	7 mJ	15 mJ	30 mJ	40 mJ
351 / 355 nm	2.4 mJ	4.5 mJ	9 mJ	18 mJ	24 mJ
263 / 266 nm	1.2 mJ	2.5 mJ	5 mJ	10 mJ	12 mJ
211 / 213 nm	0.4 mJ	1 mJ	2 mJ	4 mJ	5 mJ

OPTIONAL ATTENUATOR ¹⁰⁾

Transmission range	0.5 – 95 %
--------------------	------------

DIMENSIONS

Laser head (W×L×H)	160 × 230 × 141 mm ³
Controller unit (W×L×H)	108 × 191 × 59 mm ³
Power adapter (W×L×H) ¹¹⁾	80 × 120 × 60 mm ³ typical

OPERATING REQUIREMENTS

Cooling requirements	air cooled
Ambient temperature	15 – 30 °C
Relative humidity	10 – 80 % (non-condensing)
Mains voltage	90 – 230 VAC, single phase, 47 – 63 Hz ¹²⁾
Average power consumption	30 W 40 W 50 W 60 W

¹⁾ Due to continuous improvements all specifications are subject to change. Unless stated otherwise all specifications are measured at fundamental wavelength and maximum pulse repetition rate. The parameters marked typical are not specifications. They are indications of typical performance and will vary with each unit we manufacture.

²⁾ Factory-set pulse repetition rate is fixed at max repetition rate shown in the table.

³⁾ At FWHM level at fundamental wavelength, measured with 350 ps rise time photodiode. Short pulse duration version is available, with pulse duration shorter by approx 50%. Inquire for detailed specifications.

⁴⁾ Measured during 30 seconds operation after warm-up.

⁵⁾ Over 8 hour period after 20 minutes of warm-up when ambient temperature variation is less than ±2 °C.

⁶⁾ Full angle measured at the 4σ level.

⁷⁾ Beam diameter is measured 20 cm from laser output at the 4σ level.

⁸⁾ In respect to falling edge of pump diode triggering pulse.

⁹⁾ Q2 is compatible with our attachable second harmonic generator (model SHG) and all models of stand-alone H-SMART harmonics generator. Pulse energies presented here are maximum values. Please refer to harmonic generator datasheets for detailed specifications.

¹⁰⁾ Motorized attenuator intended to be attached to the laser housing. Transmission can be changed remotely through laser web-server control interface.

¹¹⁾ Power adapter dimensions might differ from indicated here, depending on model.

¹²⁾ Laser can be powered from appropriate 12 or 28 VDC power source. Please inquire for details.

Laser controller unit



SPECIFICATIONS AT 20 / 50 Hz PULSE REPETITION RATE ¹⁾

MODEL	Q2						
	-B20	-C20	-D20	-E20	-B50	-C50	-D50
Wavelength	1053 or 1064 nm						1064 nm
Pulse repetition rate ²⁾	20 Hz				50 Hz		
Pulse energy	10 mJ	20 mJ	40 mJ ³⁾	65 mJ ⁴⁾	10 mJ	20 mJ	40 mJ
Typical pulse duration ⁵⁾	< 7 ns		< 5 ns		< 7 ns	< 6 ns	< 5 ns
Pulse energy stability ⁶⁾	< 0.5 % RMS						
Power drift ⁷⁾	± 3.0 %						
Beam profile	bell-shaped, >80% fit to Gaussian						
Beam divergence ⁸⁾	<1 mrad						
Polarization	linear, horizontal						
Typical beam diameter ⁹⁾	1.5 mm		3.0 mm	4.0 mm	1.5 mm	2.5 mm	3.5 mm
Jitter ¹⁰⁾	< 0.5 ns RMS						

OPTIONAL HARMONICS GENERATOR ¹¹⁾

Pulse energy	-B20	-C20	-D20	-E20	-B50	-C50	-D50
526.5 / 532 nm	5 mJ	10 mJ	25 mJ	35 mJ	5 mJ	10 mJ	20 mJ
351 / 355 nm	3 mJ	6 mJ	15 mJ	20 mJ	3 mJ	6 mJ	12 mJ
263 / 266 nm	1.5 mJ	3 mJ	7.5 mJ	10 mJ	1.5 mJ	3 mJ	6 mJ
211 / 213 nm	0.5 mJ	1 mJ	2 mJ	3 mJ	0.5 mJ	1 mJ	2 mJ

OPTIONAL ATTENUATOR ¹²⁾

Transmission range	-B20	-C20	-D20	-E20	-B50	-C50	-D50
	0.5 – 95 %				1 – 95 %		

DIMENSIONS

Laser head (W×L×H)	160 × 230 × 141 mm ³
Controller unit (W×L×H)	108 × 191 × 59 mm ³
Power adapter (W×L×H) ¹³⁾	80 × 120 × 60 mm ³ typical

OPERATING REQUIREMENTS

Cooling requirements	air cooled
Ambient temperature	15 – 30 °C
Relative humidity	10 – 80 % (non-condensing)
Mains voltage	90 – 230 VAC, single phase, 47 – 63 Hz ¹⁴⁾
Average power consumption	30 W 40 W 70 W 80 W 50 W 80 W 100 W



¹⁾ Due to continuous improvements all specifications are subject to change. Unless stated otherwise all specifications are measured at fundamental wavelength and maximum pulse repetition rate. The parameters marked typical are not specifications. They are indications of typical performance and will vary with each unit we manufacture.

²⁾ Factory-set pulse repetition rate is fixed at max repetition rate shown in the table.

³⁾ Pulse energy 40 mJ for 1053 nm and 35 mJ for 1064 nm.

⁴⁾ Pulse energy 65 mJ for 1053 nm and 60 mJ for 1064 nm.

⁵⁾ At FWHM level at fundamental wavelength, measured with 350 ps rise time photodiode. Short pulse duration version is available, with pulse duration shorter by approx 50%. Inquire for detailed specifications.

⁶⁾ Measured during 30 seconds operation after warm-up.

⁷⁾ Over 8 hour period after 20 minutes of warm-up when ambient temperature variation is less than ±2 °C.

⁸⁾ Full angle measured at the 4σ level.

⁹⁾ Beam diameter is measured 20 cm from laser output at the 4σ level.

¹⁰⁾ In respect to falling edge of pump diode triggering pulse.

¹¹⁾ Q2 is compatible with our attachable second harmonic generator (model SHG) and all models of stand-alone H-SMART harmonics generator. Pulse energies presented here are maximum values. Please refer to harmonic generator datasheets for detailed specifications.

¹²⁾ Motorized attenuator intended to be attached to the laser housing. Transmission can be changed remotely through laser web-server control interface.

¹³⁾ Power adapter dimensions might differ from indicated here, depending on model.

¹⁴⁾ Laser can be powered from appropriate 12 or 28 VDC power source. Please inquire for details.

DRAWINGS

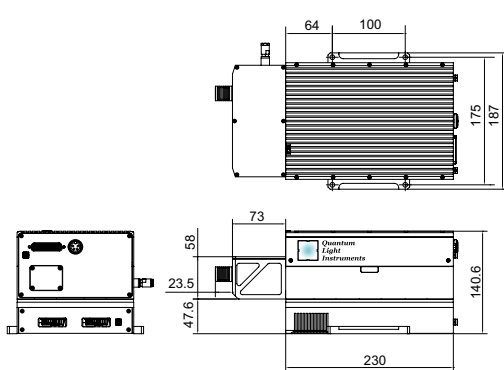

Q2 laser head with SHG module dimensions (in mm)

SPECIFICATIONS AT 100 / 200 Hz PULSE REPETITION RATE ¹⁾

MODEL	Q2				
	-200	-100	-A100	-B100	-C100
Wavelength	1064 nm				
Pulse repetition rate ²⁾	200 Hz		100 Hz		
Pulse energy	1 mJ	2.5 mJ	5 mJ	10 mJ	20 mJ
Typical pulse duration ³⁾	< 10 ns		< 8 ns		< 7 ns
Pulse energy stability ⁴⁾	< 0.5 % RMS				
Power drift ⁵⁾	± 3.0 %				
Beam profile	bell-shaped, >80% fit to Gaussian				
Beam divergence ⁶⁾	<2 mrad		<1.5 mrad		<1 mrad
Polarization	linear, horizontal				
Typical beam diameter ⁷⁾	1.5 mm		2.0 mm	2.5 mm	3.5 mm
Jitter ⁸⁾	< 0.5 ns RMS				

OPTIONAL HARMONICS GENERATOR ⁹⁾

Pulse energy	-200	-100	-A100	-B100	-C100
532 nm	0.5 mJ	1.25 mJ	2.5 mJ	5 mJ	10 mJ
355 nm	0.25 mJ	0.7 mJ	1.5 mJ	3 mJ	6 mJ
266 nm	0.1 mJ	0.3 mJ	0.7 mJ	1.5 mJ	3 mJ
213 nm	0.02 mJ	0.1 mJ	0.25 mJ	0.5 mJ	1 mJ

OPTIONAL ATTENUATOR ¹⁰⁾

Transmission range	1 – 95 %				
--------------------	----------	--	--	--	--

DIMENSIONS

Laser head (W×L×H)	160 × 230 × 141 mm ³				
Controller unit (W×L×H)	108 × 191 × 59 mm ³				
Power adapter (W×L×H) ¹¹⁾	192 × 178 × 46 mm ³ typical (for +28 VDC output)				

OPERATING REQUIREMENTS

Cooling requirements	air cooled				
Ambient temperature	15 – 30 °C				
Relative humidity	10 – 80 % (non-condensing)				
Mains voltage	90 – 230 VAC, single phase, 47 – 63 Hz ¹²⁾				
Average power consumption	40 W	50 W	70 W	80 W	100 W

¹⁾ Due to continuous improvements all specifications are subject to change. Unless stated otherwise all specifications are measured at fundamental wavelength and maximum pulse repetition rate. The parameters marked typical are not specifications. They are indications of typical performance and will vary with each unit we manufacture.

²⁾ Factory-set pulse repetition rate is fixed at max repetition rate shown in the table.

³⁾ At FWHM level at fundamental wavelength, measured with 350 ps rise time photodiode. Short pulse duration version is available, with pulse duration shorter by approx 50%. Inquire for detailed specifications.

⁴⁾ Measured during 30 seconds operation after warm-up.

⁵⁾ Over 8 hour period after 20 minutes of warm-up when ambient temperature variation is less than ±2 °C.

⁶⁾ Full angle measured at the 4σ level.

⁷⁾ Beam diameter is measured 20 cm from laser output at the 4σ level.

⁸⁾ In respect to falling edge of pump diode triggering pulse.

⁹⁾ Q2 is compatible with our attachable second harmonic generator (model SHG) and all models of stand-alone H-SMART harmonics generator. Pulse energies presented here are maximum values. Please refer to harmonic generator datasheets for detailed specifications.

¹⁰⁾ Motorized attenuator intended to be attached to the laser housing. Transmission can be changed remotely through laser web-server control interface.

¹¹⁾ Power adapter dimensions might differ from indicated here, depending on model.

¹²⁾ Laser can be powered from appropriate 12 or 28 VDC power source. Please inquire for details.

DRAWINGS

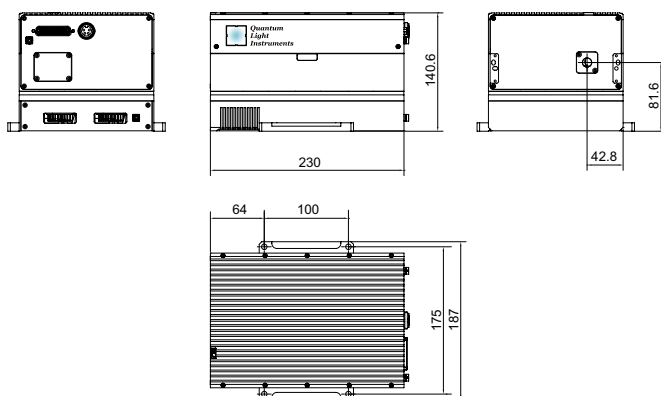

Q2 laser head dimensions (in mm)



AUXILIARY EQUIPMENT

Compatible with our attachable 2nd harmonic generator, model SHG.

Compatible with all our H-SMART series harmonic generators

Attachable motorized attenuator for fundamental wavelength beam.

Attachable pulse energy monitor with analog and/or digital output

上海昊量光电设备有限公司

中国区代理

官网: www.auniontech.com 电话: 185 0177 0670

邮箱: jiabin-wei@ahuniontech.com

地址: 上海市徐汇区漕宝路 86 号光大会展中心 F 座 3 楼

Quantum Light Instruments Ltd.

Mokslininku 6A

LT-08412, Vilnius, Lithuania