

HYPERION

The Hyperion colorimeter offers a unique combination of high speed and accurate colour measurement capabilities packed in a robust package. In comparison to its predecessors, the Hyperion has a significant improvement on filter characteristics and an incredible speed upgrade.

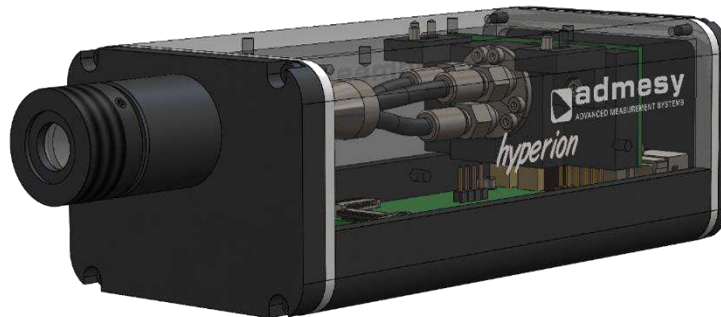

The Hyperion colorimeter is available with a several different optics ranging from 10mm spot size to 20mm. A fiber version is also available with several optics, custom optics can be applied on request. Added to the improved filter characteristics the high sensitivity, ultra-low noise electronics and a huge dynamic range make it the ideal device for display measurements especially at low levels.

HIGHLIGHTS

- Highly accurate colour measurement according to human eye (CIE1931)
- Fast colour measurement even at low luminance level
- Flicker luminance (Y) function: 2000 samples/second
- Auto-range function
- Powerful MCU enables internal JEITA flicker calculation
- Mechanical shutter
- USBMTC standard compliant
- Windows, Linux and MAC OSX compatible
- Directly supported in Labview, LabWindows, Visual Studio via VISA library

STANDARDS

The Hyperion is compliant to the USBMTC standard and can be used in combination with external provided USBMTC compliant drivers. Currently it has been tested on Windows, Linux and Apple OSX using NI VISA (www.ni.com/visa) and using the open source drivers on Linux (i686, x86_64 and ARM).

GENERAL SPECIFICATIONS

Interfaces	
USB 2.0	USBMTC compliant, SCPI command set, high speed device
RS 232	For PC and embedded purposes, using same command set as USB
Trigger in & out	5V compliant

Power ratings				
	Min voltage	Typical voltage	Max voltage	Max current
USB power	4.75V	5.00V	5.25V	300mA
9V power	8.75V	9.00V	9.25V	300mA

Measurement system	
Photo detector	3 silicon photo diode using XYZ interference filter
Spectral response	Approximates CIE 1931 colour matching functions
Measurement parameters	XYZ, Yxy, Yuv, correlated colour temperature (CCT), dominant wavelength DWL, Flicker, Response time
Size (HxWxD)	53x70x147 mm (without lens system)
Weight	670 gram
Mounting	12 M3 thread holes spread over four sides

TYPICAL SPECTRAL SENSITIVITY

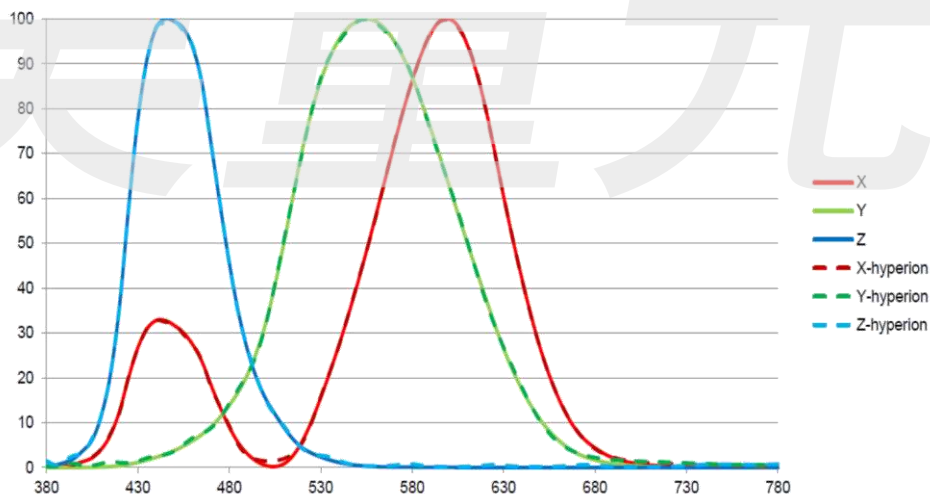

2.1 MM FOCUSED MEASUREMENT SPECIFICATIONS

Measurement system	
Optical system- focusing lens	Acceptance angle 20° (± 10)
Measurement spot size	2.1 mm at 41.9 mm working distance (front side lens system)
Working distance	41.9mm +/-2mm
Flicker measurement speed (sample mode)	Luminance 2000 samples / second, XYZ 2000 samples / second Correct detected frequency of at least 1 Hz.
Colour measurement speed	Colour 22 ms or higher, depending on luminance level and frame frequency

Sample mode signal frequency response	
Parameter	F _{3db} ^a
Gain 1	DC – 500 Hz
Gain 2	DC – 500 Hz
Gain 3	DC – 500 Hz

General	
Operating temperature	10-35°C ²
Shutter lifetime	> 1000000 h
Shutter speed	250 - 300 ms depending on temperature and lifetime

TUBES

Standard tubes are available for easy alignment, contact Admesy for details.



Specifications		Auto-range condition 1		Auto-range condition 2			
	Performance guarantee range	0.003 to 12000 Cd/m ²					
Luminance		Spec	Max int time [μs]	Spec	Max int time [μs]		
	Accuracy(white)	~ 0.003 cd/m ²	+/-9%	1000000	—		
		~ 0.01 cd/m ²	+/-5%	1000000			
		~ 0.1 cd/m ²	+/-3%	100000			
		~ 1 cd/m ²	+/-1.5%	33333			
		~ 10 cd/m ²					
		100 ~ cd/m ²					
	Repeatability auto-range on (2σ) *1	~ 0.003 cd/m ²	4%	1000000	4%	1000000	
		~ 0.01 cd/m ²	1%	1000000	4%	250000	
		~ 0.1 cd/m ²	1%	100000	2%	50000	
		~ 1 cd/m ²	0.2%	33333	0.2%	33333	
		~ 10 cd/m ²					
~ 100 cd/m ²							
Chromaticity	Performance guarantee range	0.01 to 4000 Cd/m ²					
	Accuracy (white)	~ 0.01 cd/m ²	+/- 0.006	1000000	—		
		~ 0.1 cd/m ²	+/- 0.002	1000000			
		~ 1 cd/m ²	+/- 0.0015	33333			
		~ 10 cd/m ²					
		~ 100 cd/m ²					
	Repeatability auto-range on (2σ) *1	~ 0.01 cd/m ²	0.0025	1000000	0.0025	1000000	
		~ 0.1 cd/m ²	0.0003	1000000	0.0025	100000	
		~ 1 cd/m ²	0.0003	100000	0.0004	33333	
		~ 10 cd/m ²	0.0002	33333	0.0002	33333	
		~ 100 cd/m ²					
	Flicker Wave-form	Sampling frequency	2000				
Memory for saving sampling data		30000 samples					
Max measurement time		15 seconds					
Dynamic range - luminance		1 - 12000					
Dynamic range - frequency		0.5 - 250					
Synchronization mode		ARFREQ					
Object under measurement (frequency)		0.5 - 250					

1 Measured with internal Admesy reference display.

HYPERION 2.1 MM FOCUSED DIMENSIONS

