

DR-VE-10-MO

Preliminary specification

The DR-VE-10-MO is a non-inverting VERSatile RF amplifier module designed for analog, pulse and digital applications up to 12 GHz.

The following table is a summary of both specifications and measurements. All specifications given at 25°C.

Parameter	Symbol	Unit	Min	Typ	Max	Conditions
Impedance	Z_0	Ohm	-	50		-
Low Frequency 3dB Point	f_{LOW}	KHz	-	16	25	-
High Frequency 3dB Point	f_{HIGH}	GHZ	11	12	-	-
Small Signal Gain	S_{21}	dB	28	30	-	-
Gain ripple	-	dB	-	-	± 1.5	$f < 12$ GHz
Input Return Loss	S_{11}	dB	-	-	-10	$f < 20$ GHz
Output Return Loss	S_{22}	dB	-	-	-10	$f < 19$ GHz
Isolation	S_{12}	dB	-	-	-60	$f < 20$ GHz
ANALOG MODE						
Output Power 1 dB Compression	P_{1dB}	dBm	-	21 19	-	0 - 10 GHz 10 - 16 GHz
Saturated Output Power	P_{sat}	dBm	-	-	23	$F < 10$ GHz, $V_{in} \sim 0.6 V_{pp}$
Input power	P_{in}	dBm	-	-	0	-
Noise Figure	NF	dB	2	-	4	2 - 10 GHz
Delay Time	t_d		-	450	-	-
PULSE MODE						
Pulse Width	PW	s	70 p	-	300 n	-
Pulse Repetition Frequency	PRF	Hz	10	-	1 G	Depending on duty cycle
Input Pulse Amplitude	V_{in}	V_{pp}	-	0.18	0.35	Square pulse
			-	-	0.12	Pulse shaping
Rise / Fall Time	t_r/t_f	ps	-	24/24	28/28	20%...80%
Output Pulse Amplitude (user adjustable)	V_{out}	V_{pp}	-	-	8	$V_{in} \sim 0.2 V_{pp}$
DIGITAL MODE						
Data Rate	-	Gb/s	0.1	-	14	-



Input Eye Amplitude	V_{in}	V_{pp}	-	0.2	1	-
Output Eye Amplitude (user adjustable)	V_{out}	V_{pp}	2.5	6	8	$V_{in} \sim 0.2 V_{pp}$
Saturated Output Eye Amplitude	V_{outsAT}	V_{pp}	-	-	8.5	$V_{in} \sim 0.25 V_{pp}$
Eye Cross point (user adjustable)	X_p	%	45	50	55	-
Output Jitter, RMS value	J_{RMS}	ps	-	0.9	0.95	calculated value; see note below
Rise Time / Fall Time	t_r/t_f	ps	-	20/20	22/22	20%...80%
Q Factor	Q	-	25	30	-	$V_{out} \sim 6 V_{pp}$
POWER SUPPLY						
Driver Supply Voltage	V_{bias}	V	-	+12	+12	-
Driver Supply Current	I_{bias}	mA	-	-	450	-
OTHERS						
Input Connector	SMA Female					
Output Connector	SMA Male					
Dimensions	-	mm	40 x 54 x 12.7			Excluding connectors
Storage Temperature	T_{st}	°C	-20	-	70	-
Operating Temperature	T_{op}	°C	0	25	40	-
Power Dissipation	P_{diss}	W	-	3.6	5.4	-



Mechanical Diagram and Pinout

All measurements in mm

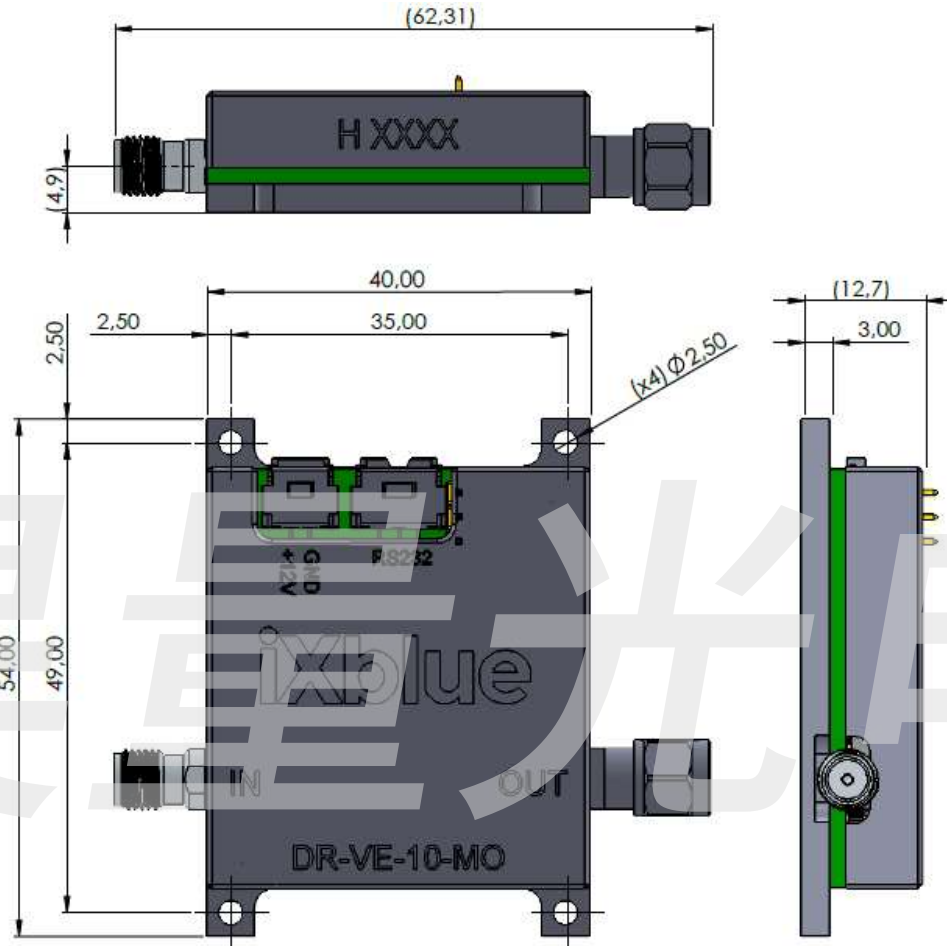

Mechanical Diagram and Pinout with HS-MO5

All measurements in mm

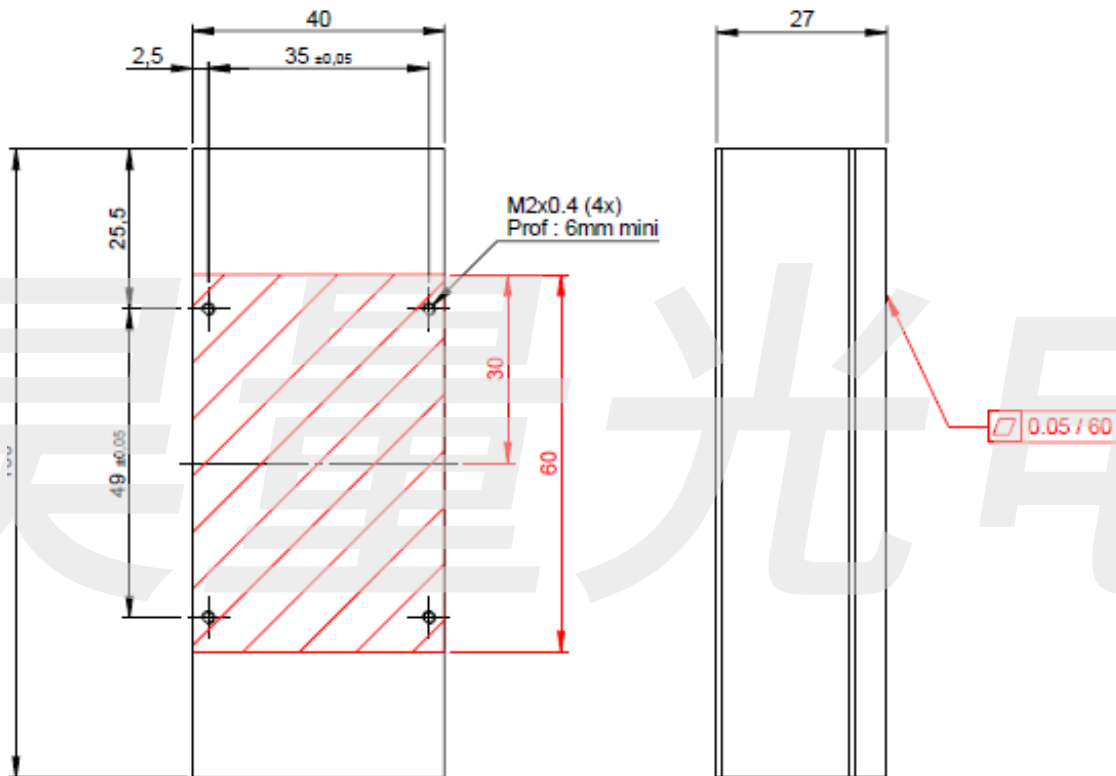
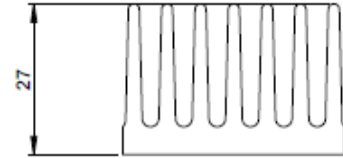

Typical Output Response:

S-parameters and P_{1dB} measurement:

Test conditions: Output Amplitude = 70, Gain = 40, Crosspoint = 60, 12 V, 300 mA

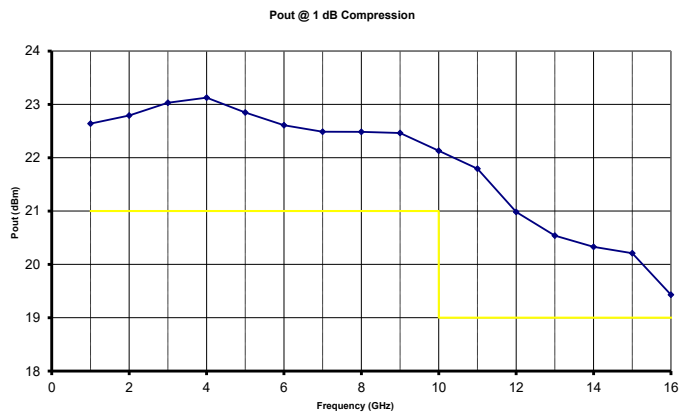
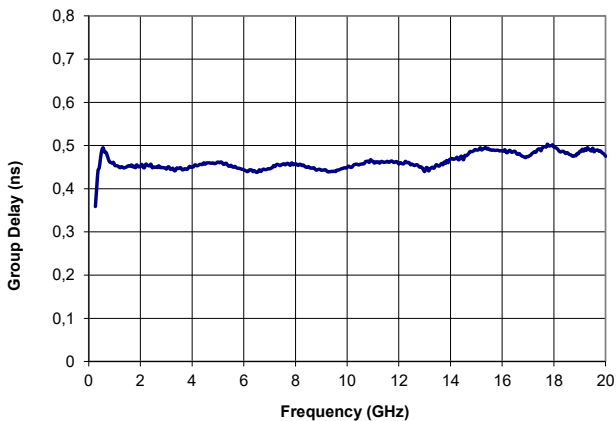
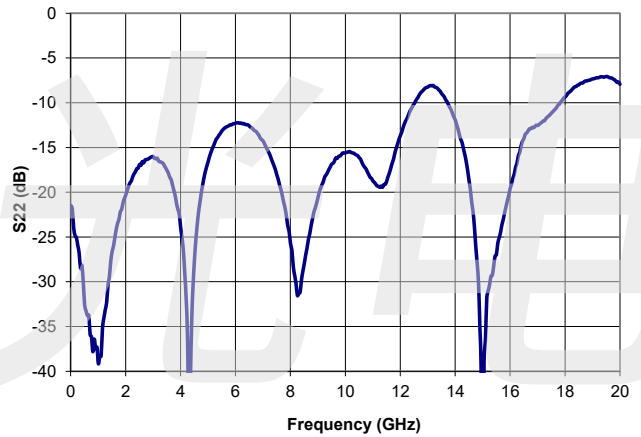
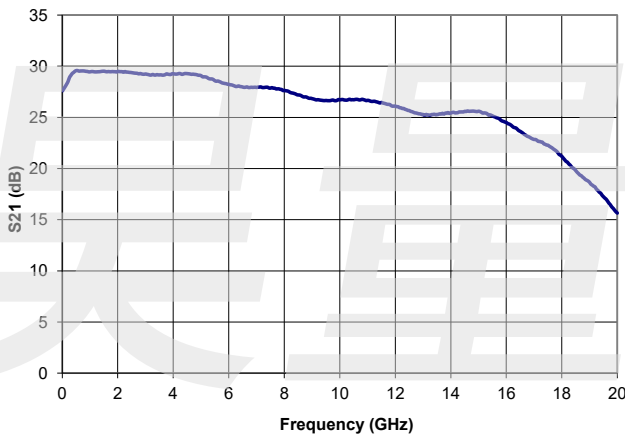
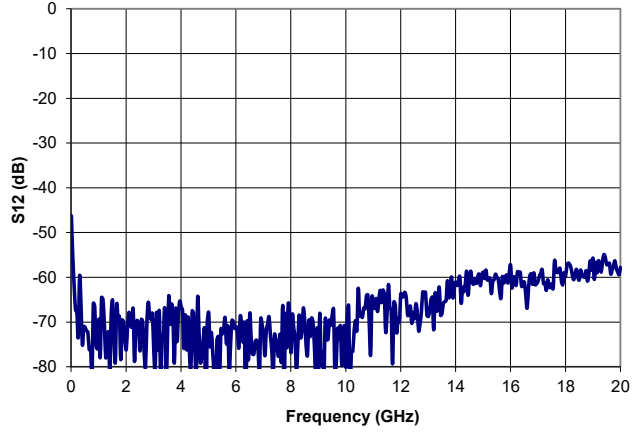
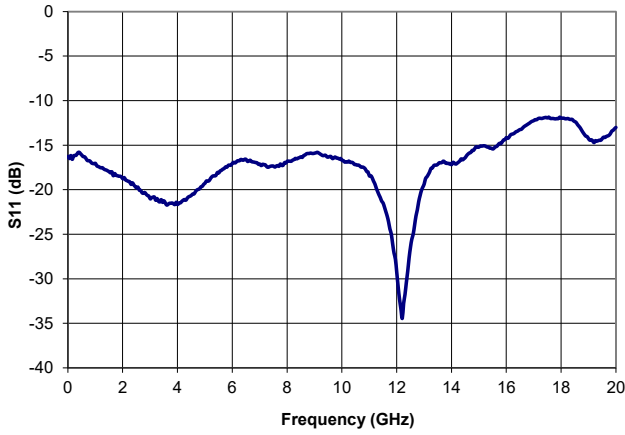

Pulse measurement (Pulse mode, square pulse, $0.18 V_{pp} < V_{in} < 0.35 V_{pp}$):

Test conditions: Depends on Pulse sign (\square or \square)





Linear operation (Pulse mode, Pulse shaping, $V_{IN} < 0.12 V_{pp}$):



Digital measurement:

Test conditions: Output Amplitude = 45, Gain = 30, Crosspoint = 55.
12V, 280mA

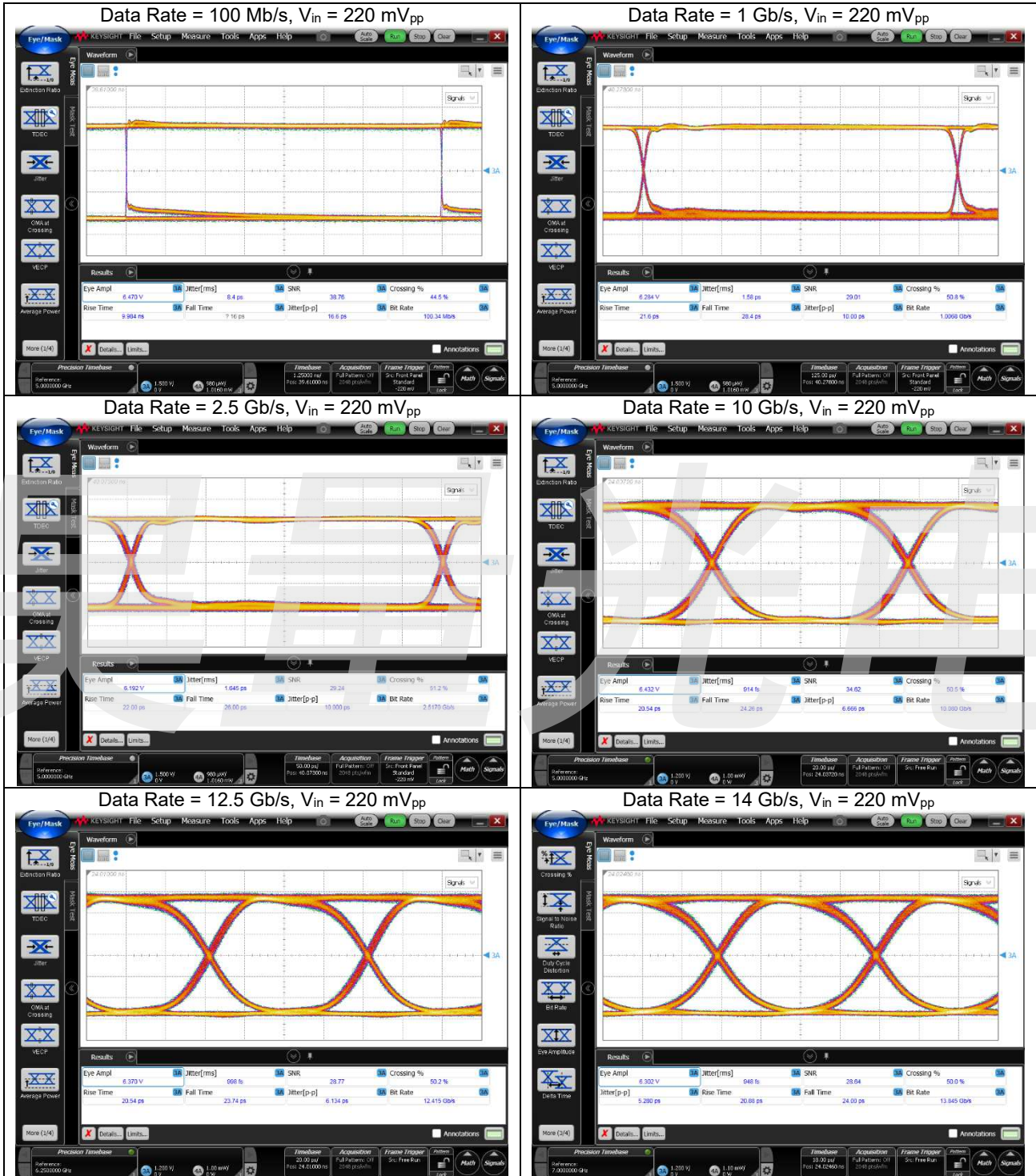

Driver Control Application:

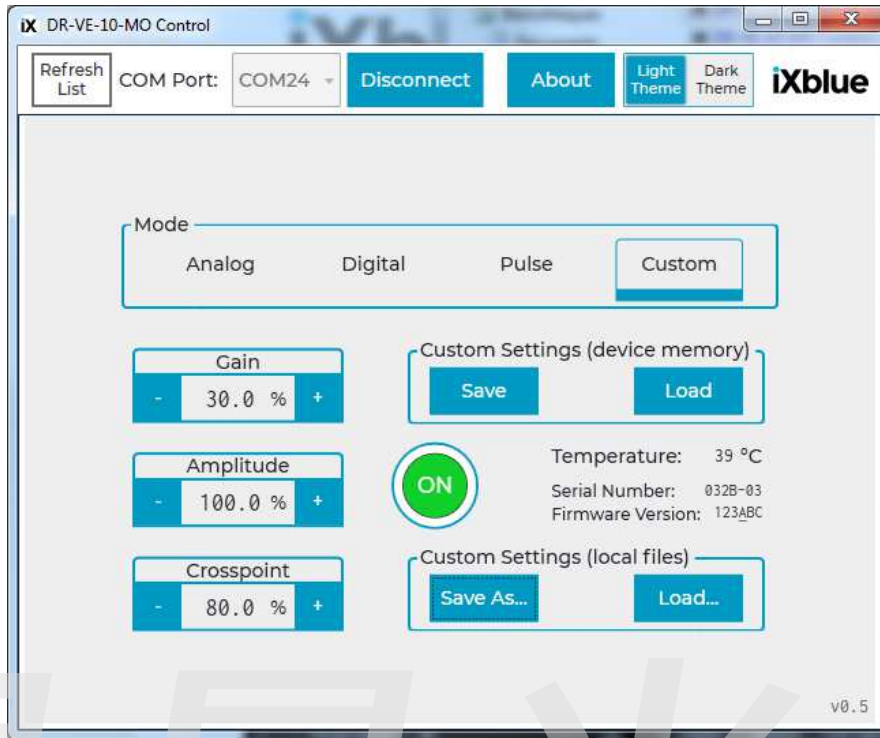

昊量光电

02-2021 / DR-VE-10-MO PRELIMINARY / SP-0227-PR-01

