

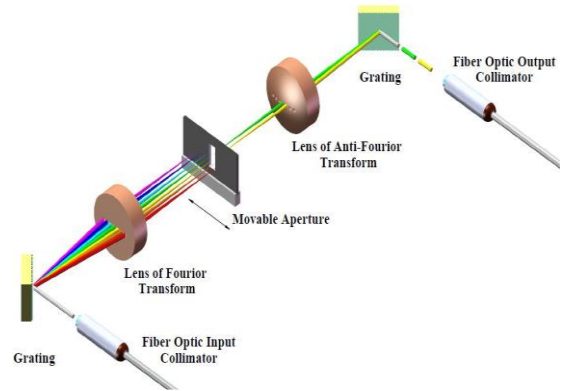

Bandwidth Variable Filters (Fat-Top)

Bandwidth Variable Filter of BWTF-series is built based on free-space optics combing with diffraction grating to produce a flat-top transmission. It is a 2-port fiber-optic device. When a wide-band spectrum is injected to the input port, the tunable filter will select a target band for output and reject the rest band of spectrum. Transmission bandwidth is variable at a centre wavelength fixed within some spectral range. Bandwidth adjustment is actuated by either a precise micrometer driver or a micro step-motor connected to a PC through a USB interface in which actuation is monitored by a built-in encoder and controlled dynamically in a closed-loop.



Operating Principle and Tuning Mechanism

Patent-pending optics design offers a great option of bandwidths and tuning ranges with unprecedented low insertion loss and polarization dependent loss (PDL) in the market. Precise tuning mechanism enables filters to provide high wavelength resolution and excellent wavelength-tuning repeatability. Both of manual and electric version filters are available over X-, O-, S-, C-, & L- bands.

Key Features

- Up to 100nm wavelength tuning range available over 1000-1700nm
- Unprecedented low insertion loss and PDL
- High optical power handling
- Accurate and uniform bandwidth over whole tuning range
- Down to 0.2nm FWHM bandwidth
- High out-band suppression

Applications

- ASE noise suppression
- DWDM channel filtering
- WDM wavelength tuning
- Pulse shaping

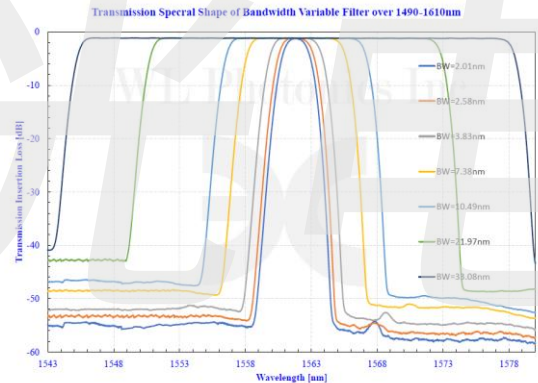

Spectral Shape of Bandwidth Variable Filter



Electric S- or P- Version Filter with RS232



Specifications of Bandwidth Variable Filter (BWTF-version-)

Center Wavelength	1060nm±30nm	1310nm±30nm	1550nm±30nm	1600nm±30nm
FWHM Bandwidth Variable Range ²	BW ¹ _{min} to 40nm	BW _{min} to 40nm	BW _{min} to 40nm	BW _{min} to 40nm
	BW _{min} =1.40nm for S-version	BW _{min} =2.00nm for S-version	BW _{min} =2.50nm for S-version	BW _{min} =2.50nm for S-version
	BW _{min} =0.60nm for P-version	BW _{min} =0.80nm for P-version	BW _{min} =1.00nm for P-version	BW _{min} =1.20nm for P-version
	BW _{min} =0.20nm for U-version	BW _{min} =0.25nm for U-version	BW _{min} =0.35nm for U-version	BW _{min} =0.4nm for U-version
Wavelength Resolution	0.05nm			
Wavelength Repeatability	±0.05nm			
Insertion Loss	2.0dB typ. and 3.0dB max. (Connector exclusive)			
Polarization-Dependent Loss	0.15dB typ./0.30dB max. over tuning range (SM fiber pigtail only)			
Extinction Ratio	20dB (PM fiber pigtail only without connector)			
Spectral Shape	Flat-top			
Passband Flatness	<0.05dB for BW < 2x BW _{min}			
Filter Edge Rolling-Off Slope ³	30dB/nm for S-version	25dB/nm for S-version	22dB/nm for S-version	20dB/nm for S-version
	80dB/nm For P-version	60dB/nm For P-version	55dB/nm For P-version	50dB/nm For P-version
	150dB/nm For U-version	120dB/nm For U-version	100dB/nm For U-version	100dB/nm For U-version
Max. Optical Power	500mW (CW). Up to 5.0W (CW) power handling available on request			
Return Loss	>45dB			
Out-Band Suppression	>50dB for BW < 2x BW _{min}			
Polarization Mode Dispersion	<0.2ps (SM fiber pigtail only)			
Group Delay	<0.1ps/nm			
Electric Interface ⁴	USB or RS 232			
Pigtail Fiber Type ⁵	HI1060	SMF-28e		
	Panda PM980	Panda PM1300	Panda PM1550	
Operating Temp	10°C to 50°C			
Storage Temp	-10°C to 75°C			
Dimension	See dimension drawings below			
Weight	<0.75kg typical			
Other	RoHS compliant			

Notes: ¹ BM_{min} is minimum accessible flat-top FWHM bandwidth. ² More than 40nm up to 100nm bandwidths available on request. ³ Measured from -3dB down to -43dB level. ⁴ Other interfaces available on request. ⁵ Aligned in PM slow axes (fast-axis blocking as standard). Other fibers such as LMA or PLMA available on request.



Dimensions of Electric Bandwidth Variable Filter (BWTF-ES- or EP-version)

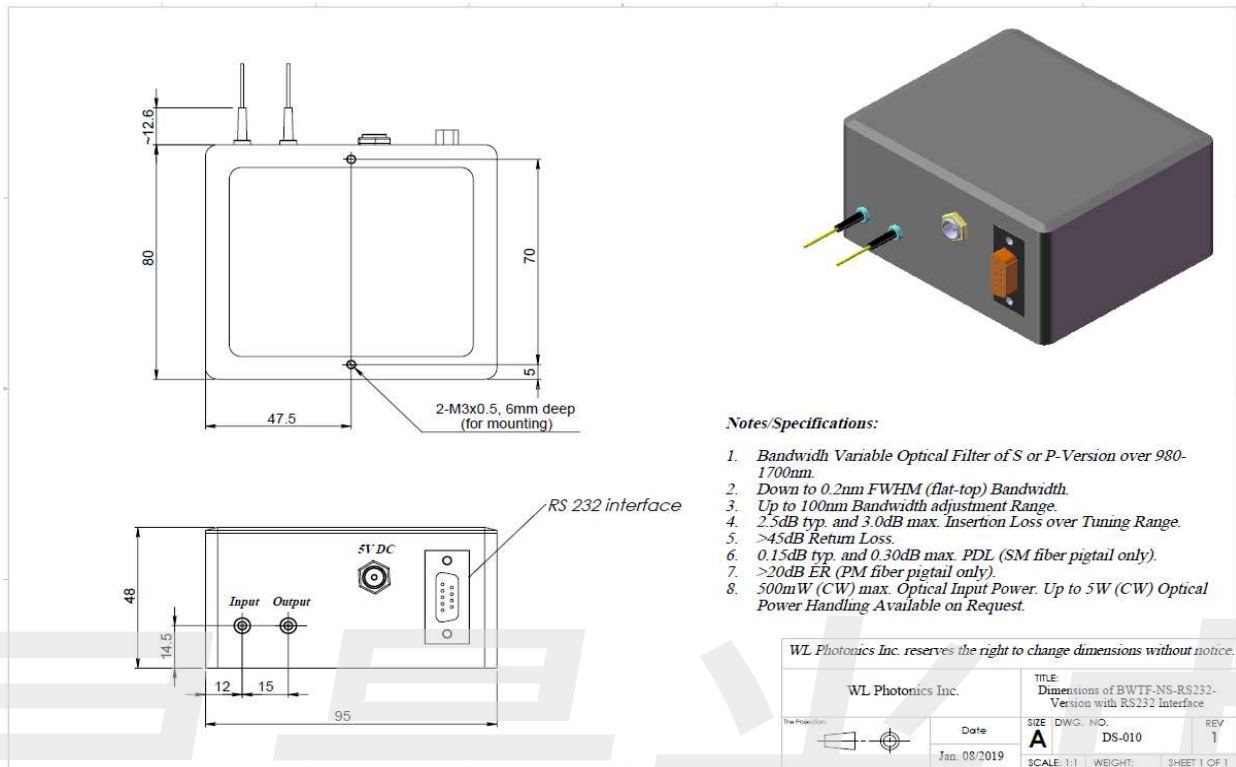

USB interface of electric tunable filters for Filter Bandwidth Tuning (FWT) through a PC is equipped with USB-RS232 virtual serial port interface (USB B-type connector). The power supply is provided from either USB directly or an extra 5V DC (on request). It is easy to use any Serial COM Port Software in PC to control FWT, such as HyperTerminal and Tera Term. The command set is very simple and easy to drive the filter to find the home position, go to desirable center wavelengths of transmission band or any indicated positions within actuation range.

Ordering Information

Part Number of Manual Version: BWTF-M **A**-**B**-**C**-**D/E**-**F**

Part Number of Electric Version: BWTF-E **A**-**B**-**C**-**D/E**-**F**-**G**

- A. Version type. **S**, **P**, or **U** is for S-, P- or U-version respectively.
- B. Center wavelength in nanometer: **1550** is for 1550nm center wavelength and **1310** is for 1310nm center wavelength.
- C. Fibre type: **SM** for single mode fiber and **PM** for Panda polarization maintaining fibre, or others such as LMA or PLMA.
- D. Pigtail cable diameter in millimeter: **0.25** is for 250µm OD buffer fibre, **0.9** is for 900µm OD loose tube and **3.0** is for 3.0mm OD cable (only existing for pigtail version).
- E. Pigtail length in meter: **0.5** is for 0.5m long and **1.0** is for 1M long (only existing for pigtail version).
- F. Connector type on pigtail end. such as **FC/APC**, **FC/UPC** **SC/APC** or **LU/UPC** and **00** is for no connector.
- G. Interface type. **USB** is for USB interface, **I²C** is for I²C interface and **SPI** is for SPI interface.



Example 1: BWTF-MP-1530-SM-3.0/1.0-FC/APC

Description: P-version fibre optic manual polarization-insensitive bandwidth variable filter centered at 1530nm with 1M long, 3.0mm OD loose cabled SMF-28e fibre pigtailed and FC/APC connectors on pigtail ends. Bandwidth variable from 1.0nm to 40nm FWHM (flat-top), 50dB/nm filter edge rolling-off slope and 500mW (CW) max. input optical power.

Example 2: BWTF-MU-1560-SM-FC/APC

Description: U-version fibre optic manual polarization-insensitive bandwidth variable filter centred at 1560nm with receptacle input/output for FC/APC connectors on pigtail ends and SMF-28e operating fiber. Bandwidth variable from 0.35nm to 40nm FWHM (flat-top), 100dB/nm filter edge rolling-off slope and 500mW (CW) max. input optical power.

Example 3: BWTF-EU-1310-PM-0.9/1.0-FC/UPC-USB-5.0

Description: U-version fibre optic electric polarization-sensitive bandwidth variable filter at 1310nm centered at 1310nm with 1.0M long, 0.9mm OD loose cabled Panda PM 1300 fiber pigtailed aligned in PM slow-axes (fast-axis blocking) and FC/UPC connectors on pigtail ends. Bandwidth variable from 0.25nm to 40nm FWHM (flat-top), 120dB/nm filter edge rolling-off slope, 5.0W (CW) max. input optical power and USB interface.

Customization

Besides the specifications above, other customizations in terms of operating band, transmission bandwidth, power handling, interface and foot print, or other type functionalities related to spectral manipulations are available, please ask our sales for solutions.