

POWERFUL LIGHTSOURCE TUNABLE FROM 250 TO 2500 NM

ArcTune

ArcTune is a compact, portable, easy to use, powerful and effective tunable lightsource.



ArcTune delivers spectral output of milliwatts of energy tunable in spectral range from 250 to 2500 nm with selected bandwidth.

ArcTune design is based on wide-aperture monochromator M150i or M266i and unique xenon 75W or 150W lightsource PowerArc™ by HORIBA Scientific.

FEATURES

- Optical power – dozens of milliwatts
- Spectral resolution up to 0,1 nm
- Ozone-free arc xenon lamp PowerArc™ with proprietary effective ellipsoidal reflector
- Automated monochromator at your option (M150i or M266i)
- Power density calculator in the selected spectral range (digital evaluation)
- Achromatic object glass for collimated output beam Optical
- Achromatic condenser for fiber launching

Lightsource PowerArc™ consists of the horizontal arc xenon lamp producing a continuous spectrum from 250 nm to 2500 nm and the proprietary on-axis ellipsoidal reflector.

At the heart of the PowerArc™ lamp housing is a proprietary on-axis ellipsoidal reflector. These reflectors collect up to 70% of the radiant energy from the arc lamp, versus only 12% for typical condenser systems in vertical lamp housings. The ellipse literally wraps around the arc lamp, collecting 5 to 6 times more output power than a conventional system.

PowerArc™ housing is sealed, without forced air cooling. There is no continuous ozone creation inside lamp housing, so the additional cooling for ozone removal is not required. 75W lamps do not require water cooling as well.

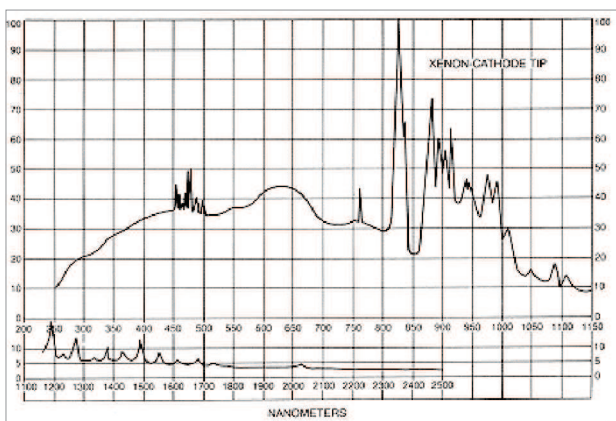

Continuous spectral output in range from 250 to 2500 nm produced by arc xenon lightsource PowerArc™.

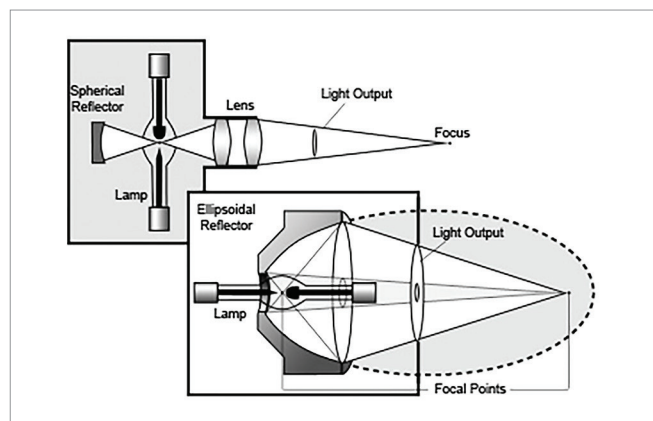

Unique ellipsoidal reflector in PowerArc™ collects 5 to 6 times more output power than a conventional system with spherical reflector.

Monochromator choice (compact M150i or multifunctional M266i) allows to optimize required optical power and spectral resolution of the ArcTune, as well as the automatization of the system. Both monochromators are used in Imaging modification, with astigmatism correction. Spectral specifications of ArcTune are dependent on the selected diffractive grating for specified spectral range.



Monochromator M150i - effective and compact, can be supplied with 1, 2 or 3 gratings. It has an option of slit selection: automated slits with slightly tunable width or a bundle of replaceable slits with fixed width for manual setting.



Monochromator M266i is fully automated, can contain up to 4 gratings; its focal length is twice of M150i. It allows to open the slit two times wider for specified bandwidth of spectral range, and thus optical power is 4 times larger.

ARCTUNE SPECIFICATION

Model	ArcTune - M150-75W	ArcTune - M150-150W	ArcTune - M266-75W	ArcTune - M266-150W
Xenon lightsource PowerArcTM	75 W	150 W	75 W	150 W
Ellipsoidal reflector	f / 4.5	f / 4.5	f / 4.5	f / 4.5
Spot size on entrance slit of the monochromator	5.4 mm	10.5 mm	5.4 mm	10.5 mm
Monochromator	M150i (Imaging)	M150i (Imaging)	M266i (Imaging)	M266i (Imaging)
Focal length of the monochromator	142 mm	142 mm	284 mm	284 mm
Output spot size	7.3 mm	10 mm	7.3 mm	12 mm
Output optical power	Dependent on Xe lamp, spectral range, monochromator and grating (Calculating mini-program provided)			

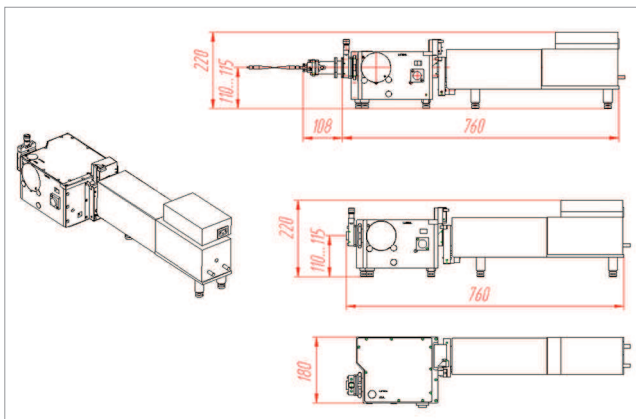

ArcTune-M150 external view and dimensions.

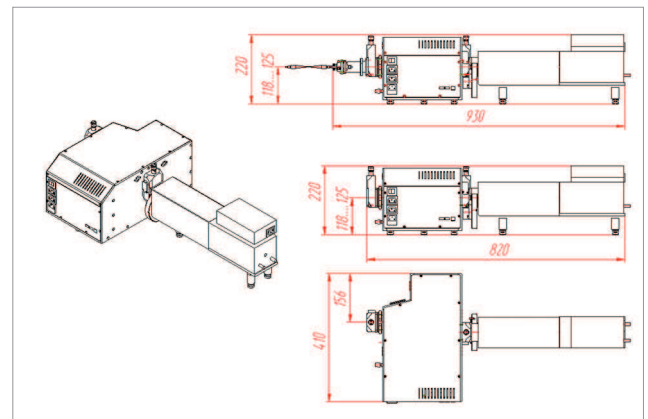

ArcTune-M266 external view and dimensions.