

FOC NANOPositionER

The FOC is a nanopositioner dedicated to accurate positioning of microscope objective. It is available with 100, 200, 300 or 500 microns of travel. The FOC is used in a wide range of applications: Z-stack, 3D imaging, autofocus or together with automated focus stabilisation devices, which we can also provide. It is made from aluminium, steel and brass, and is equipped with sensors offering stability in the picometer level.

The brass mounting ring can easily be changed so that every objective would fit in the FOC nanopositioner. Threads available are the RMS, M25, M26, M27 and M32.

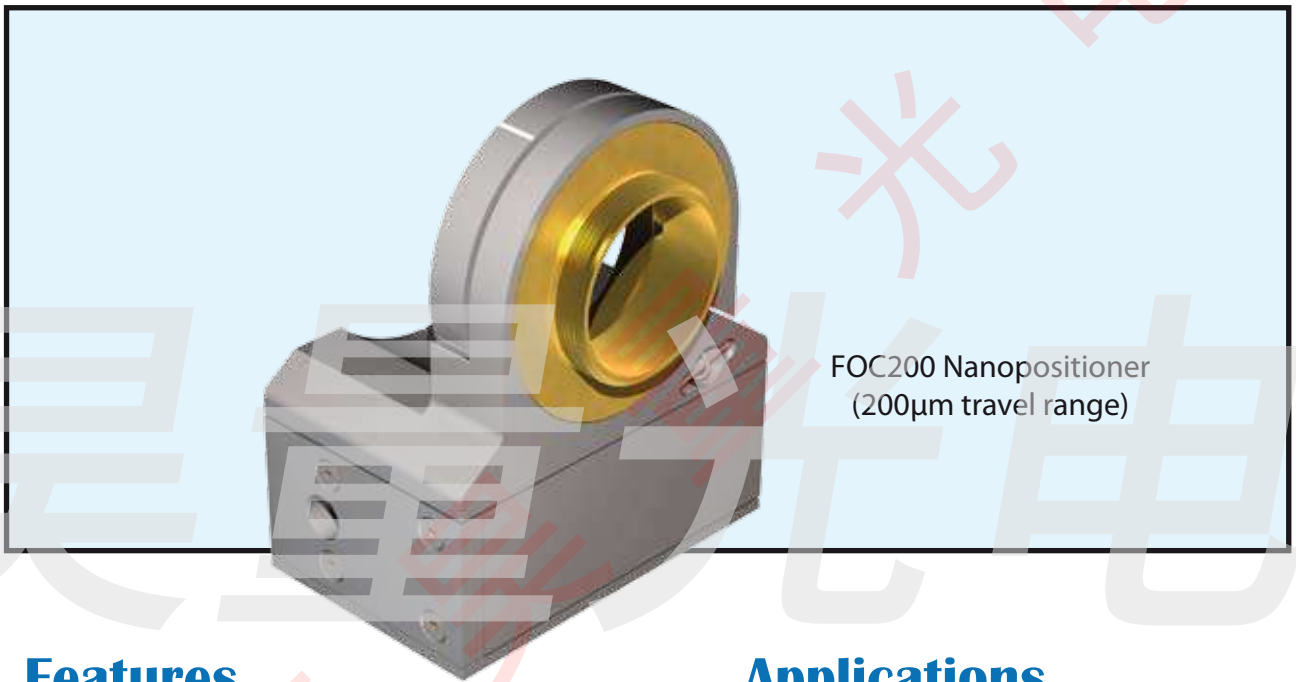

FOC200 Nanopositioner
(200 μ m travel range)

Features

- Travel range up to 500 μ m
- Moves objectives with sub-nm resolution
- Parallel flexure guiding
- Closed loop control
- Silicon sensor technology
- Less than 50pm noise floor

Applications

- Interferometry
- Autofocus system
- 3D imaging
- Confocal microscopy
- Super resolution microscopy
- Semiconductor metrology

Specifications

	FOC.100	FOC.200	FOC.300	FOC.500	Unit
Range of motion Z	100	200	300	500	μm
Resolution Z	0.1	0.2	0.3	0.5	nm
Typical noise floor Z	0.01	0.02	0.03	0.05	nm
Full range repeatability Z	0.2	0.4	0.6	1	nm
Linearization Z	0.02%	0.02%	0.02%	0.02%	(typical)
Resonant frequency Z	500	350	250	200	Hz
Stiffness Z	0.6	0.5	0.4	0.25	N/ μm
Maximum Load* :					
- horizontal use		1		1	kg
- vertical use		0.5		0.5	kg
Sensor		Silicon HR sensor		Silicon HR sensor	
Size W x L x H		53.6 x 64.2 x 34.5		59 x 63.3 x 41	mm
Material		Al/ SS / Brass		Al/ SS / Brass	
Cable length**		2		2	m
Controller		Standard		Standard	

*Higher load on request

**Higher length on request

Drawing

