

How to Configure a SWIR Microscope for Your Application



Top Ten Issues and Requirements to Consider and Define Before You Lock In Specifications

1. Range in Field of View
2. Spectral Range Requirement
3. Fixed or Range in Magnification
4. Working distance
5. Illumination Requirement
6. Sensor Selection
7. Software Options
8. Microscope Stand Options
9. Sample Mounting and Control
10. Additional Considerations



1. Specify the Range in Field of View That You Need for your application

You need to specify the range in field of view that will be needed as the choice of microscope objective lens and all other components in the optical train will flow from this requirement.

Examples of range in FOV are:

- 1) 0.1 mm X 0.1 mm to 0.4 mm X 0.5 mm
- 2) 0.3 mm X 0.2 mm to 0.8 mm X 0.7 mm

Once your microscope is assembled you can change FOV range easily, usually by changing the objective lens. This can be accomplished in a matter of seconds.

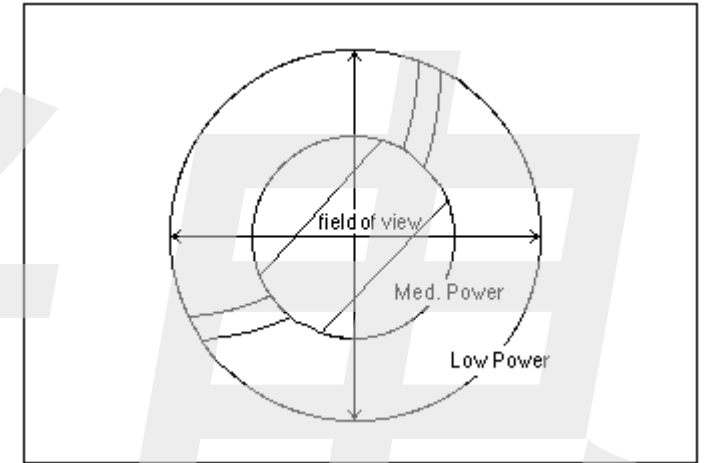

Anatomy of an Example SWIR Microscope

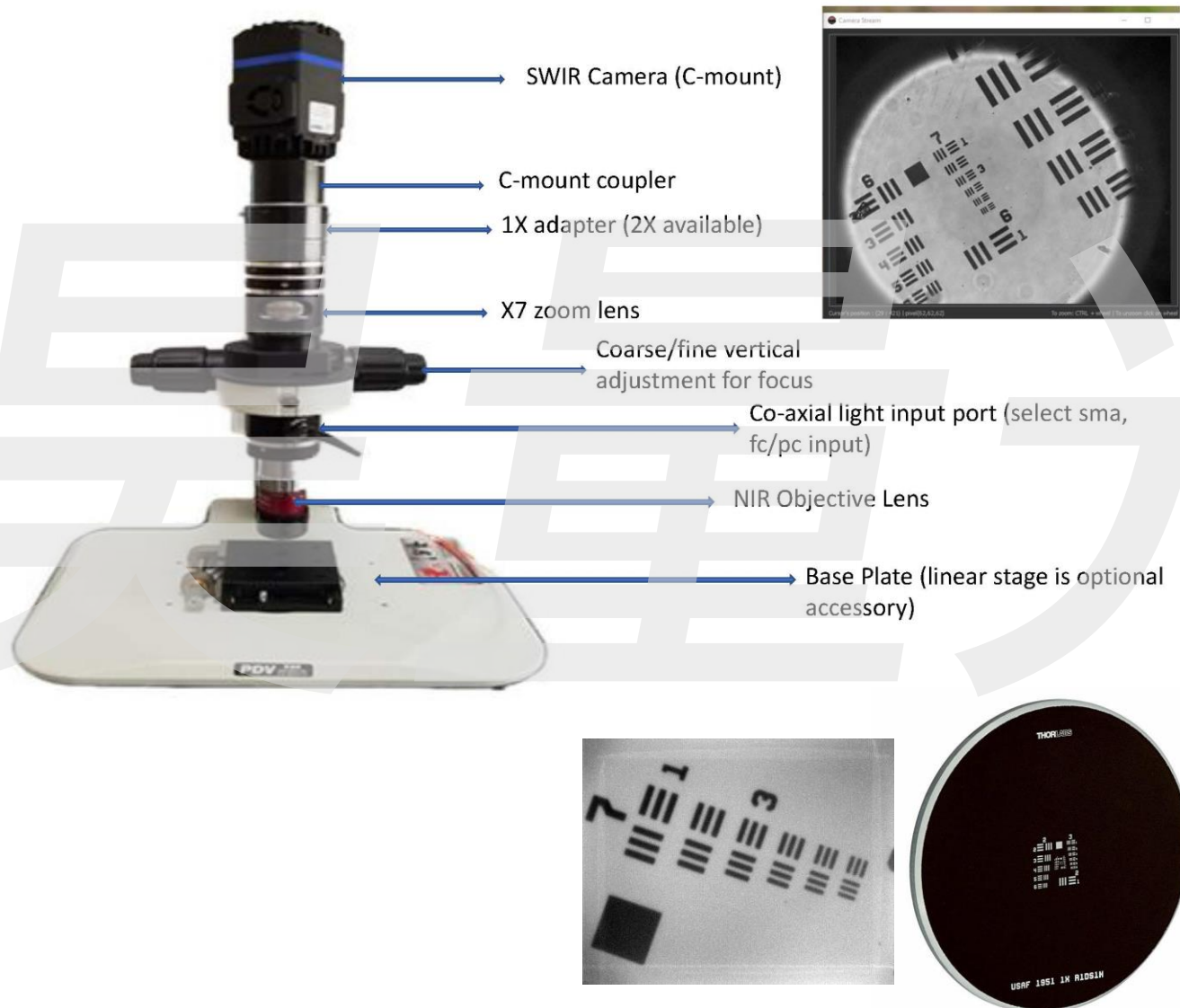

This microscope is configured with an X2 NIR optimized objective lens, zoom lens which will support of swing in magnification of X12, an attachment which will double the collective magnification of the objective lens and zoom lens. The magnified image is detected by a SWIR VGA camera which has a pixel format of 640X512 and pixel size of 15 μm . To achieve focus the microscope optics are mounted properly on a stand which supports both fine and coarse vertical adjustment. The resolution of the microscope is checked with a standard calibrated microscope target where the spatial distances of the features are known.

SWIR Microscope Mounted on Optical Breadboard

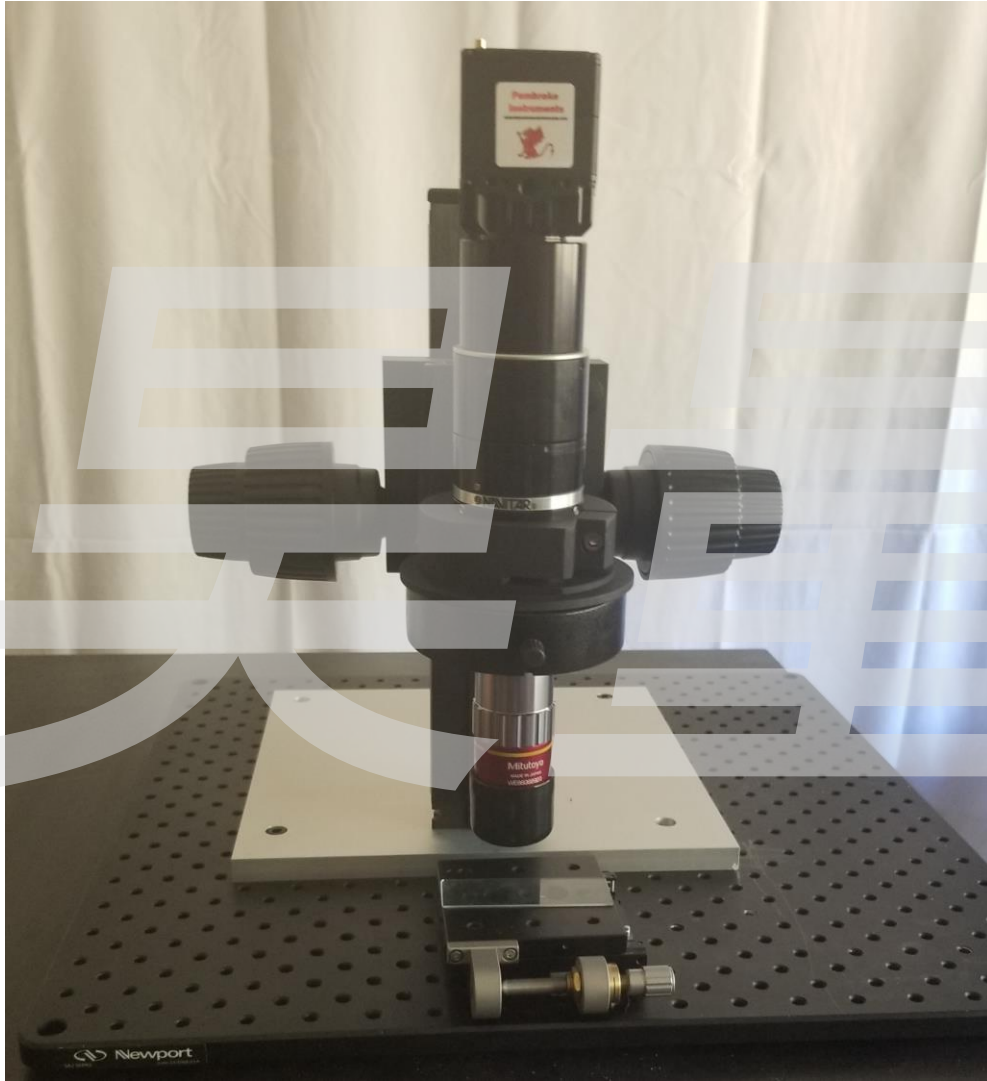

We can mount the microscope optical train onto a standard optical breadboard which will have an array of $\frac{1}{4}$ -20" or M5 threaded holes (left image). With this mounting the user will have great flexibility in selecting and mounting standard translation stages to move the sample in X-Y-Z direction with micron position. Motorized stages and light sources can be easily mounted to the microscope breadboard and replaced quickly with components needed for the particular application.

2. Spectral Range Requirements

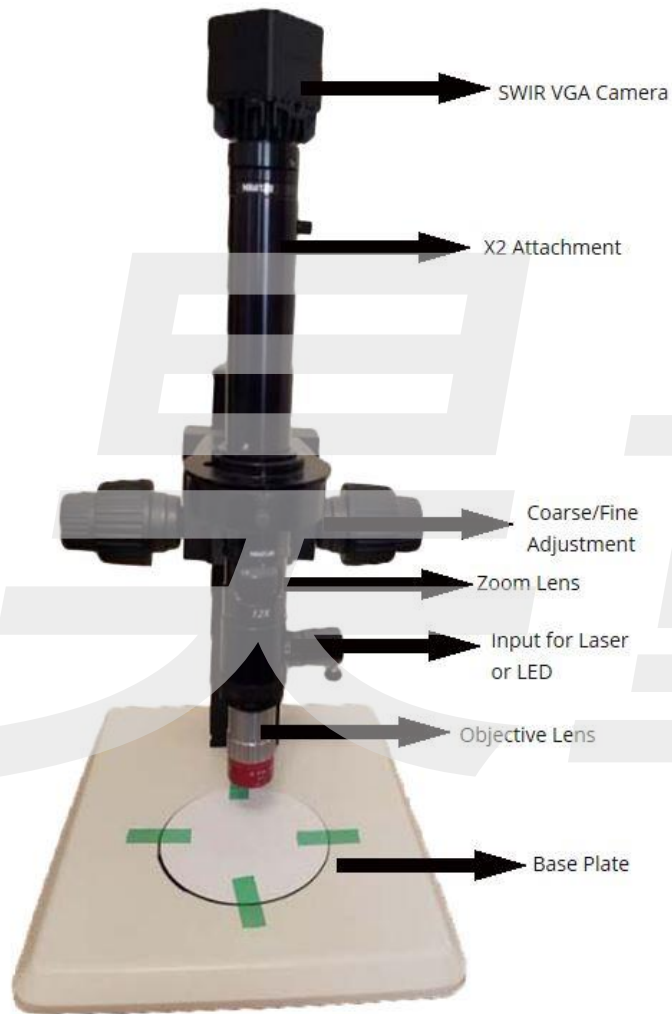

Your target sample may emit SWIR light naturally or when it is illuminated by an external light such as an LED or laser. You must know ahead of purchasing a configuration what spectral range you need to image. The most common configurations will support imaging between 900-1700 nm. If spectral imaging requirement is broader than 900-1700 nm, the cost of the microscope will increase quite a bit.

It is possible to insert long pass or bandpass filters between the camera sensor and the microscope optical train. Many standard filters are available between 900-2500 nm and custom filters can be manufactured at customer request.

3. Fixed or Range in Magnification

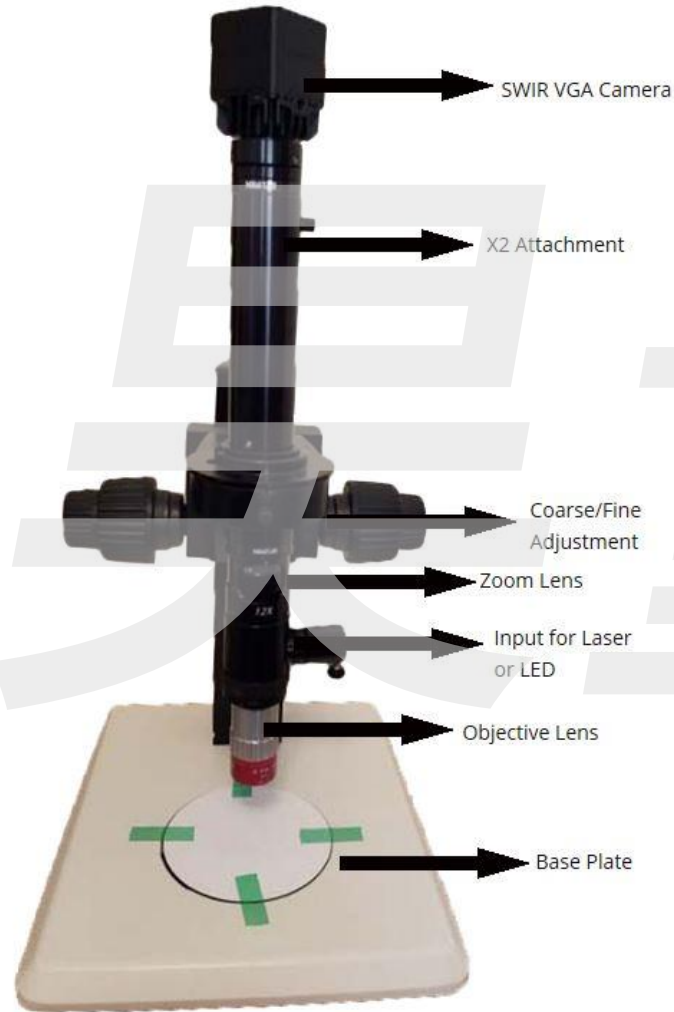

You have to decide if your application requires fixed or a range in magnification. Some applications need only one magnification and some savings can usually be achieved if you configure the microscope without optics that will allow you to zoom in/out on the sample. The microscope design is usually flexible enough to allow a user to add zoom capability after using it on work samples. Zoom lenses included in the optical train can provide at least an X7 swing in magnification. **Vignetting at the low end of zoom lens magnification can be an issue and this is dealt with by increasing the magnification of the zoom lens.**

4. Working Distance

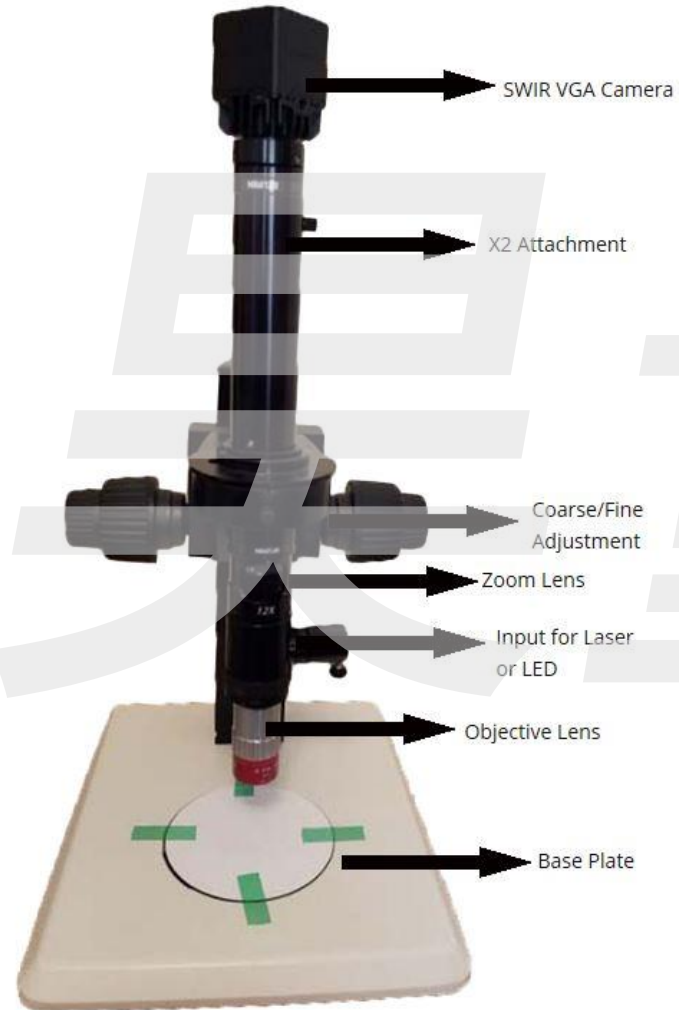

Working Distance (WD) is the distance in mm between the tip of the objective lens and your target sample. The typical WD of most objective SWIR lenses is about 23 mm. You must make sure ahead of time that there is enough clearance between the bottom of the microscope stand baseplate and the objective lens. Make sure that the height of the vertical carrier (the vertical support post which holds the optical train) is tall enough to give you the clearance you need, not only for the sample but for any translation stage you want to use to hold and move the sample to the center of the objective lens FOV. Focus will be achieved through coarse/fine adjustment of the optical train vertical height relative to your sample.

5. Illumination Requirements

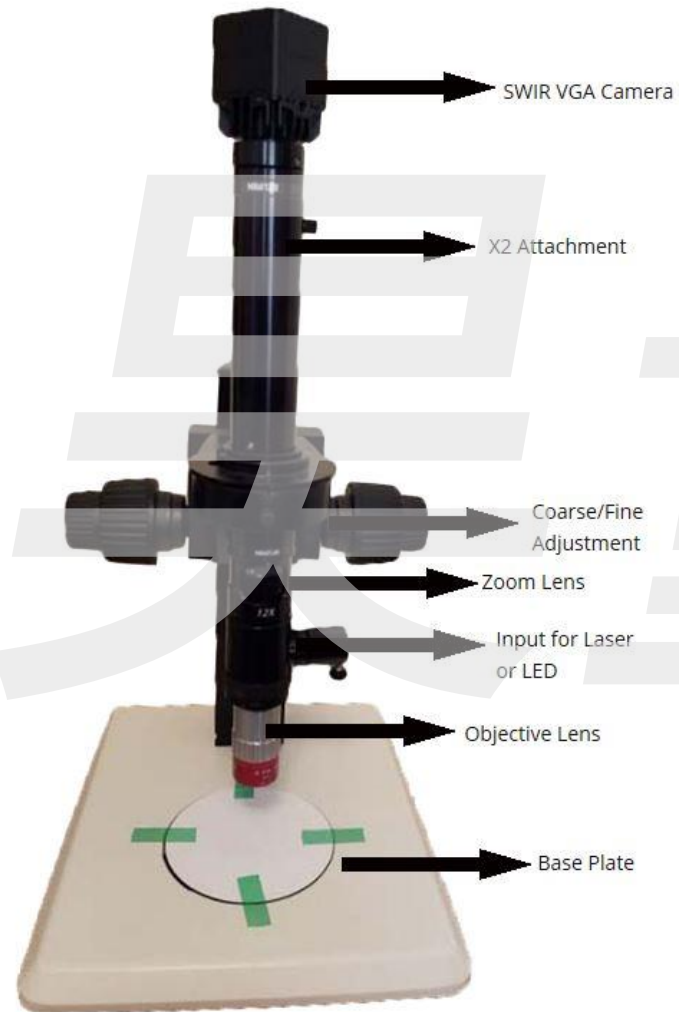

Most microscope configurations will support co-axial illumination whereby collimated external light is delivered through an optical segment attached to the objective lens. The co-axial segment contains optics which will direct light dead center through the objective lens and focused on the sample. Reflected light from the sample will pass through the objective lens and co-axial segment and be delivered collimated to camera sensor. We support many types of sample illumination including broadband sources, LED's, and lasers. The microscope can be configured to accept collimated laser light from either SMA or FC/PC connectors.

6. Sensor Selection

Your selected SWIR camera must be aligned with all other spectral requirements for the microscope configuration including:

1. The spectral range of the light reflected or emitted by the sample
2. The SWIR sensor in the camera must have sufficient sensitivity, dynamic range, noise performance required by the application.
3. The sensor should not be the limiting factor for image spatial resolution.

In general, applications requiring $> X20$ magnification will need a TE cooled sensor as the lower field of view means less light will be delivered to the camera sensor. Applications with a wide FOV and strong sample illumination may be supported with a lower cost uncooled SWIR sensor. Discuss the sensor selection with the applications engineer.

We will calculate the camera resolve limit within the FOV's that you want. For example, the camera resolve limit within a 0.1 mm X 0.1 mm could be 5 microns.



7. Software Options



Software options are usually determined by what tools are available with the camera and that is also impacted by the camera data port you select (USB3, Cameralink, GigEVision, or analog video). Cameras usually come with a GUI, SDK, and drivers for Labview and Matlab. Other supported software tools include a bridge to MicroManager which can support common microscope functions for image analysis. It is important to discuss what software tools you will need for your application with a support engineer.



8. Microscope Stand Options

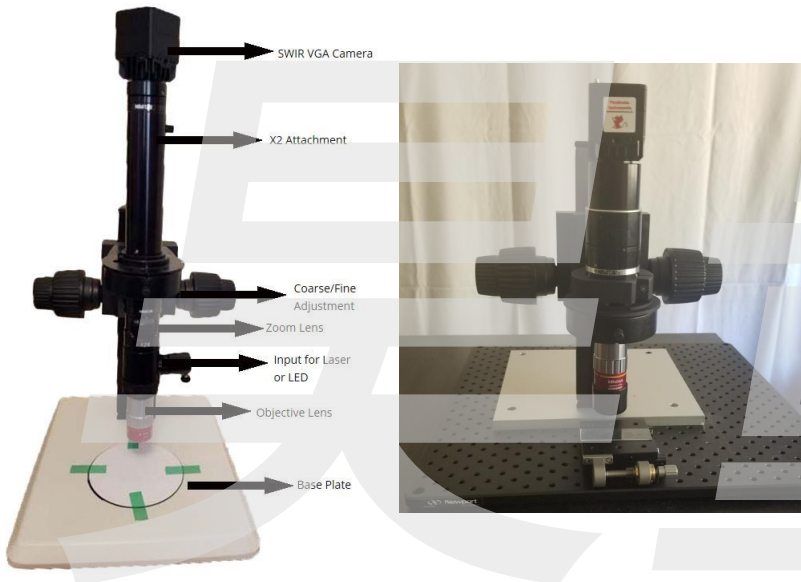

At a minimum, the microscope stand must support very stable attachment and control of the microscope optical train. This is especially true for applications with $> X10$ magnification as image jitter will occur unless your stand is mechanically stable. The coarse/fine adjustment control must not exhibit backlash when you focus the image. Less expensive stands will usually exhibit backlash and it will be a frustrating experience and expensive to rectify, so this is an issue that should be discussed with the applications engineer. If you need flexibility to using X-Y translation stages with micron precision, we suggest attaching the vertical carrier to a standard optical breadboard with 1" spaced blind holes for $\frac{1}{4}$ -20 standard attachment screws. We can customize your microscope configuration for your choice of breadboard, translation stages, and light sources.

9. Sample Mounting and Control



In many applications, the microscopist will need to move the sample very precisely and with micron accuracy once good focus has been achieved. These are readily available from well know vendors for translation stages. If you employ such stages, we suggest your stand should have a standard optical breadboard with a matrix of blind holes spaced 1" apart with either M5 or ¼-20 UNC blind holes. As you configure your microscope, make sure you have enough vertical clearance to support these stages.

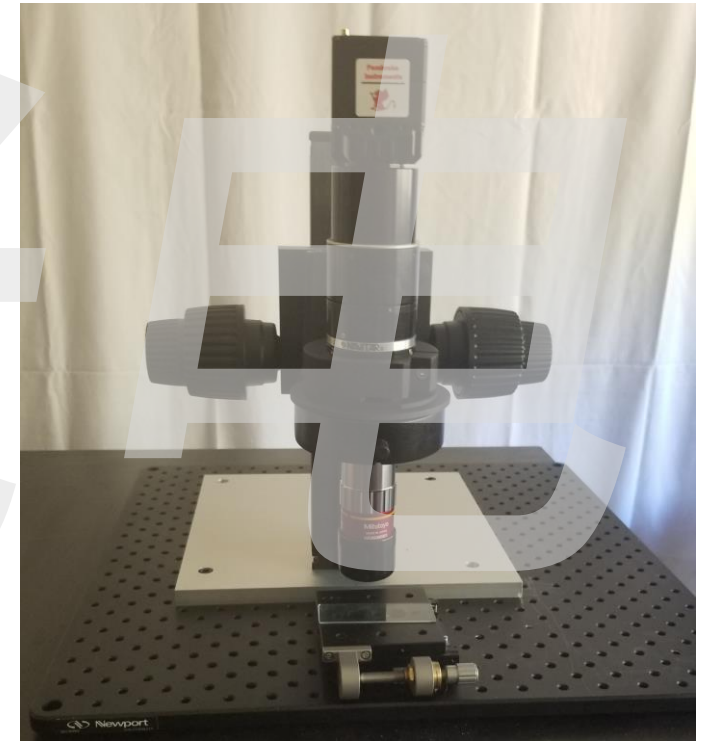

10. Additional Guidance

Use this guidance document as a tool to present your SWIR microscope requirements to a quoting engineer. This will enable fast quoting and also makes sure that the SWIR microscope product you purchase will be exactly aligned with your application(s).

If you have any questions about this guidance document please email info@auniontech.com

