

Retardance Measurement Station

Meadowlark Optics' Retardance Measurement Station, Model TB1000, is the first commercial product for high precision measurements of waveplates. Customer demand triggered the development of the TB1000. This turnkey, fully-enclosed system measures the retardance of multi-order waveplates and same-material compound zero-order waveplates (Sapphire, Magnesium Fluoride, and Quartz). The TB1000 is versatile and portable and can be easily moved from the R&D lab to the production floor, bringing the precision of Meadowlark Optics Metrology Services from our lab to yours.

Retardance measurements are obtained in under 2 seconds with the user-friendly software in just one click. A reference retarder is included with each shipment to ensure the system is meeting the calibration as measured at the factory prior to shipping.

Optional items can be added to the TB1000. The standard system has alignment marks to assist in placement of the waveplate on the measurement bay. This area can be customized per the user's crystal dimensions with our drop-in alignment guide, which ensures that measurements are spatially accurate each and every time.



Key Features

...

Retardance measurements in under 2 seconds with one-click

Highly Repeatable

Fast Axis Alignment Check

Automatic Dark and Bright Reference

User-friendly Software Interface

Reference Retarder Included



Quartz Reference Retarder Included with retardance data over a 7.6 mm area.

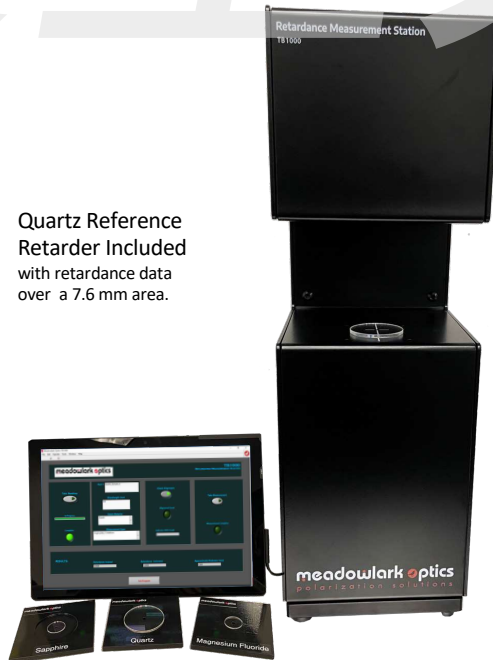

Optional custom drop-in alignment guides →



The TB1000 software is fully automated and provides user's retardance measurements with a simple click. It only takes <2 seconds to obtain accurate, repeatable results.

Due to variation in crystal structure, calculating the retardance based on the thickness of the material using only a listed birefringence can lead to errors. The TB1000 allows an end user to accurately measure the real retardance of each waveplate.

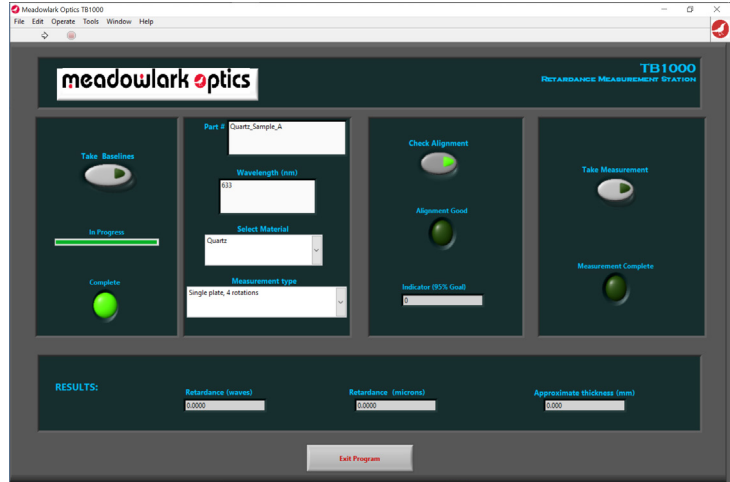

TB1000 Software Interface

Retardance in crystals will change with temperature variation. As a rule of thumb, the retardance (in waves) for a 1 mm thick quartz retarder varies by about -0.5% per °C. For this reason, we encourage regular monitoring of air temperature around the equipment if small retardance changes are concerning. Alternatively, you can use the reference retarder included with the TB1000 to confirm accurate readings.

Sample Measurements using TB1000

| Material | ¹ Measured Thickness in mm | ² Calculated Retardance in nm (waves) | ³ Measured Retardance in nm (waves) |
|------------|---------------------------------------|--|--|
| Quartz A | 3.068 | 27,770 (43.870) | 27,705 (43.768) |
| Quartz B | 1.623 | 14,691 (23.208) | 14,648 (23.142) |
| Quartz C | 0.198 | 1,792 (2.830) | 1,753 (2.771) |
| Sapphire A | 1.733 | 13,976 (22.079) | 13,958 (22.052) |
| Sapphire B | 3.475 | 28,018 (44.262) | 27,984 (44.210) |
| MgF2 A | 2.320 | 27,300 (43.127) | 27,184 (42.945) |
| MgF2 B | 0.483 | 5,789 (9.145) | 5,667 (8.953) |

1. Measured on Heidenhain length gauge.
2. Retardance calculated using $\delta = Bt/\lambda$, using Measured Thickness
3. Measured at 633nm on TB1000.



Retardance Measuring Station

| SPECIFICATIONS | |
|---|--|
| Retardation Range | 0.1 – 45 waves at 630 nm (default) |
| Wavelength measurement range capabilities | 380 nm to 4.5 μ m |
| Maximum optic size (to center) | 8.2" (208 mm) |
| Retardance Accuracy ¹ | 0.005 waves at 630 nm |
| Measurement Rate ² | <2 seconds |
| Measurement Spot Diameter | 3.8 mm |
| Measurement Units | nm, λ (for retardance) or mm (for thickness) |
| Crystal Types | Quartz Sapphire Magnesium fluoride |
| Interfaces | USB 2.0 |

¹ Highest retardance accuracy obtained with four measurements.

² Minimum speed retardance is obtained.

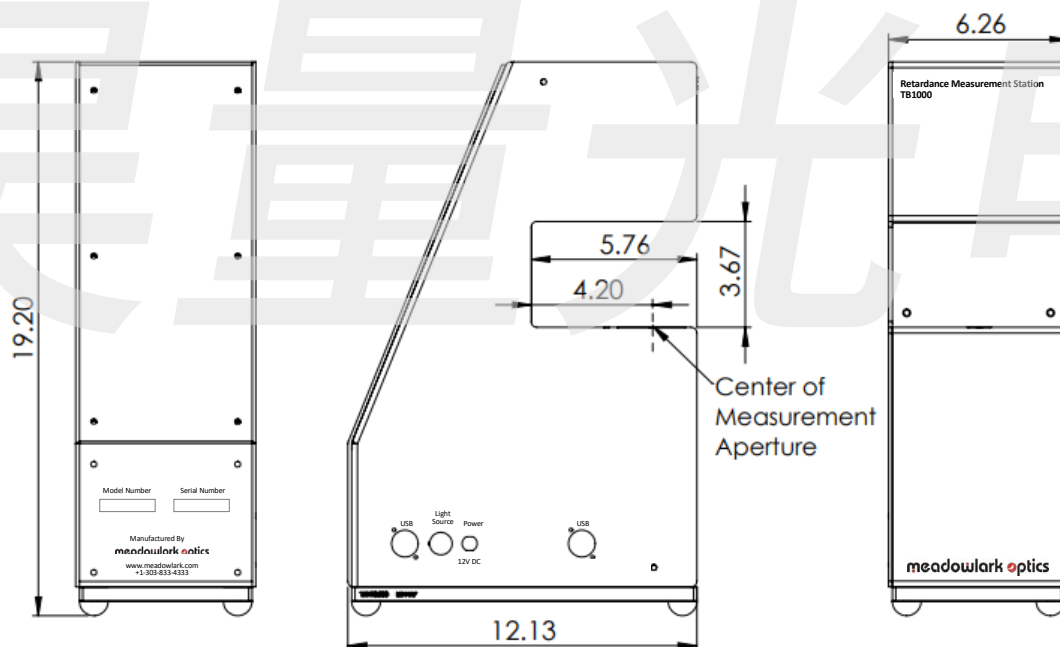

| ORDERING INFORMATION | |
|------------------------------|-------------|
| Item | Part Number |
| Retardance Measuring Station | TB1000 |
| Optional Sample Holder Kit | TB1000-SHK |