

# Datasheet: MMS-1A-RS & MMS-1X-RS

## SENIS® True 3-axis Magnetic Field Mapper MMS-1A-RS & MMS-1X-RS

**SENIS® Magnetic Field Mapper** is designed to precisely measure the magnetic field generated by permanent or electro magnet devices that exhibit axial and radial multipolar magnetization, as is the case with rotors or stators.



**Figure 1:** MMS-1A-RS - Standard Size Mapper



**Figure 2:** MMS-1X-RS - Large Size Mapper

### DESCRIPTION:

SENIS® MMS-1A-RS & MMS-1X-RS, is a high-end fully automated Magnetic Field Mapping System that allows users to perform a fast, high resolution mapping of magnetic field around permanent magnets, electromagnets and electronic circuit PCBs. Due to unique features of the applied fully integrated true 3-axis Hall probe, all three components of the magnetic field are measured simultaneously at virtually the same point. A motion control unit allows for the simultaneous control of four axes (X, Y, Z-linear modules and rotation stage). It enables a fast probe positioning with the highest accuracy and repeatability. A Renishaw TP20 Touch Sensor prevents probe damage and allows probe positioning by touching. The mapping system is controlled by an intuitive easy-to-use software built on MS Windows platform and LabVIEW. Scanning profiles and measured data visualization are fully customizable. The recalibration process can be completed on-site by customer. Various dimensions of the high-end mapper are available for miniaturized electronic parts or heavy rotors. SENIS also provides mapper versions for inline inspection and automated rotor control.

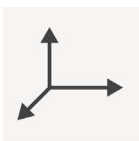

3-Axis Hall probes



Accurate mapping

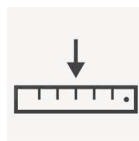

Position repeatability

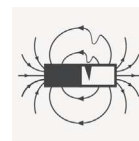

Crack detection

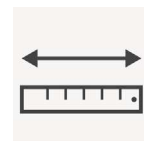

Measurement range

### Why use the SENIS Mapper:

- Measurement of all three components of magnetic field (Bx, By, Bz) simultaneously.
- Calculation of angle error (e.g. for angular control of skewed rotors).
- Multipole magnet analysis - pole width, pole area, zero crossing analysis, number of magnetic poles, field peak amplitude (maximal and minimal value), etc.
- AC magnetic field mapping, sinusoidal shape control, Total Harmonic Distortion, FFT Analysis.
- Quality assessment tool in production with GOOD/BAD analysis, for assemblies such as single and multi-pole permanent magnets, rotors, encoders, loudspeakers, photocopier rollers and magnetic ribbons, smartphones, tablets, PCBs, etc.
- Detection of cracks in permanent magnets.
- Supports the development of magnet systems.
- Applications in laboratories and in production lines, etc.

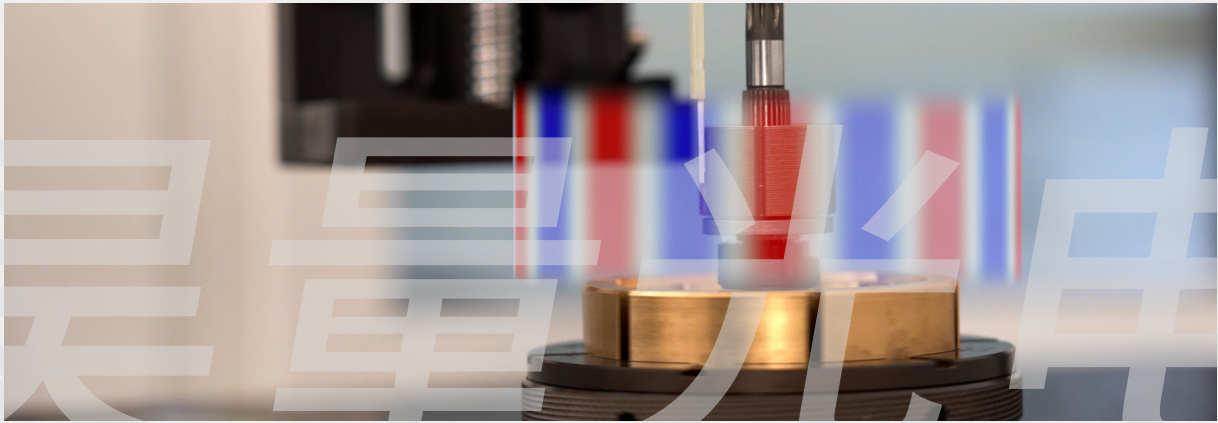

### MMS-1A-RS & MMS-1A-RS Mapper Configuration

- 3-axis Senis Magnetic Field Transducer, including the 3-axis Hall probe.
- Personal Computer including the Motion Control and Data Acquisition Card.
- Electronic box with power supply, magnetic transducer, step motor drivers, encoder electronics, touch sensor control and current supply for calibration tool.
- Cartesian moving platform with linear modules for three axes (X, Y and Z) featuring step motors, boundary switches and Heidenhain optical encoders.
- Non-magnetic rotary stage with encoder for rotating magnets under test with multi-jaw scroll chuck.
- Touch sensor for probe protection and absolute Hall probe positioning.
- Emergency Stop safety equipment.
- Zero Gauss Chamber for Offset Cancelling.
- In-Situ calibration tools.

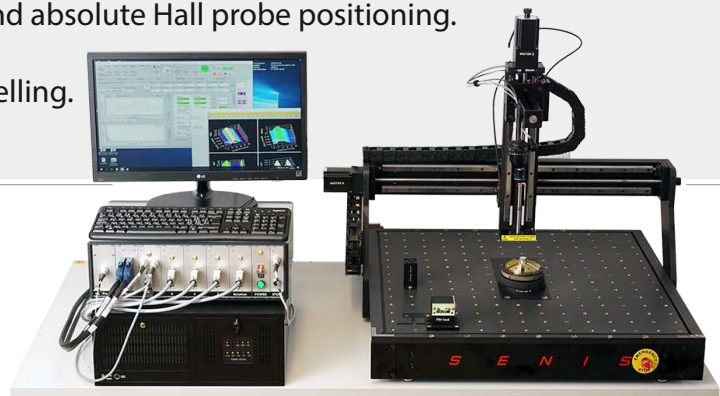

## SPECIFICATIONS:

### Mechanical Specifications

Parameter	Values			
The dimensions of the mechanical part of the scanner	400 mm x 350 mm x 650 mm (Standard size mapper) 820 mm x 900 mm x 815 mm (Large size mapper)			
Total system weight	Mechanical part: Standard size: 26 kg / Large size: 78 kg Electronic module: 7 kg Personal Computer: 2 kg			
Maximal scanning volume (other on request)		X [mm <sup>2</sup> ]	Y [mm <sup>2</sup> ]	Z [mm <sup>2</sup> ]
	MMS-1A-RS	125	125	150
	extended Z-axis	125	125	290
	MMS-1X-RS	570	570	290
extended Z-axis	570	570	380	
Minimal distance of MFSV (Magnetic Field Sensitive Volume) from the magnet	0.3 mm			
Maximal scanning speed	50 mm/s			
Encoder resolution	1 μm (linear); 0.022° (rotational)			
Positioning repeatability	10 μm (linear), 0.05° (rotational) at stable temperature			
Start-up time from cold start till availability for measurement	< 3 min			
Shut down time	< 1 min			
Recovery time from an emergency stop	< 1 min			

### Hall Sensor Specifications

Hall sensor measuring range	Included	± 100 mT
	Optional	± 500 mT
	Optional	± 2'000 mT
Hall sensor resolution	better than 0.02% for measurement range ≥200mT better than 0.05% for measurement range ≤100mT	
Hall sensor accuracy	typical 0.1% of full range (at 23° C)	
System sampling rate	Standard rate (calibrated): 10 kSamples/s per channel 60 kSamples/s, for 3-channels acquisition 200 kSamples/s, for 1-channel acquisition	
Magnetic field Frequency Bandwidth	DC to 25 kHz (-3dB point)	

**Standard Probe types:**

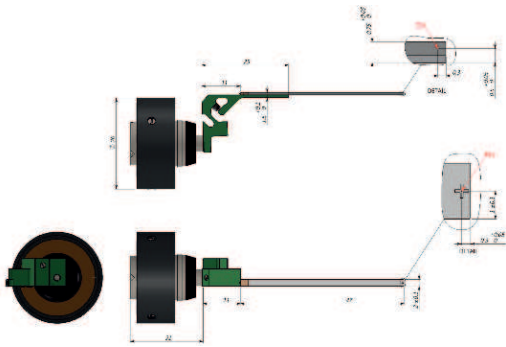

**Figure 3:** Bend holder with HM probe

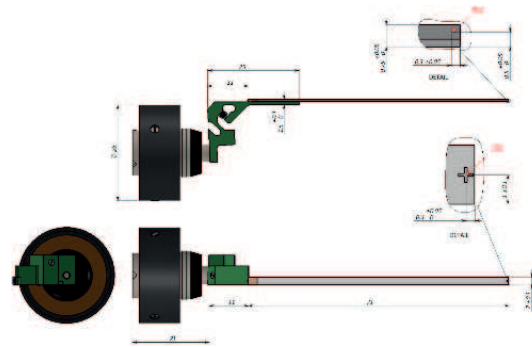
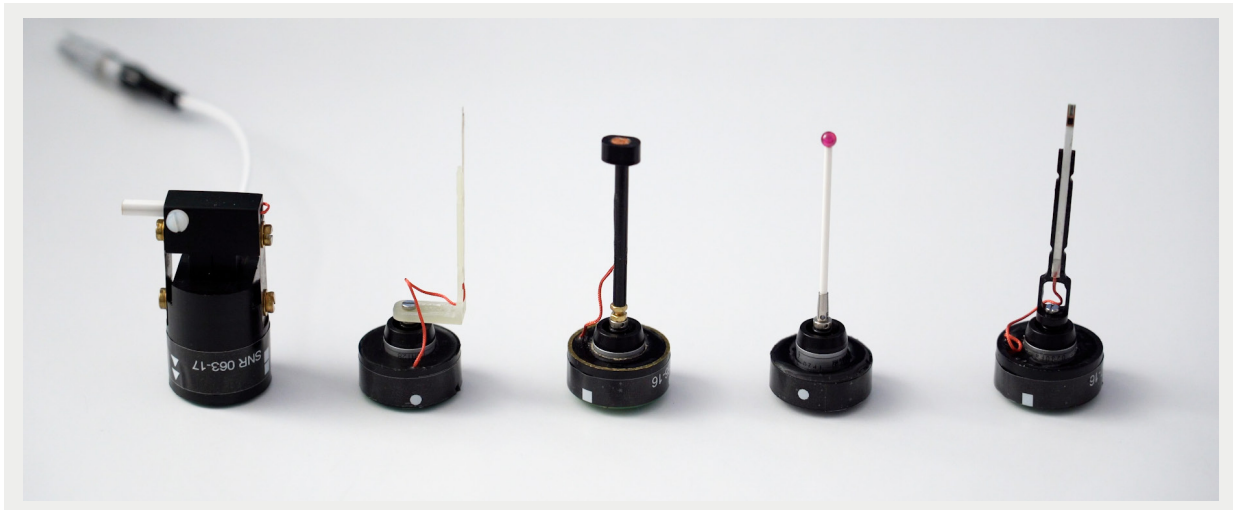

**Figure 4:** Bend holder with HL probe

Denomination	Description	Minimal measuring distance		Dimension (excl. holder)		
		X [mm]	Z [mm]	L [mm]	W [mm]	T [mm]
HM	Ceramic packaged probe	0.25±0.05	0.3±0.05	47	2	0.75
HL	Ceramic packaged probe	0.25±0.05	0.3±0.05	71	2	0.75

**Optionally** SENIS can provide special probes (on request and depending on mapper configuration):

- 3-axis extra long Hall probe (ext. dim. 115.0 x 2.0 x 0.75 mm)
- AMR probes with very high magnetic field resolution for measuring of very low magnetic fields (Magnetic field range: 0.5mT; Magnetic resolution: better than 100nT)
- Eddy Current probe for crack detection in magnetized and non-magnetized parts
- Other customized probe solutions



## SOFTWARE:

SENIS' mapper software provides real-time and off-line analysis and visualization of measured magnetic field data; it generates a 3D map of the magnetic field, counts number of poles, calculates pole width for multipole magnets and rotors. It detects zero crossings, measures magnetic angle, angle error and field homogeneity. It provides GOOD/BAD decisions, detects cracks in magnets and in non-magnetized blanks and much more.

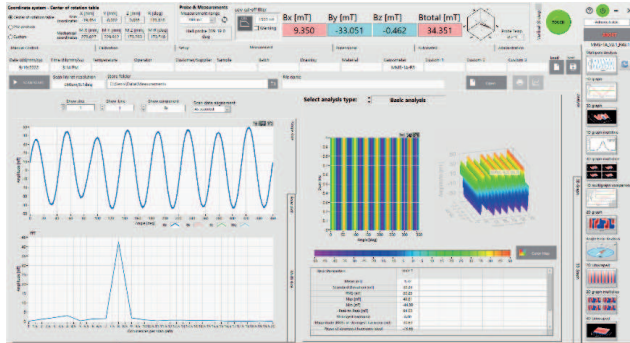

Measurement analysis

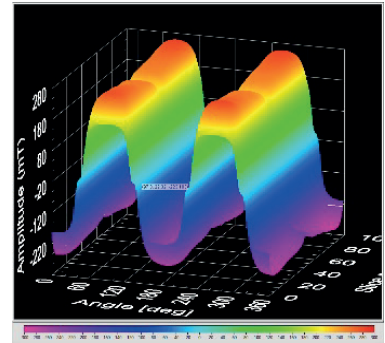

3D view

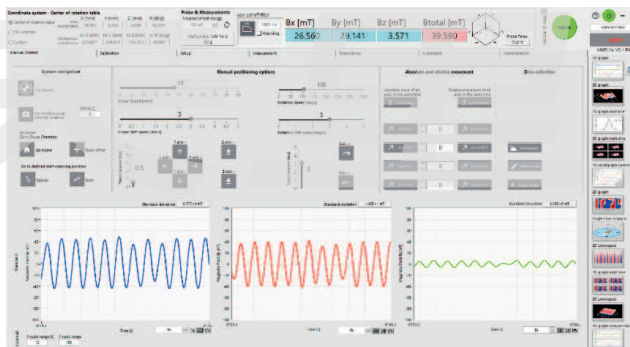

Manual control page

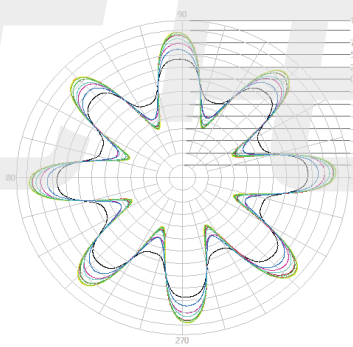

Polar plot view

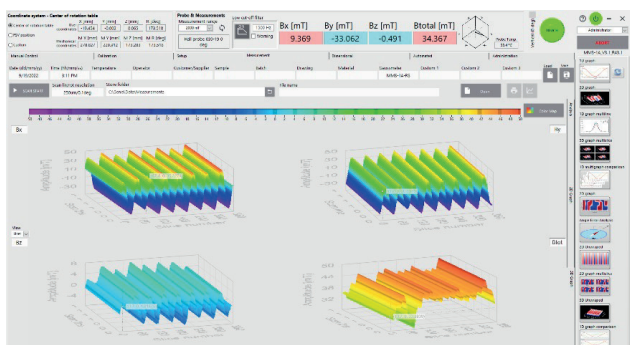

3D analysis of all components at once

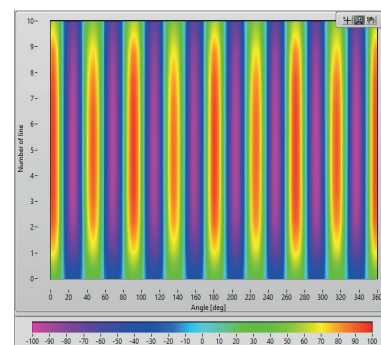

2D view

## Training and Support:

We provide installation and training by SENIS experts at your facility or on-line. Additional training can be arranged at your facility. We'll be happy to create a custom training plan to fit your needs.

## Other Mapper Solutions available:



**MMS-2A-ROT**



**M3D-2A-PORT**



**Customized**

- **MMS-2A-ROT:** 3D magnetic field mapping of cylindrical magnets - rotors, disk, ring and segment magnets
- **M3D-2A-PORT:** Light and small portable mapper
- **Customized solutions**

## About SENIS AG:

**SENIS AG**, Switzerland is a leading company that provides smart and accurate sensors and instruments for magnetic field and electric current measurements. We engineer advanced solutions and ensure that our customers' systems are innovative, optimized and reliable. With our products we help control energy consumption, contribute to the optimization of green car platforms and systems, provide high accuracy for medical equipment and continuously contribute to the transition to a sustainable future. We collaborate with customers and universities, pushing innovation with cutting edge technologies.