

### DESCRIPTION

The 3NTA2 Nanoteslameter is a high performance magnetic field measuring instrument based on the high magnetic resolution Anisotropic Magneto Resistance (AMR) sensors, for measurement of the magnetic field from nT (nano Tesla) up to 100 $\mu$ T (1 gauss).

SENIS provides 1-, 2-, or 3-axis Nanoteslameters that include one compact AMR probe with very high spatial resolution (few millimeters), an electronic module for signal conditioning and user-friendly LabVIEW software for data acquisition and visualization. The electronic module made of non-ferrite materials includes a power supply unit, data acquisition card with 16bit AD converters, signal amplifiers, temperature compensation and probe biasing unit. The probe cable can be extended up to 40m by use of a special electronic interface.

There is a possibility to expand the measuring range up to 500 $\mu$ T (5 gauss).

### KEY FEATURES

- **Measurement range: 1nT – 0.1mT<sup>(1)</sup>**
  - **Measurement accuracy: <1%**
  - **Magnetic field resolution: 500pT<sup>(1)</sup>**
  - **Noise Spectral Density: 1nT/ $\sqrt$ Hz<sup>(1)</sup>**
  - **1-, 2-, 3-axis AMR probe**
  - **Very small probe dimensions**
  - **High spatial resolution: 1.25x0.5x0.25mm**
- <sup>(1)</sup> *Data for a measuring range of 100  $\mu$ T*

### TYPICAL APPLICATIONS

- **Monitoring and active cancelation of environmental magnetic fields**
- **Measuring stray magnetic fields of electrical machines**
- **Directional drilling**



Figure 1: Photograph of the Nanoteslameter

## Dimensions and characteristics

Probes for Nanoteslameter are based on the Anisotropic Magneto Resistance sensors (AMR) for measurement of very low magnetic fields from nT (nano-Tesla) up to  $100\mu\text{T}$  (1 gauss). Probes can be assembled to measure one component of the magnetic field, two components or all three components of the magnetic field.

All probes have same dimensions and are made very small and compact in order to allow magnetic field measurements in a small spatial area. The photograph of the probe shown in figure 2, dimensions of the field sensitive volume (FSV) is shown in figure 3 and dimensions of the AMR probe and the FSV position are shown in figure 4.

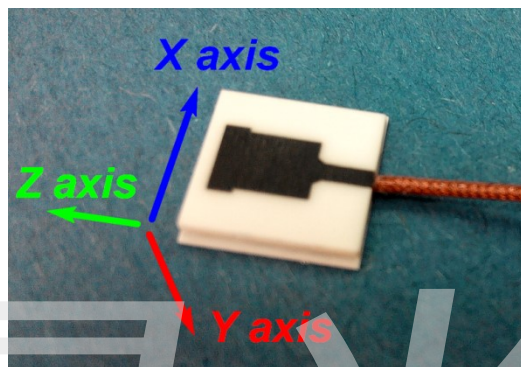

Figure 2: Photo of AMR probes with direction of the sensitivity axis

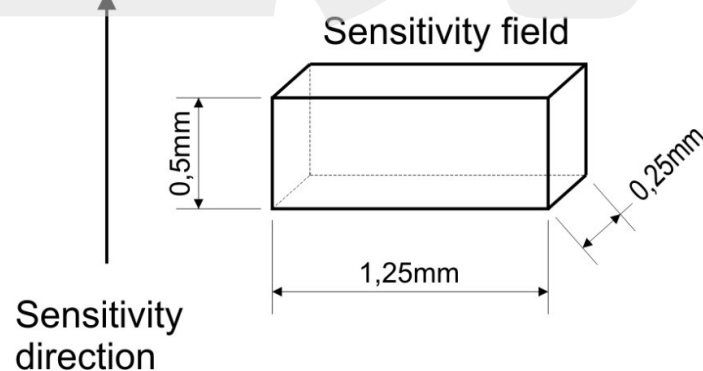

Figure 3: Field sensitive volume of AMR sensors

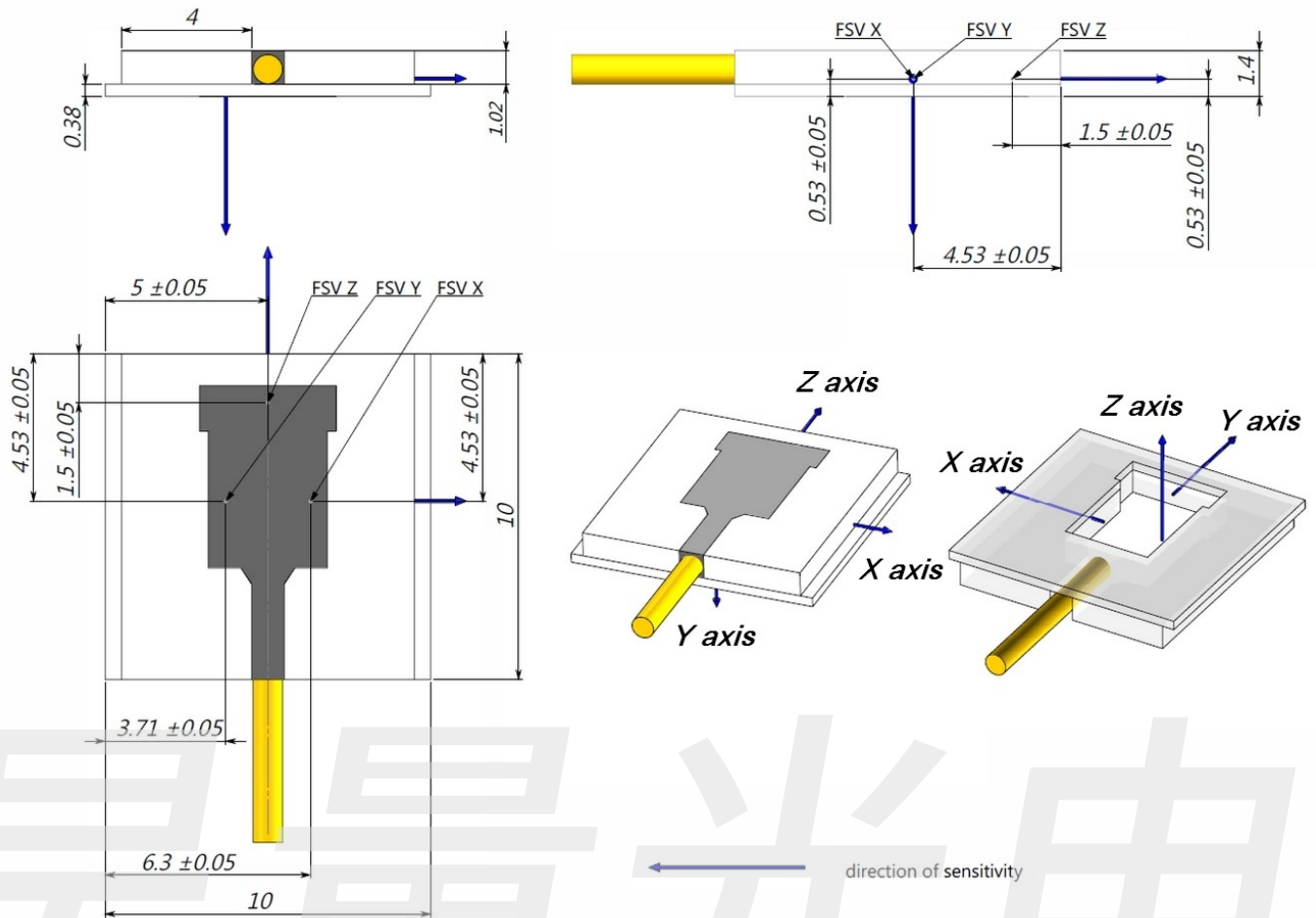

Figure 4: Mechanical drawing of probe AMR-OXS and position of FSV (dimension are in millimeters)



Figure 5: Photo of the front side of Electronic Interface 3NTA2 – EI



Figure 6: Cable extension electronic interface: the cable length from 2m to 40m and more

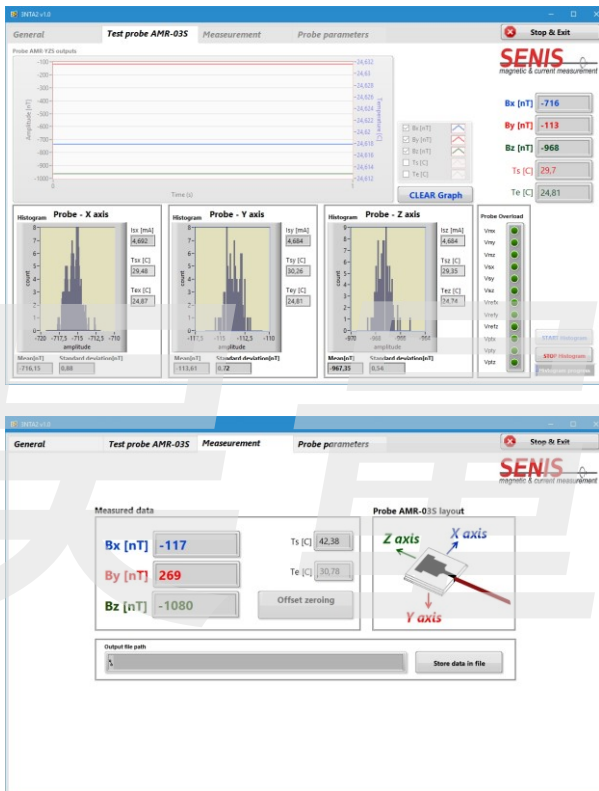

	A	B	C	D	E	F	G
3	Output file name: C:\3NTA2\08_06_17_Data_09-17.txt						
4							
5	Time	B zeroing	Bx [nT]	By [nT]	Bz [nT]	Ts [C]	Te [C]
6							
7	09:17:49	FALSE	-97	233	-1078	36,4	23,1
8	09:17:50	FALSE	-97	232	-1079	36,4	23,09
9	09:17:51	TRUE	0	1	1	36,4	23,09
10	09:17:52	TRUE	0	0	1	36,4	23,09
11	09:17:53	TRUE	0	1	0	36,4	23,09
12	09:17:54	TRUE	1	0	0	36,4	23,09
13	09:17:55	TRUE	0	1	1	36,4	23,1
14	09:17:56	TRUE	0	0	0	36,41	23,1
15	09:17:57	TRUE	1	0	0	36,41	23,09
16	09:17:58	TRUE	0	1	1	36,41	23,1
17	09:17:59	TRUE	-1	0	0	36,41	23,09
18	09:18:00	TRUE	0	0	0	36,41	23,09
19	09:18:01	TRUE	0	0	1	36,41	23,09
20	09:18:02	TRUE	0	1	1	36,41	23,09
21	09:18:03	TRUE	0	0	1	36,41	23,09
22	09:18:04	FALSE	-98	233	-1078	36,41	23,1
23	09:18:05	FALSE	-98	233	-1078	36,41	23,1
24	09:18:06	FALSE	-97	233	-1078	36,41	23,1

Figure 7: Nanoteslameter Software: measured data visualization with histograms, test data for calibration, measured data export to excel sheet for further analysis