

Datasheet: F3B MAGNETIC FIELD TRANSDUCERS

High Spatial Resolution Magnetic Transducers with Fully Integrated 1-, 2-, 3-axis Hall Probe

*** Replacement of the model F3A Magnetic Field Transducer ***

DESCRIPTION:

The **F3B** denotes a range of SENIS Magnetic Field-to-Voltage Transducers with fully integrated 3-axis Hall Probe.

The Hall Probe contains a CMOS integrated circuit, which incorporates three groups of mutually orthogonal Hall elements, biasing circuits, amplifiers, and a temperature sensor. The integrated Hall elements occupy very small area ($150 \times 150 \mu\text{m}^2$), which provides very high spatial resolution of the probe. The CMOS IC technology enables very high precision in the fabrication of the vertical and horizontal Hall elements, which gives high angular accuracy of the three measurement axes of the probe (orthogonality error $< 1^\circ$, determined with an accuracy of better than 0.1°).

The application of the spinning-current technique in the biasing of the Hall elements suppresses the planar Hall effect. The on-chip signal pre-processing enables a very high frequency bandwidth (DC to 25 kHz) of the probe, and on-chip signal amplification provides high output signals of the Hall probe, which makes the transducer immune to the external electromagnetic disturbances.

The Hall probe is connected with an electronic box (Module E in Fig. 1). The Module E provides biasing for the Hall probe and additional conditioning of the Hall probe output signals: amplification, linearization, cancellation of the offsets, compensation of the temperature variations, and limitation of the frequency bandwidth.

The outputs of the F3B Magnetic Transducers are available at the connector CoS of the Module E:

- three high-level differential voltages (V_x , V_y and V_z) proportional with each of the three measured components (B_x , B_y and B_z , respectively) of a magnetic flux density, and
- a ground-referred voltage (V_{pt}) proportional to the actual temperature of the Hall sensor.

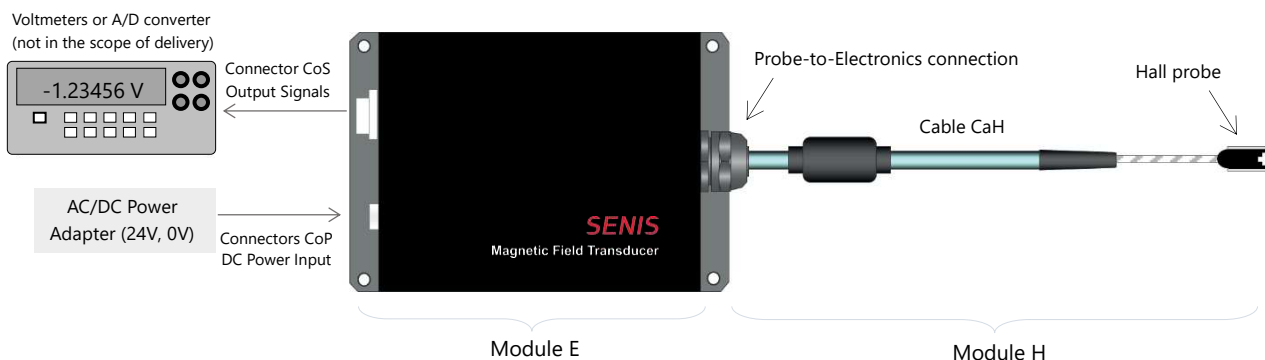

Figure 1: Typical measurement setup with a SENIS magnetic-field-to-voltage transducer with fully integrated 3-axis Hall Probe (Module H) and Electronic (Module E)

KEY FEATURES:

- Fully integrated CMOS 3-axis Hall Probe (Bx, By, Bz), of which one, two or three channels are used
- Very high spatial resolution: By: $0.03 \times 0.005 \times 0.03 \text{ mm}^3$; Bx & Bz: $0.15 \times 0.01 \times 0.15 \text{ mm}^3$
- High angular accuracy: orthogonality error between the three measurement axes of the probe is $< \pm 1^\circ$, determined with an accuracy better than 0.1° by the application of a well-improved measurement algorithm
- High frequency bandwidth: maximum: DC to 25 kHz (-3 dB)
- Very low planar Hall voltage
- Integrated temperature sensor in the probe for temperature compensation
- Negligible inductive loops on the probe

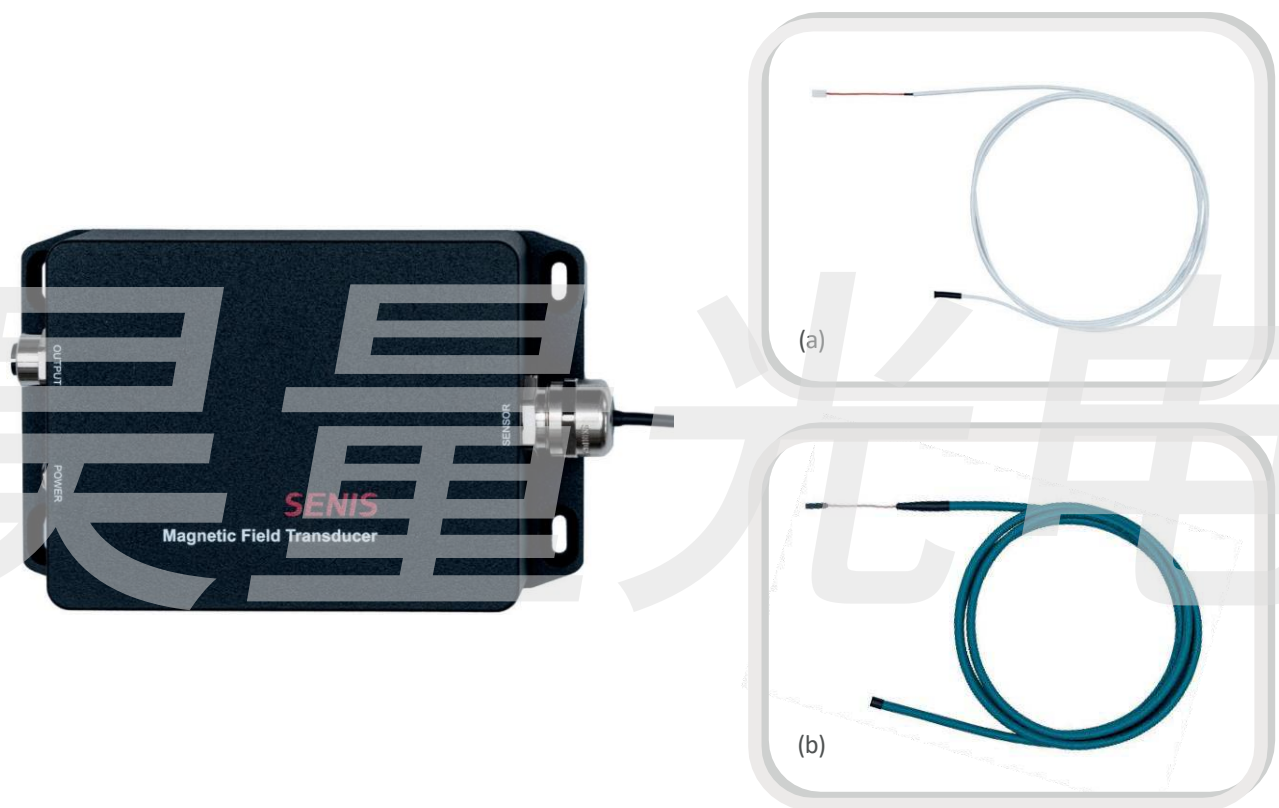







Figure 2: Photos of the 3-axis magnetic field transducers F3B with fully integrated 3-axis Hall Probe. Two cable variants are available: (a) white cable (thin, OD 1.7 mm); (b) blue-marine cable (thick, OD 6.5 mm).

TYPICAL APPLICATIONS:

- Characterization and quality control of permanent magnets
- Development of magnet systems
- Real 3D magnetic field mapping
- Quality control and monitoring of magnet systems (generators, motors, etc.)
- Application in laboratories and in production lines

Module H - SPECIFICATIONS:

The F3B magnetic field transducers apply a number of different geometries/dimensions of Hall probes, which fulfills a wide range of application requirements:

Hall Probe Type:	External Dimensions: L x W x H (mm)	Magnetic Field Sensitive Volume MFSV (μm^3)
Type A ¹⁾ 	A: 16.5 x 5.0 x 2.3	Bx, Bz: 150 x 10 x 150 By: 30 x 5 x 30
Type C ²⁾ 	C: 8.0 x 4.0 x 0.9	
Type H ³⁾ 	HL: 71.0 x 2.0 x 0.5 HM: 47.0 x 2.0 x 0.5 HS: 8.0 x 2.0 x 0.5	
Type K ⁴⁾ 	KL: 71.0 x 2.0 x 0.5 KM: 47.0 x 2.0 x 0.5 KS: 8.0 x 2.0 x 0.5	
Type L ⁵⁾ 	LL: 71.0 x 2.0 x 0.5 LM: 47.0 x 2.0 x 0.5 LS: 8.0 x 2.0 x 0.5	

The Hall sensor chip is embedded in the probe package and connected to the CaH cable.

REMARKS:

- 1) Very robust package.
- 2) Standard, robust, very compact ceramics package.
- 3) Narrow and thin package with mechanically protected chip. It comes in 3 lengths: long (L), medium (M) and short (S).
- 4) Narrow and thin package. The silicon die is naked from the top side to achieve very small measurement distances. It comes in 3 lengths: long (L), medium (M) and short (S). Caution: The naked die is sensitive to touch.
- 5) Narrow and thin package with the naked Si chip on the probe tip. Dimensions of the naked Si-chip (L x W x H): 2.7 x 0.64 x 0.28 mm. It is available in 3 lengths: long (L), medium (M) and short (S). Caution: The naked silicon die is very sensitive to touch.

For Hall probe selection please see the list of the available Hall probes at:

<https://www.senis.swiss/magnetometers/#hall-probes>

PROBE CABLE (CaH) - DIMENSIONS & TOLERANCES:

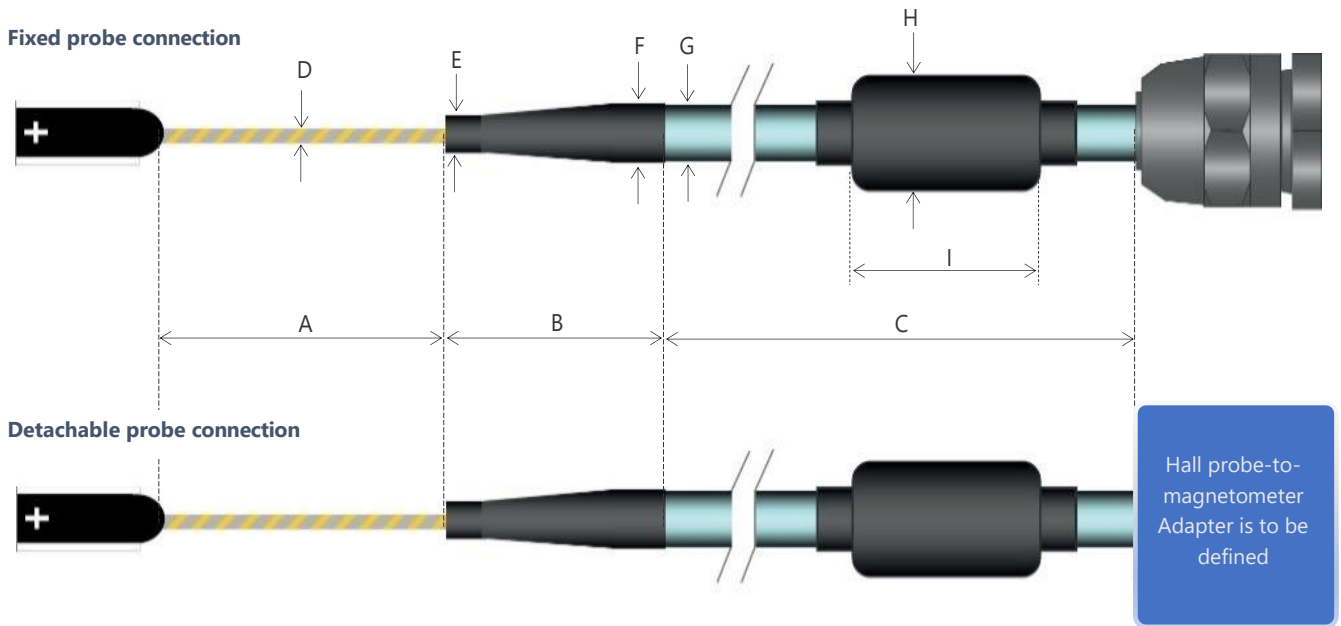

Figure 3: Dimensions of the Hall probe-to-transducer Cable CaH

Dimension	Measure	Remark
A	50 ± 1 mm	Standard for all probes (A, C, H, K and L) Optional: maximum up to 1'000 mm
B	40 ± 2 mm 30 ± 2 mm	Applied to A probe Applied to C, H, K and L probes
C	2 m 5 m	Different lengths available upon a request
D	Ø 1.7 ± 0.2 mm Ø 0.7 ± 0.1 mm	Standard for A probe Standard for C, H, K and L probes
E	Ø 3.3 ± 0.3 mm Ø 2.1 ± 0.2 mm	Standard for A probe Standard for C, H, K and L probes
F	Ø 7.0 ± 0.5 mm Ø 2.1 ± 0.2 mm	Standard for A probe Standard for C, H, K and L probes
G	Ø 6.5 ± 0.2 mm Ø 1.7 ± 0.2 mm	Standard for A probe Standard for C, H, K and L probes
H	Ø 16 mm	Applied only for A probes connected with the thick cable (OD 6.5 mm)
I	30.0 ± 0.5 mm	

MAGNETIC AND ELECTRICAL PERFORMANCES:

NOTE: Unless otherwise noted, please allow for 15 minutes warm up time to achieve optimal performances.
The listed specifications apply for all three measurement channels at room temperature (23 ± 1) °C.

Parameter	Value	Value	Value	Value	Remarks
Standard measurement range (full scale, ±B _{FS}) *	±0.1 T	±0.2 T ±0.5 T	±1 T ±2 T ±3 T	±5 T ±10 T ±20 T	No saturation of the outputs. Other measurement ranges available
Linear range of magnetic flux density (±B _{LR})	±0.1 T	±0.2 T ±0.5 T	±1 T ±2 T ±2 T	±2 T	Optimal, fully in-Laboratory calibrated measurement range
Measurement DC accuracy @ B < ±B _{LR}	<i>High</i> <i>Low</i>	< 0.1 % < 1 %	< 0.1 % < 1 %	< 0.1 % < 1 %	Measured at DC fields as % of full scale. See note 1
Output voltages		Differential (±10 V @ ±B _{FS})			See note 2
Magnetic sensitivity (S)	100 V/T	50 V/T 20 V/T	10 V/T 5 V/T 3.3 V/T	2 V/T 1 V/T 0.5 V/T	Measured at DC fields. Differential outputs. See note 3
Tolerance of sensitivity (S _{err}) @ B < ±B _{LR}	<i>High</i> <i>Low</i>	< 0.03 % < 0.3 %	< 0.03 % < 0.5 %	< 0.03 % < 0.5 %	See notes 3 and 4
Nonlinearity (NL) @ B < ±B _{LR}	<i>High</i> <i>Low</i>	< 0.05 % < 0.2 %	< 0.05 % < 0.2 %	< 0.05 % < 0.5 %	See note 4
Planar Hall voltage (V _{planar}) @ B < ±B _{LR}		< 0.01 % of V _{normal}			See note 5
Temperature Coefficient of Sensitivity		< ±100 ppm/°C (0.01 %/°C)			@ Temperature range: (25 ± 10) °C
Long-term instability of Sensitivity		< 1 % over 10 years			
Offset (@ B = 0 T)	< ±0.1 mT	< ±0.3 mT	< ±0.6 mT	< ±2 mT	@ Temperature range: (25 ± 5) °C
Temperature Coefficient of the Offset	< ±0.002 mT/°C	< ±0.005 mT/°C	< ±0.05 mT/°C	< ±0.4 mT/°C	
Offset fluctuation & drift (@ 0.01-10 Hz, eg., Δt=0.05 s, t=100 s)	< 0.03 mT	< 0.04 mT	< 0.1 mT	< 0.7 mT	Peak-to-peak values. See note 6
Output Noise:					
Noise Spectral Density @ f = 1 Hz	< 1 μT/Hz ^{1/2}	< 2 μT/Hz ^{1/2}	< 7 μT/Hz ^{1/2}	< 40 μT/Hz ^{1/2}	Region of 1/f noise
Corner frequency (f _c)		~10 Hz			Where 1/f noise = white noise
Noise Spectral Density @ f > f _c	0.7 μT/Hz ^{1/2}	0.8 μT/Hz ^{1/2}	2 - 3 μT/Hz ^{1/2}	16 μT/Hz ^{1/2}	Region of white noise
Broad-band Noise (@ f > f _c)		Depends on the adjusted Frequency Bandwidth (Bw)			RMS noise. Peak-to-peak noise is ~5-6 times higher. See note 7
Resolution					See notes 6 - 10
Typical frequency response:					
Frequency Bandwidth (Bw)		0.5 kHz 2.5 kHz 5.0 kHz 10 kHz max: 25 kHz			Sensitivity attenuation is -3 dB. See note 11
Output resistance		< 1 kΩ, short circuit proof			
Temperature output:					
Voltage-to-ground (V _{PT})		V _{PT} [V] = (T _{Hall} [°C] - 25 °C ± 1 °C) x 0.1 [V/°C] or: V _{PT} [V] = (T _{Hall} [°C] - 25 °C ± 3 °C) x 0.05 [V/°C]			T _{Hall} - the actual local temp. of the Hall sensor. See note 12
Magnetic Flux Density (B) units: tesla (T) – gauss (G):					
1 T = 10 kG 1mT = 10 G 1 μT = 10 mG					

* The device provides only one measurement range – a subject prior to ordering.

F3B TRANSDUCER MODEL NUMBER CHART:

F3	x	-	H1	H2	H3	H4	H5	H6	-	E1	E2	E3	E4	E5	E6	E7	E8
Type ID (3 characters)			Module H (6 or 7 characters)							Module E (8 characters)							

- **F3** Magnetic Field Transducer (MFT) identifier;
- **x** product release version, currently **B**;
- For Module H (6 or 7 characters) and Module E (8 characters) see the document *MFT Model Numbering Chart.pdf*.

OUTLINE DIMENSIONS:

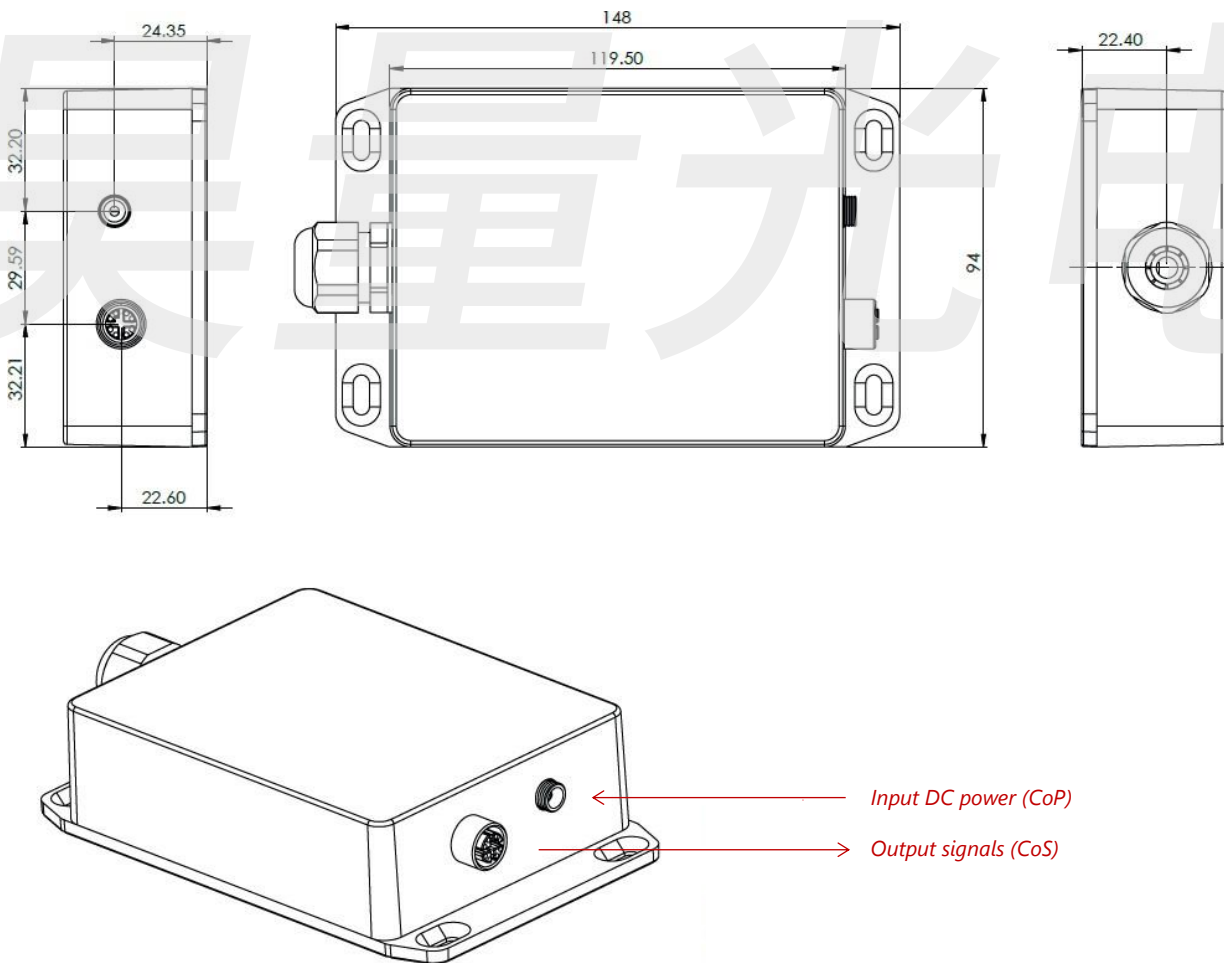
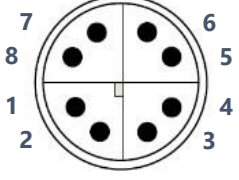

Figure 4: Dimensions of the F3B transducer box. All dimensions are in millimeters (mm).

Module E	High mechanical strength, electrically shielded aluminium case [94 W x 120 L x 38 H mm] with mounting provision (see Fig. 4)		
Connector CoS M12-8L-S-X, 8-pins PCB connector, female (Mating plug: M12-8L-S-X, 8-pins, male)	Field signal X-, X+ Field signal Y-, Y+ Field signal Z-, Z+ Probe Temperature (Vpt) Signal common (GND)	Pins 6 and 5 Pins 4 and 3 Pins 2 and 1 Pin 7 Pin 8	
Connector CoP PJ-066B (Mating plug: EP501B - Power Barrel Connector Plug, ID 2.5 mm, OD 5.5mm)	Power, +24 V Power common (0 V)		
Hall Probe Connector CoH	Fixed connection: <i>Cable gland MS PG11</i>		
DC power consumption	Voltage: Max. Ripple: Current:	24 V nominal, $\pm 2\%$ 100 mVpp ≈ 0.12 A	
Environmental conditions	Operating Temperature: +5 °C to +45 °C Storage Temperature: -20 °C to +85 °C		
Accessories	<ul style="list-style-type: none"> AC/DC Adapter PS-24 (Manufacturer P/N: SDI12-24-UD (CUI Inc.)) : AC Input : 230 - 115 V / 50 - 60 Hz ; DC Output : 24 V/0.5 A ; Output Signals Cable CO20-X (standard length 2 m). 		

NOTES:

- 1) **Accuracy** of the transducer is defined as the maximum difference between the actual measured magnetic flux density and that given by the transducer. In other words, the term accuracy expresses the maximum measurement error. After zeroing the offset at the nominal temperature, the worst-case relative measurement error of the transducer is given by the following expression:

$$\text{Max. Relative Error: } \text{M.R.E.} = S_{\text{err}} + \text{NL} + 100 \times \text{Res} / B_{\text{LR}} \quad [\text{unit: \% of } B_{\text{FS}}] \quad \text{Eq. [1]}$$

Here, S_{err} is the tolerance of the sensitivity (relative error in % of S), NL is the maximum relative nonlinearity error (see note 4), Res is the absolute resolution (Notes 6-10) and B_{LR} is the linear range of magnetic flux density.

- 2) The output of the measurement channel has two terminals and the output signal is the (differential) voltage between these two terminals. However, each output terminal can be used also as a single-ended output relative to common signal. In this case the sensitivity is approx. 1/2 of that of the differential output.

Remark: The single-ended outputs are not calibrated.

- 3) **Sensitivity** (also: **magnetic sensitivity**) is given as the nominal slope of an ideal linear function $V_{\text{out}} = f(B)$, i.e.,

$$V_{\text{out}} = S \times B \quad \text{Eq. [2]}$$

where V_{out} , S and B represent transducer output voltage, sensitivity and the measured magnetic flux density, respectively.

- 4) **Nonlinearity** is the deviation of the function $B_{\text{meas}} = f(B_{\text{act}})$ from the best linear fit of this function.

Usually, the maximum of this deviation is expressed in terms of % of the full-scale input.

Accordingly, the nonlinearity error is calculated as follows:

$$\text{NL} = 100 \times \left[\frac{V_{\text{out}} - V_{\text{off}}}{S'} - B \right]_{\text{max}} / B_{\text{LR}} \quad (\text{for } -B_{\text{LR}} < B < B_{\text{LR}}) \quad \text{Eq. [3]}$$

Notation:

B	Actual testing DC magnetic flux density given by a reference high-precision NMR PT2025 teslameter or a high-accuracy 3MH6 digital teslameter
$V_{\text{out}}(B) - V_{\text{off}}$	Corresponding measured transducer output voltage after zeroing the Offset
S'	Slope of the best linear fit of the function $f(B) = V_{\text{out}}(B) - V_{\text{off}}$ (i.e., the actual magnetic sensitivity)
B_{LR}	Linear range of magnetic flux density

Tolerance of sensitivity (also: **sensitivity error**) can be calculated as follows:

$$S_{\text{err}} = 100 \times |S' - S| / S \quad \text{Eq. [4]}$$

- 5) **Planar Hall voltage** is the voltage at the output of a Hall transducer produced by a magnetic flux density vector co-planar with the Hall plate. This voltage is approximately proportional to the square of the measured magnetic flux density. Therefore, for example:

$$\frac{V_{\text{planar}}}{V_{\text{normal}} \big|_{@ B=B_0}} = 4 \times \frac{V_{\text{planar}}}{V_{\text{normal}} \big|_{@ B=B_0/2}} \quad \text{Eq. [5]}$$

where V_{normal} denotes the normal Hall voltage, i.e., the transducer output voltage when the magnetic field is perpendicular to the Hall plate.

- 6) This is the “6-sigma” peak-to-peak span of offset fluctuations with sampling time $\Delta t = 0.05$ s and total measurement time $t = 100$ s. The measurement conditions correspond to the frequency bandwidth from 0.01 Hz to 10 Hz.

The “6-sigma” means that in average 0.27 % of the measurement time offset will exceed the given peak-to-peak span. The corresponding root mean square (RMS) noise equals 1/6 of “Offset fluctuation & drift”.

- 7) Total output RMS noise voltage (of all frequencies) of the transducer. The corresponding peak-to-peak noise is about 6 times the RMS noise. See also Notes 7 and 8.
- 8) Maximal signal bandwidth of the transducer, determined by a built-in low-pass filter with a cut-off frequency Bw . In order to reduce the output noise or avoid aliasing, the frequency bandwidth may be limited by passing the transducer output signal through an external filter (see Notes 8 and 9).
- 9) **Resolution** of the transducer is the smallest detectable change of the magnetic flux density that can be revealed by the output signal. The resolution is limited by the noise of the transducer and depends on the frequency band of interest.

DC resolution is given by the specification “Offset fluctuation & drift” (see also Note 6).

The worst-case (**AC resolution**) is given by the specification “Broad-band noise” (see also Note 7). The resolution of a measurement can be increased by limiting the frequency bandwidth of the transducer. This can be done by passing the transducer output signal through a hardware filter or by averaging the measured values.

Caution: Filtering produces a phase shift, and averaging causes a time delay!

The RMS noise voltage (i.e., resolution) of the transducer in a frequency band from f_L to f_H can be estimated as follows:

$$V_{nRMS-B} \approx \sqrt{NSD_{1f}^2 \times 1\text{Hz} \times \ln\left(\frac{f_H}{f_L}\right) + 1.16 \times NSD_W^2 \times f_H} \quad \text{Eq. [6]}$$

where:

- NSD_{1f} is the 1/f noise voltage spectral density (RMS) @ $f = 1$ Hz;
- NSD_W is the RMS white noise voltage spectral density;
- f_L is the low, and f_H is the high-frequency limit of the frequency bandwidth of interest;
- the numerical factor 1.16 comes under the assumption of using a third-order low-pass filter.

For a DC measurement:

$$f_L = 1/\text{measurement time.}$$

The high-frequency limit cannot be higher than the cut-off frequency of the built-in filter Bw :

$$f_H \leq Bw.$$

If the low-frequency limit f_L is higher than the corner frequency f_C , then the first term in Eq. (5) can be neglected. Otherwise, if the high-frequency limit f_H is lower than the corner frequency f_C , then the second term in Eq. (5) can be neglected.

The corresponding peak-to-peak noise voltage can be calculated according to the “6-sigma” rule:

$$V_{nP-P} \approx 6 \times V_{nRMS-B}.$$

- 10) Let us denote this signal sampling frequency by f_{sams} .

According to the sampling theorem, the sampling frequency must be at least two times higher than the highest frequency of the measured magnetic signal. However, in order to obtain the best signal-to-noise ratio, it is useful to allow for over-sampling (this way we avoid aliasing of high-frequency noise).

Accordingly, for best resolution, the recommended physical sampling frequency of the transducer output voltage is:

$$f_{samps} > 5 \times Bw,$$

or:

$$f_{samP} > 5 \times f_H \text{ (if an additional low-pass filter is used, see Note 8).}$$

The number of samples can be reduced by averaging each N subsequent samples, where is:

$$N \leq f_{samP} / f_{samS}.$$

- 11)** When measuring fast-changing magnetic fields, one should take into account the transport delay of the Hall signals, small inductive signals generated at the connections Hall probe–thin cable, and the filter effect of the electronics in the E-Module. Approximately, the transducer transfer function is similar to that of a third-order low-pass filter, with the frequency bandwidth $f_{(-3\text{ dB})} = BW$.

The attenuation of the applied filter is -60 dB/dec (-18 dB/oct).

The AC Calibration Table (AMP & PHASE vs. FREQ) of the frequency response is available as an option.

- 12)** The equation:

$$V_{PT}[V] = (T_{HALL} [^{\circ}C] - 25 \text{ }^{\circ}C \pm 1 \text{ }^{\circ}C) \times 0.1 [V/^{\circ}C]$$

is valid for the standard temperature range between +5 °C and +45 °C.

For less accurate high temperature calibrations in the range between +20 °C to +160 °C use the equation:

$$V_{PT}[V] = (T_{HALL} [^{\circ}C] - 25 \text{ }^{\circ}C \pm 3 \text{ }^{\circ}C) \times 0.05 [V/^{\circ}C].$$

The temperature-proportional voltage output of the transducer (V_{PT}) is taken from a calibrated temperature sensor in the Hall probe itself. It therefore measures the local temperature of the Hall elements (T_{HALL}), but NOT the ambience (room) temperature.

Due to power loss in the sensor the sensor temperature is always higher than the environmental temperature.

The difference between the temperature of the sensor and the environment is more pronounced if the sensor tip is free hanging in the air. In this case the silicon Hall sensor may be between 5 °C and 12 °C hotter than the environment.

If the sensor is well attached or clamped down on a heat conducting surface, such as a metal, the sensor is typically between 1 °C and 5 °C hotter than the environment.