

METROLab

Magnetic precision has a name

MAGVECTOR™ MV2

3-AXIS MAGNETIC SENSOR

THE WORLD'S MOST FLEXIBLE HALL SENSOR

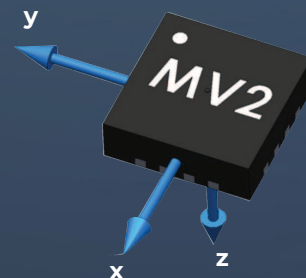

Small package

QFN 3x3x0.9mm³, 16 leads + thermal pad, MRI compatible



Flexible Power

3.3 or 5 V



Flexible Outputs

- > B_x, B_y, B_z, T (on-chip temperature)
- > Analog or digital (SPI)
- > Selectable 3-axis or single-axis



Selectable field ranges

0.1, 0.3, 1, 3, 10 or 30T



Selectable resolution

14, 15, 16 or 16+ bits



Selectable sample rate

375, 750, 1500 or 3000



Microscopic field-sensitive volume

200x200x5μm³



Low noise

RMS < 2.0 LSB (16+ bit resolution)



Integrated spinning current

Suppression of noise, offset, Planar Hall Effect



Parallel Operation

Single SPI bus, multiple Chip Select, synchronized ADC



Wide Operating temperature range

-40 to +125°C, tested in liquid nitrogen

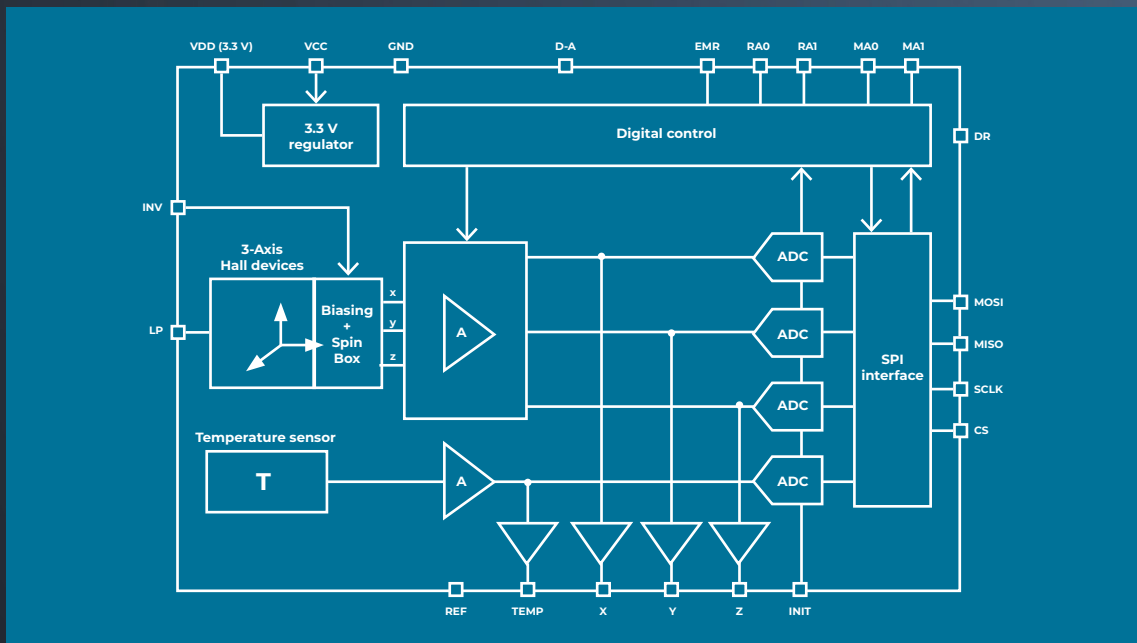

The MagVector™ MV2 allows you to integrate a sophisticated magnetometer into your electronic system. A typical application is a sensor array for magnetic field monitoring. The MV2 was developed by MPS Tech Switzerland Sàrl, in cooperation with Metrolab. Metrolab uses the same sensor in several of its products, and is now making this technology available to electronic systems designers.

Note, that an electronic component such as the MagVector™ MV2 provides none of the amenities of, for example, Metrolab's 3-axis Hall magnetometers: the user must supply the micro-controller, control firmware, host interface, user interface, and, last but not least, calibration.

SMALL BUT POWERFUL

Measuring only $3 \times 3 \times 0.9 \text{ mm}^3$, the MagVector™ MV2 is a powerful magnetometer on a chip: three orthogonal Hall sensors measure (B_x , B_y , B_z); the «spinning current» technique minimizes noise, offset and the Planar Hall Effect; a built-in temperature sensor permits temperature compensation, a programmable-gain amplifier provides measurement ranges from 0.1 to 30 T; and built-in ADCs and SPI (Serial Peripheral Interface) provide a digital interface in addition to an analog one.

HIGH PERFORMANCE

The MV2 features a noise density of $300 \text{ nT}/\sqrt{\text{Hz}}$ and an analog measurement bandwidth of 50 kHz. In digital mode, measurement rate can be traded off against ADC resolution, ranging from 0.375 to 3 kHz, and from 14 to 16+ bits, respectively. It supports a supply voltage of 3.3 or 5 V. The compact $3 \times 3 \text{ mm}^2$ QFN package is completely nonmagnetic, compatible with MRI environments. Please see the Data Sheet for details.

ANALOG AND DIGITAL

A signal pin selects between the analog or digital interface. In analog mode, configuration options such as the measurement range are selected using control signals, whereas in digital mode all configuration parameters are transferred via SPI and stored in internal registers. Additional control signals and register bits provide fine control over the measurement process, for example the timing of the analog/digital conversion. In digital mode, multiple MV2s can be connected to a single SPI bus.

