

DESCRIPTION

The *SENIS* 3-Axis AC Magnetic Transducer 3DACMT-1 is a compact instrument to measure all 3 components of alternating magnetic fields with very high resolution in a small volume.

It incorporates three groups of mutually orthogonal coils, analog integrators and amplifiers within a small cube and generates 3 high level output signals that are immune to electromagnetic disturbances. The sensing cube is completely non magnetic and therefore does not disturb the external field.

The *SENIS* 3DACMT-1 Transducer is ideally suited to measure and map AC magnetic fields in noisy environments with field resolution better than 1.5 μ T.

KEY FEATURES

- Frequency range from 10kHz to 200kHz
- Magnetic field resolution better than 1.5 μ Trms
- Small probe volume of about 4 cm³
- Non-invasive: The probe does not modify the measured magnetic field
- Highly linear response
- High transduction accuracy of $\pm 1\%$
- High phase accuracy: $< 3^\circ$ at 85kHz
- Excellent angular accuracy $< \pm 1^\circ$
- Negligible cross-talk
- Common center of coils for all three axis
- Insensitive to electrical fields or capacitive coupling
- Analog output

PRELIMINARY TECHNICAL SPECIFICATIONS

Geometrical	Value
Size of sensing cube, A	16mm x 16mm x 16mm ± 0.5 mm (for all 3 dimensions)
Probe length (sensing cube with holder), L1	240mm
Cable length, L	3m ± 10 cm
Size electronic box (BxCxD)	150mm x 38mm x 95 mm
Orthogonality of different sensing directions	$< 1^\circ$ in all 3 Cartesian directions
Electrical	
Full measurement range	± 10 mT
Output Signal	Bipolar, single-ended, amplitude from 0V to ± 5 V
Sensitivity	500mV/mT
Magnetic resolution	Better than 1.5 μ Trms for all three axis
Magnetic nonlinearity	$< 1\%$ for $f < 100$ kHz
Measurement bandwidth	10kHz - 200kHz
Phase shift	Better than 3° at 85kHz
Minimum Load Impedance	10k Ω
Output resistance	$< 60\Omega$
Spurious in measurement range	$< 50\mu$ V _{peak} (< 100 nT RTI)
Current consumption	± 45 mA @ ± 12 V

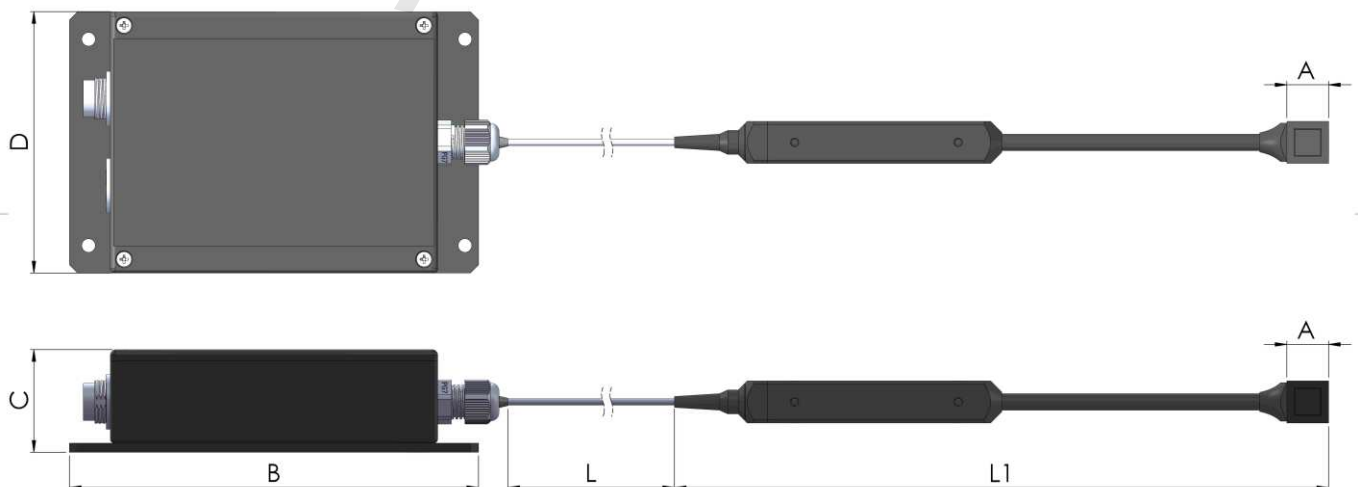

Figure 1. Geometry of the AC Transducer and Probe

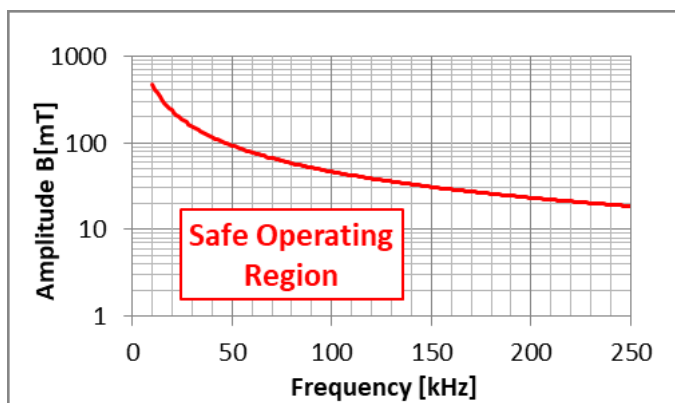

Figure 2a: Safe Operating Region

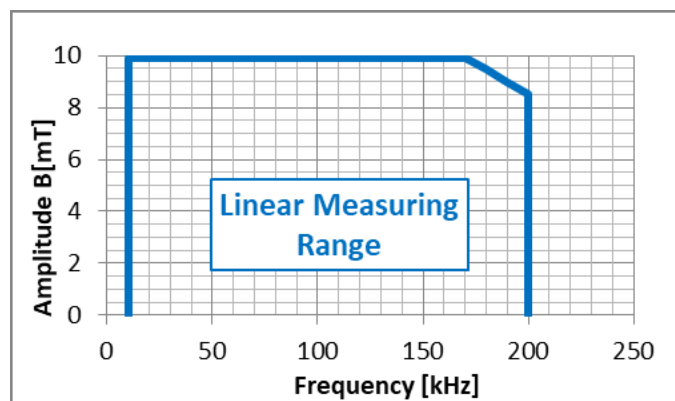

Figure 2b: Linear Measuring Range

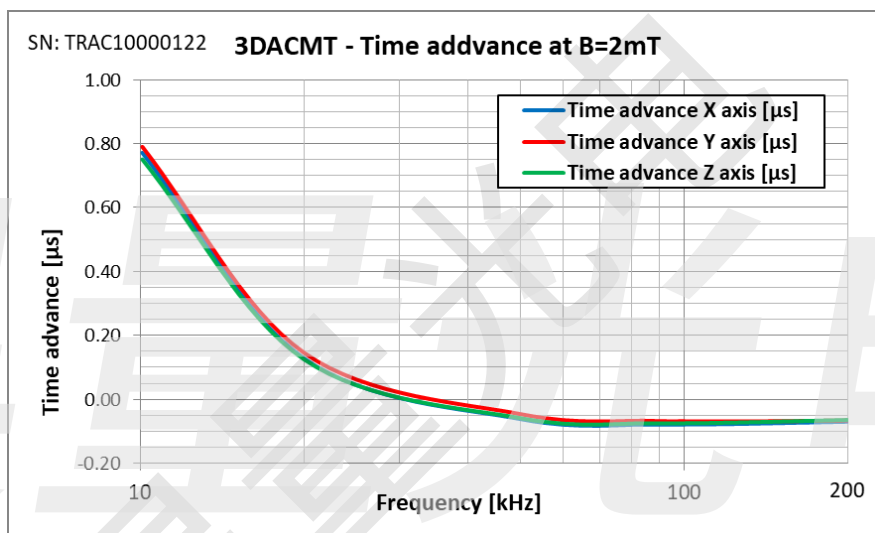

Figure 3: Time advance for all three axes.

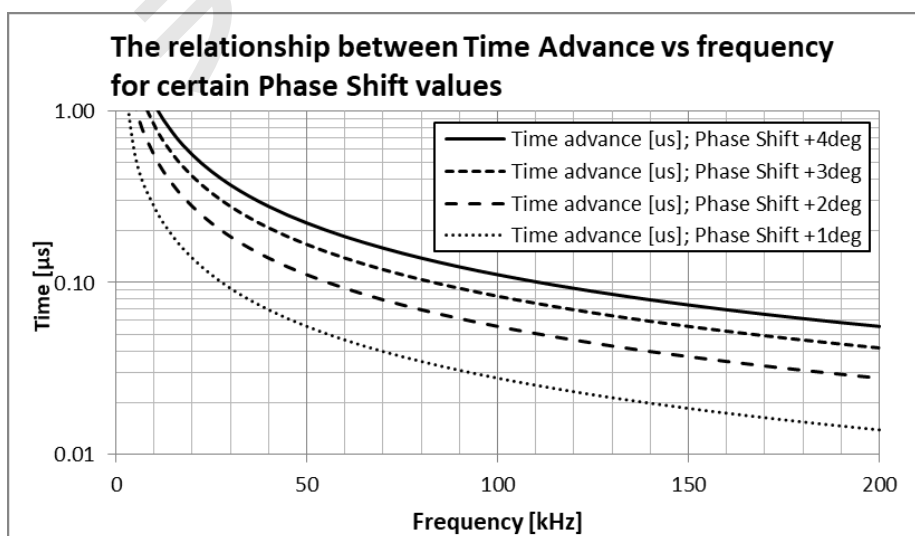

Figure 4: Relationship between Time Advance vs. frequency.

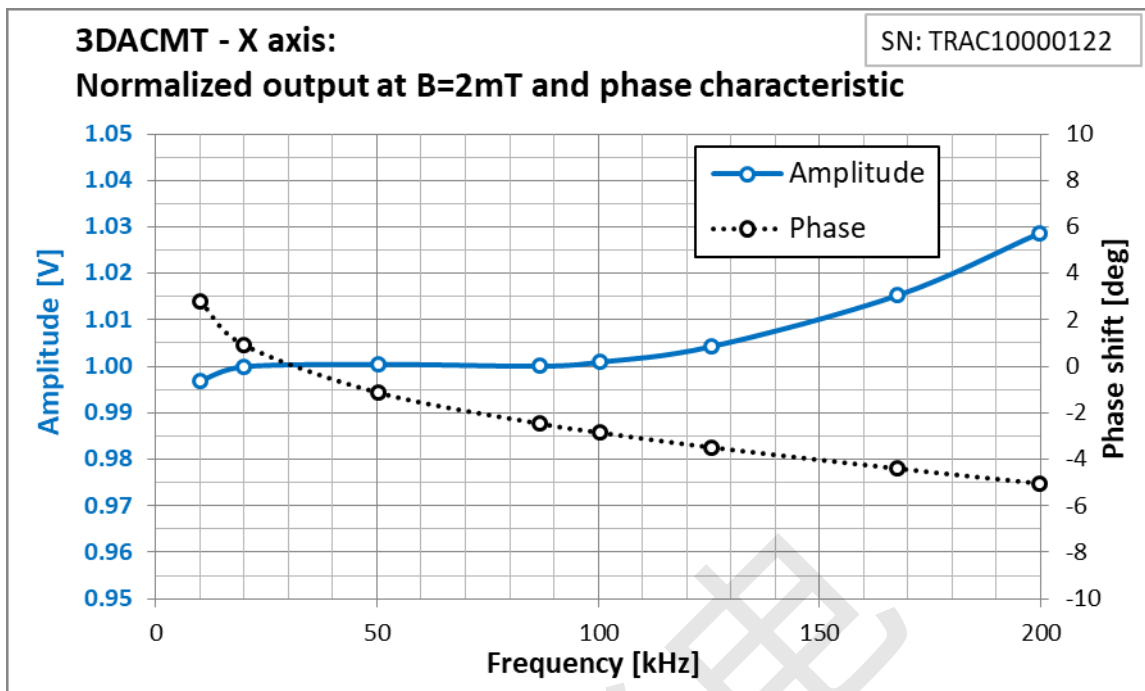

Figure 5: X axis - Normalized Output and Phase Shift.

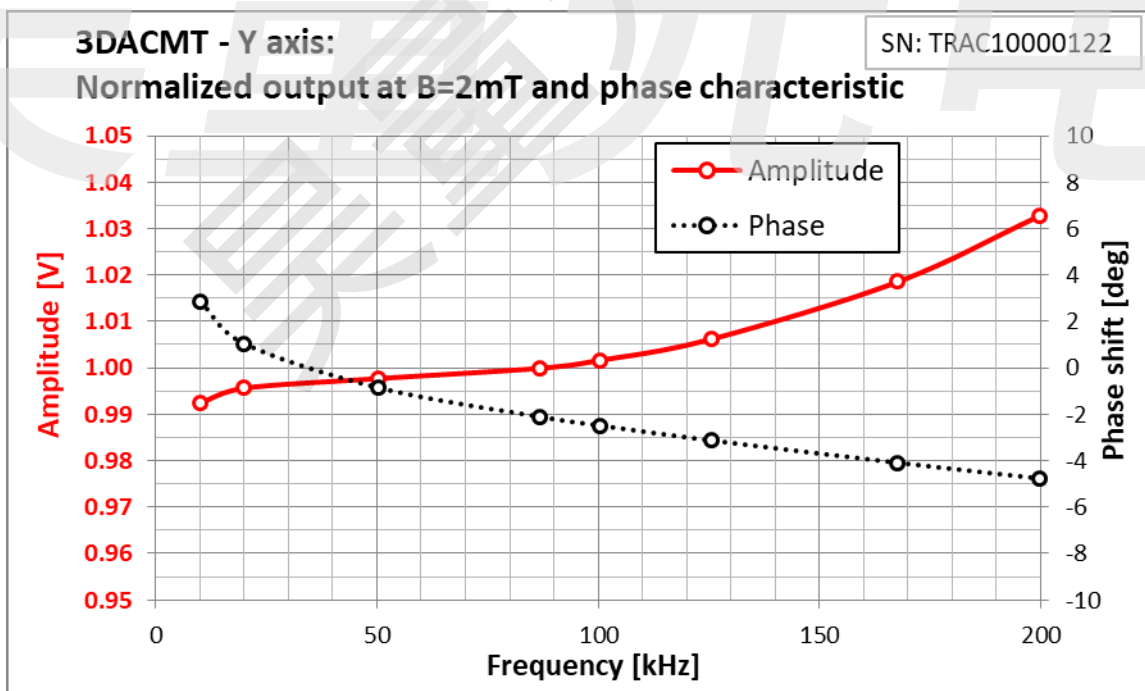

Figure 6: Y axis - Normalized Output and Phase Shift.

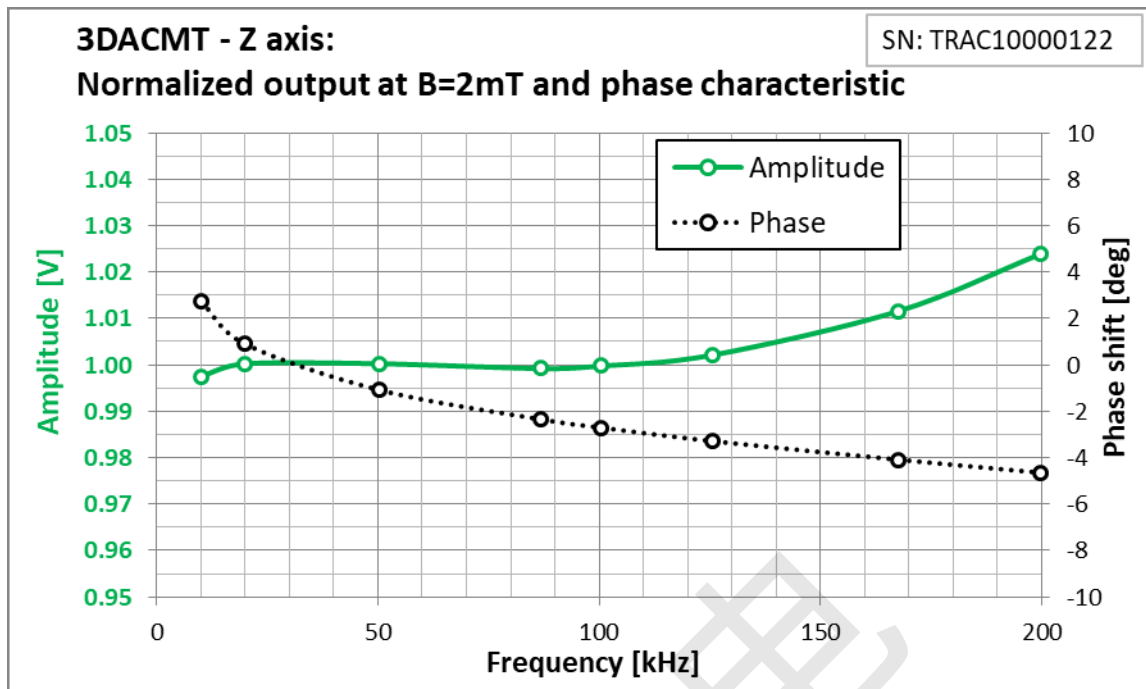

Figure 7: Z axis - Normalized Output and Phase Shift.

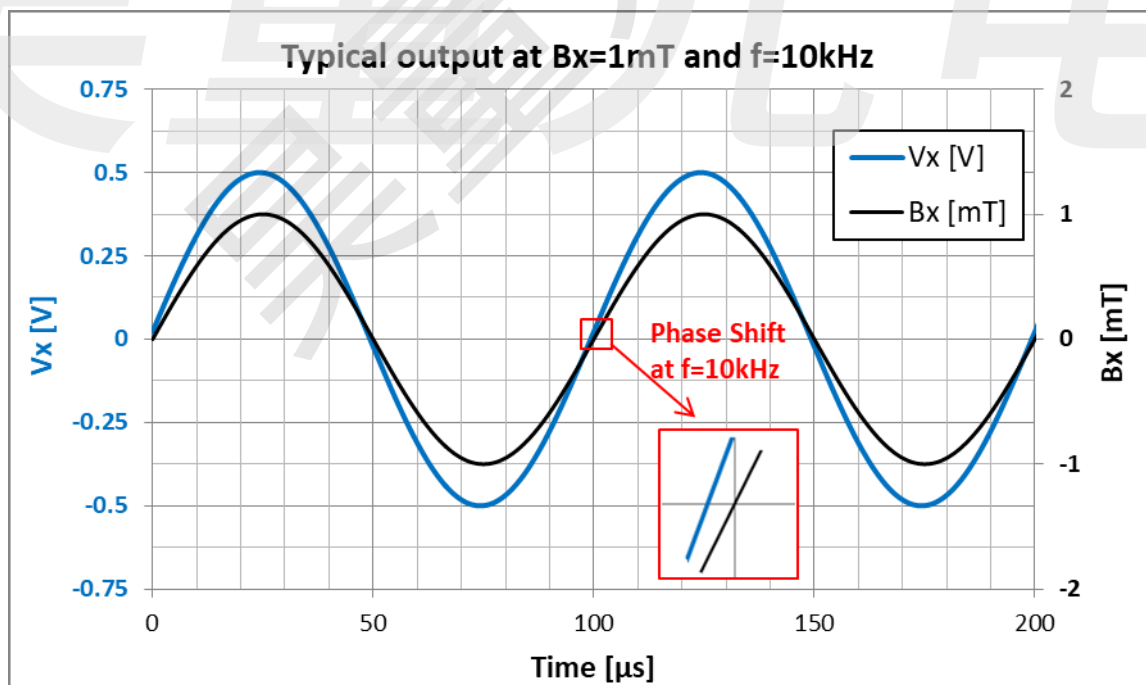

Figure 8: Typical output at B=1mT and f=10kHz

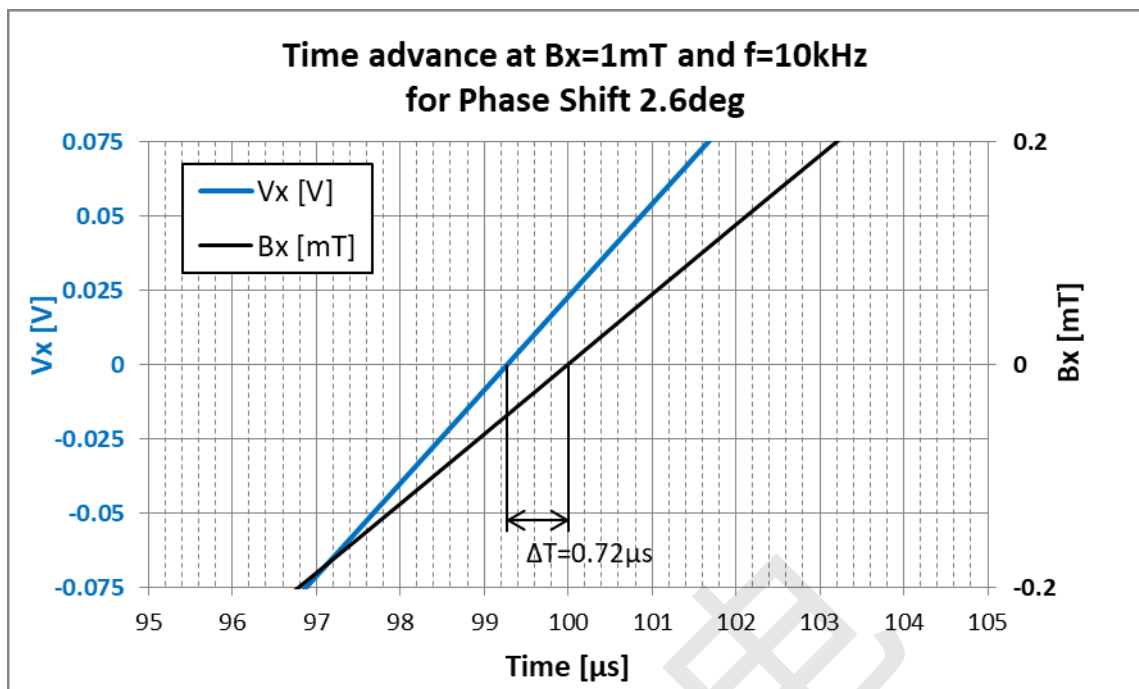

Figure 9: Time advance at zero-crossing for $B_x=1\text{mT}$ and $f=10\text{kHz}$ and Phase Shift 2.6 deg

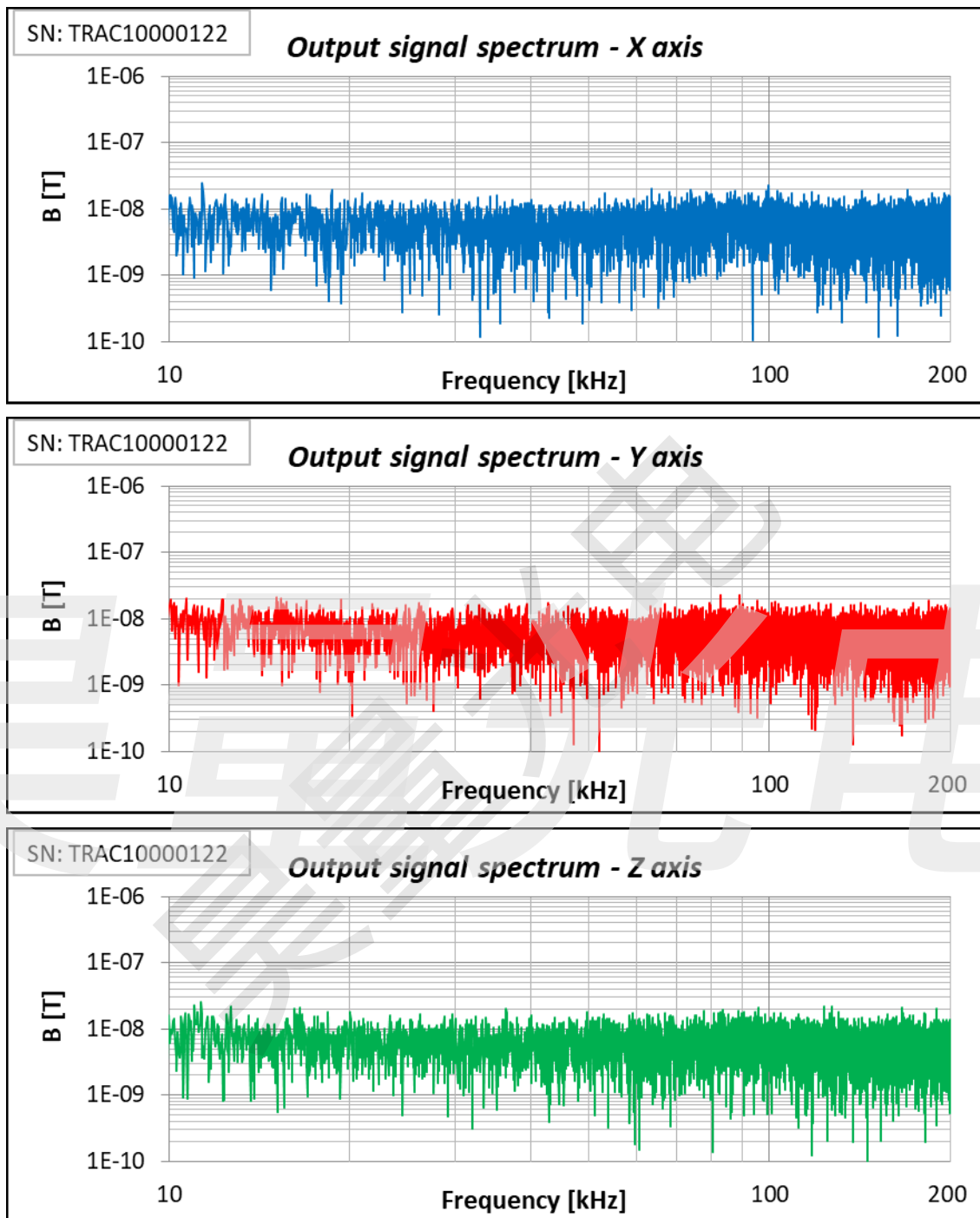

Figure 10: Spectrum of the output signals at $B=0T$.

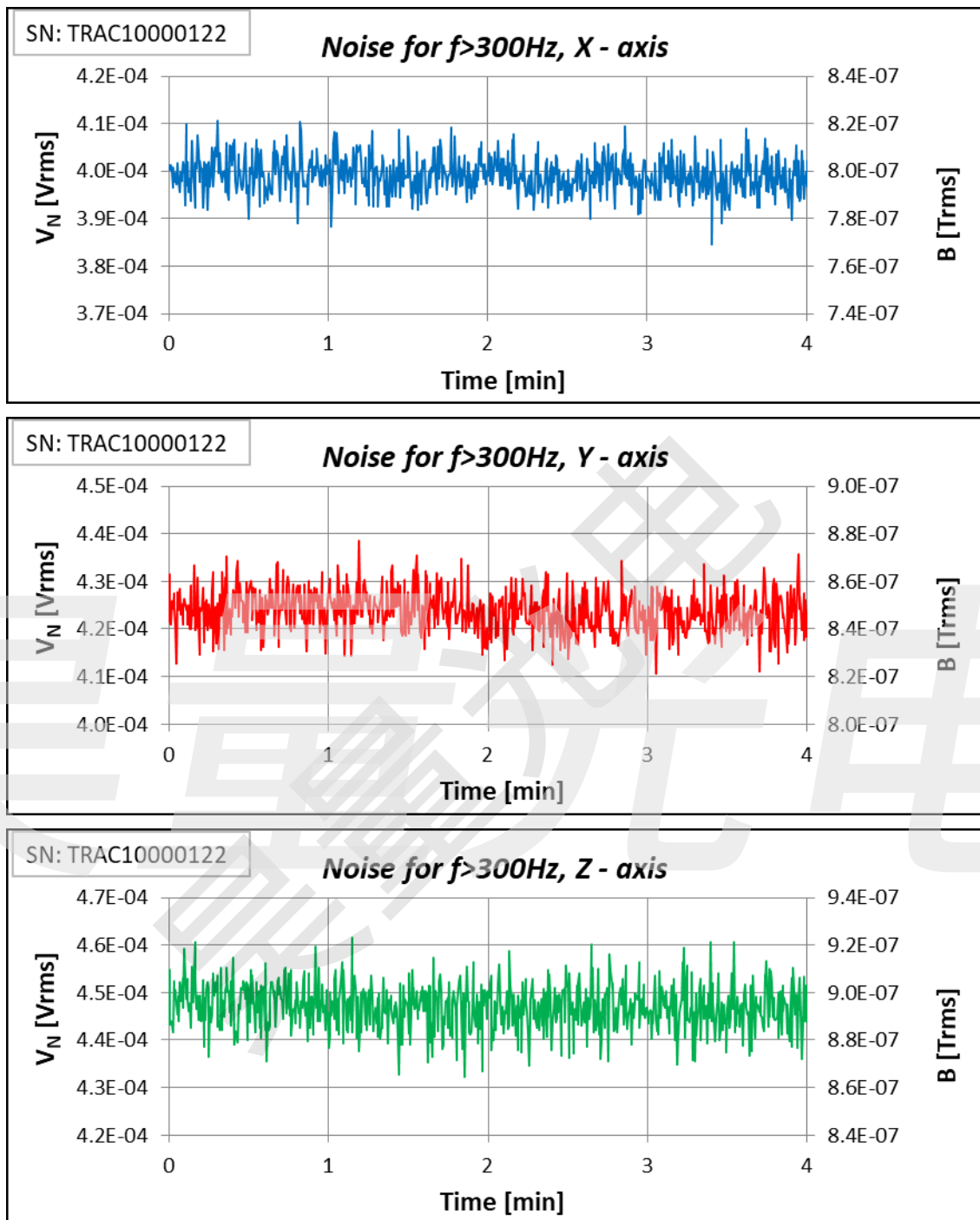

Figure 11: Typical Noise for $f > 300\text{Hz}$, rms Value.

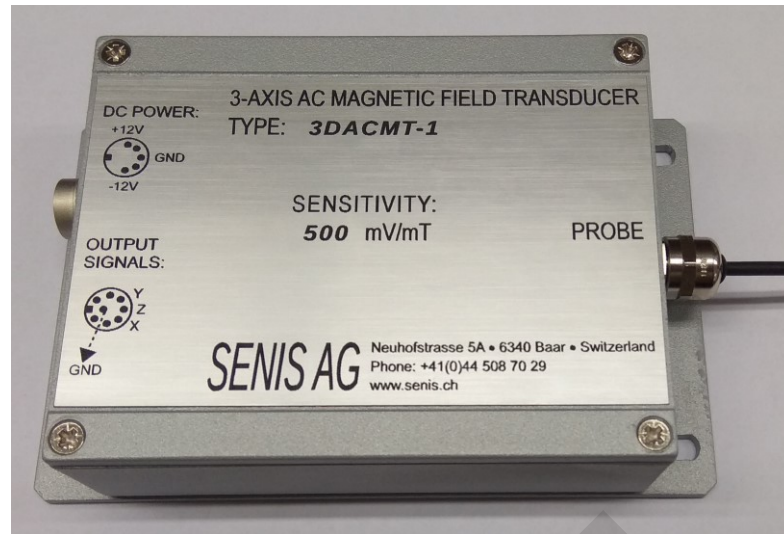

Figure 12: Photo of 3D AC Magnetic Field Transducer.



Figure 13: Probe photo.



Pin No.	Output signal
1	Not used
2	Z axis
3	Not used
4	Y axis
5	X axis
6	Not used
7	Not used
8	GND (Common)

Figure 14: Output signal connector KVF 81 (matching with cable SV81 connector - pin out, front view)

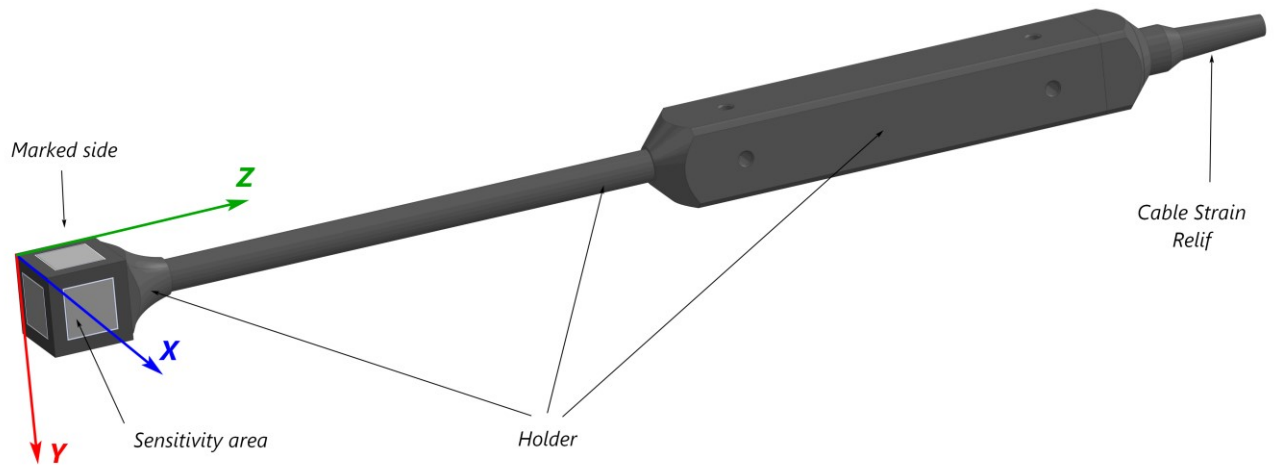

Figure 15: Probe – drawing.

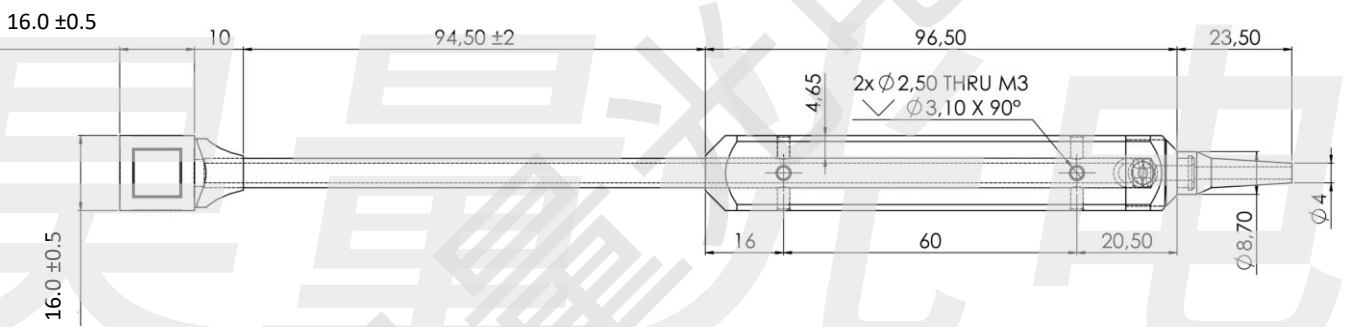

Figure 16: Probe – dimensions (all dimensions are in mm).

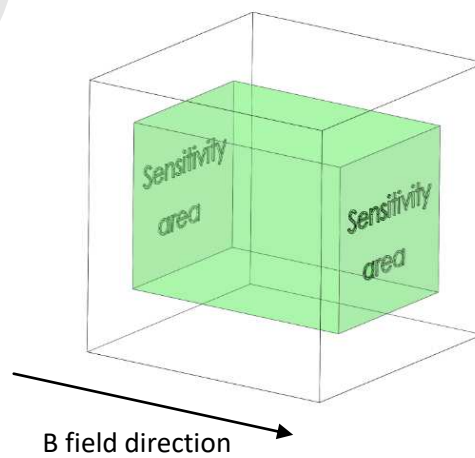

Figure 17: Sensitivity area position for one axis

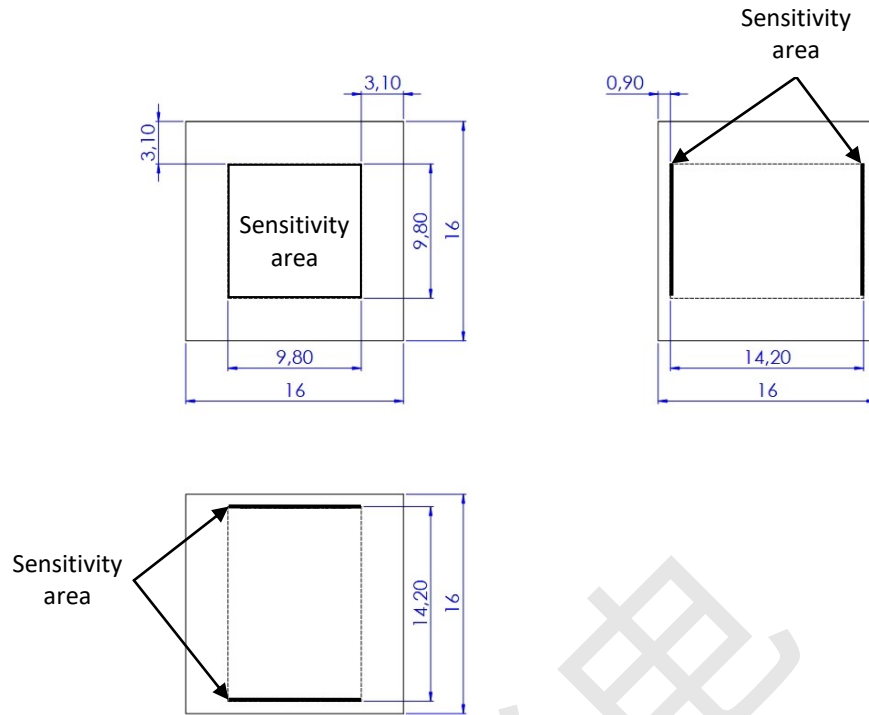

Figure 18: Sensitivity area dimensions and position (all dimensions area in mm).

Appendix A

Output Signals Cable CO10-SE

All output signals should be measured between the desired output (X, Y or Z axis) and GND.



Wire Color	Output Signals
Yellow	X axis
Green	Y axis
Gray	Z axis
Brown	GND
Black	Cable Shield

Figure a1: Output Signals Cable CO10-SE

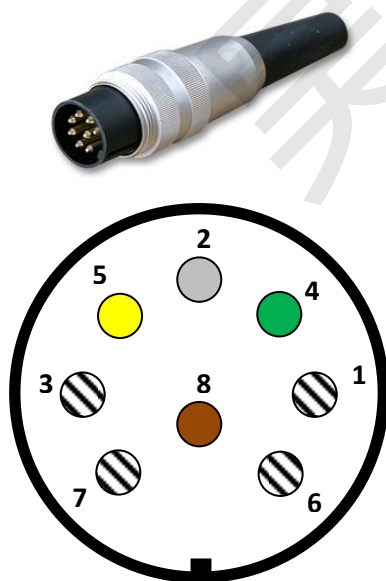

Pin no.	Output signal	Wire color
1	Not Used	
2	Z axis	grey
3	Not Used	
4	Y axis	green
5	X axis	yellow
6	Not Used	
7	Not Used	
8	GND	brown

Figure a2: Cable Connector pins layout – connection side view.

Appendix B

Relations between Power Supply AC lines, Common and +/- voltage rails

Connection between Power Supply S12-5 and 3DACMT-1 is given of Figure b1.

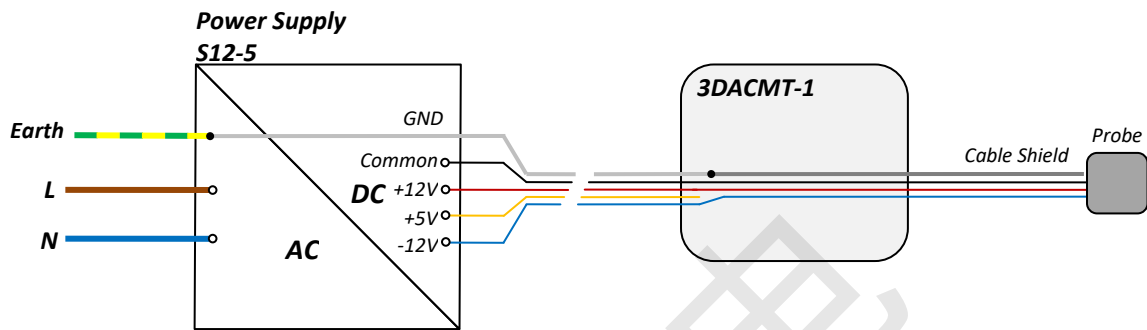

Figure b1.

On Figure a2 is given shield connection of Power Supply S12-5.

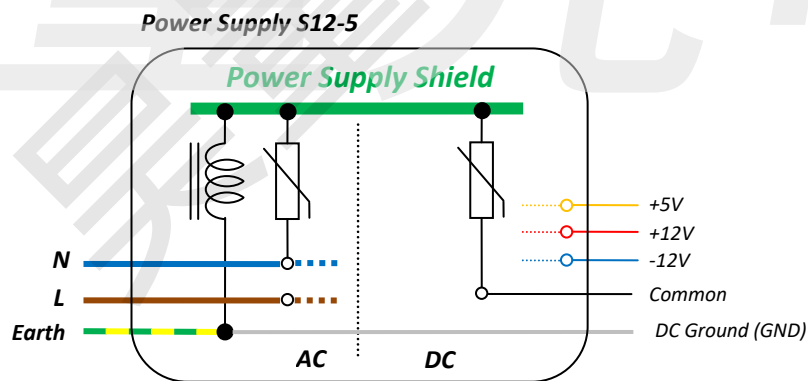

Figure b2.

Appendix C

3DACMT-1 calibration Set-up

Calibration Set-up is given of Figure b1.

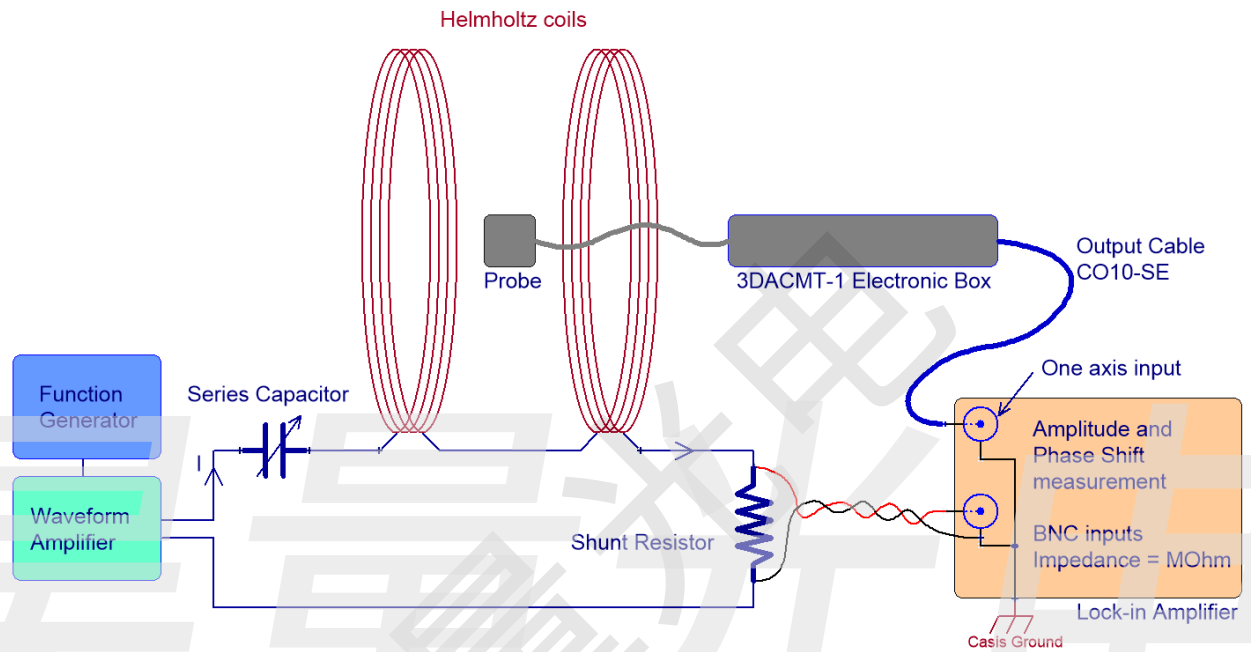

Figure c1.