

FOCHS.100 NANOPositionER

The FOCHS.100 is a tubular design piezotage dedicated to microscope objective high speed nanopositioning. It is offered with 100 microns of travel. The FOCHS.100 is used in a wide range of applications : Z-stack, laser machining, autofocus. It can work also together with automated focus stabilisation devices (for example, CRISP from ASI Imaging). It is made from aluminium, steel and brass. It is equipped with sensor offering stability in the picometer level. The brass mounting ring can be easily exchanged so that almost any objectives can be used .

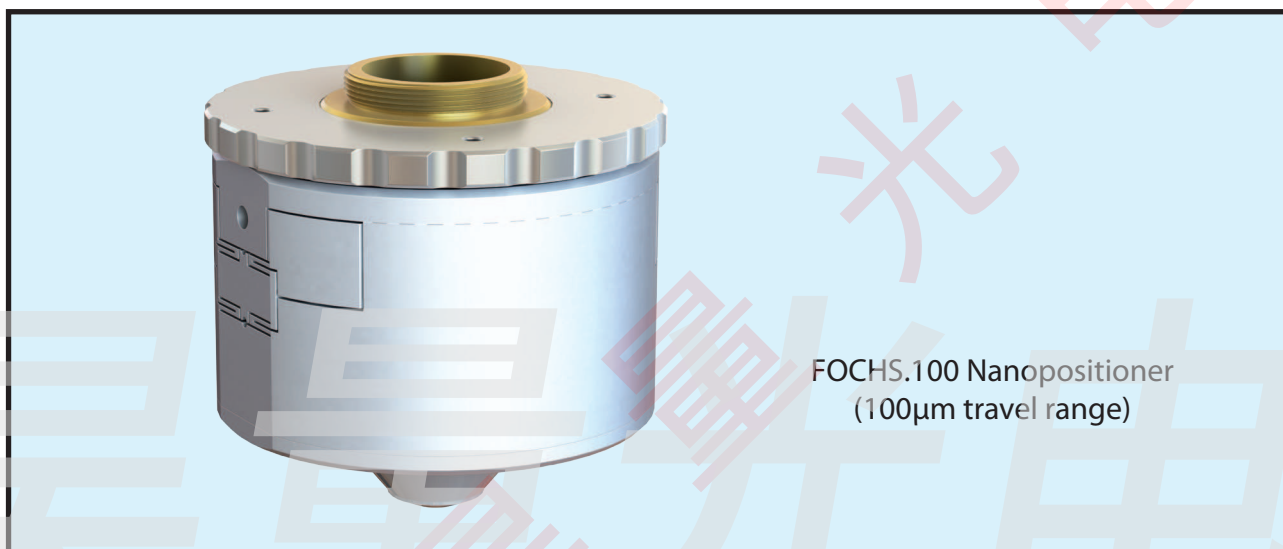

FOCHS.100 Nanopositioner
 (100µm travel range)

Features

- High speed
- Moves objectives with sub-nm resolution
- Parallel flexure guiding
- Closed loop control
- Silicon sensor technology
- Less than 10pm noise floor

Applications

- 3D imaging
- Interferometry
- Autofocus system
- Confocal microscopy
- Super Resolution microscopy
- Semiconductor metrology

Specifications

	FOCHS.100
Range of motion (μm)	100
Resolution (nm)	0,1
Typical noise floor (nm)	0,01
Full range repeatability (nm)	0,2
Linearization (typical)	0,02%
Resonant frequency (Hz)	1175
Stiffness ($\text{N}/\mu\text{m}$)	3,5
Maximum load (kg) - horizontal use	0,5
Maximum load (kg) - vertical use	0,5
Sensor	Silicon HR sensor
Size W x L x H (mm)	$\varnothing 65,5 \times 50,3$
Material	Al
Cable length (m)	2
Recommended Controller	High Speed

Drawing

