

STAR-07 2.0

Option: **RGB**



Multi-Color Industrial Pattern Projection



STAR-07 2.0 is a high performance DLP® projector based upon the Texas Instruments micromirror technology and designed to serve in demanding industrial applications. Widely used in multimedia and digital cinema since more than one decade, the well proven DLP technology has become an important tool for industrial solutions as well. The heart of the STAR-07 2.0 projector is a 0.7" DLP chip that consists of an array of 1024x768 mirrors. These bi-stable mirrors flip into opposite tilt positions within microseconds to generate the desired patterns. STAR-07 2.0 provides precise high-speed control for each individual mirror enabling outstanding flexibility and pattern frame rates of the projection output.

The STAR-07 2.0 projector, option RGB, is equipped with three high-power LED light sources and an integrated cooling system. Typical use cases are 3D volumetric display, 3D measurement, augmented reality applications, and machine vision illumination. Beyond that, new emerging applications are well supported by an open SDK interface. STAR-07 2.0 comes with two lens options, the standard projection lens with zoom capability and a wide angle lens with fixed focal length.

System Architecture

The central control unit of STAR-07 2.0 is USB 2.0 connected and realizes pattern upload, display, and synchronization. An integrated trigger facility supports a wide voltage range at its opto-coupler interface and is software programmable. The digital driver for the LED light source gives convenient access to power setting and temperature reading for thermal management.

System Control

The ViALUX ALP-4.2 Controller Suite is the central programming tool and provides all necessary features for advanced product development. Sequences of patterns are uploaded from PC to the on-board memory via USB 2.0 transfer with lossless compression. The STAR-07 2.0 is USB 2.0 connected and realizes pattern upload, display, and synchronization. Three individual digital drivers for the three LED light sources give convenient access to power setting and temperature reading for thermal management of each single LED. In addition, each LED is gated by a programmable high-speed control line. An integrated trigger facility supports selectable voltage levels for external master or slave modes of control.

The properties of the display sequences, e.g. bit depth, picture time, trigger mode, repetitions can be freely defined to meet the respective application requirements. The ALP-4.2 firmware streams patterns from on-board SDRAM memory to the DLP7000 micromirror array where the input pattern is one-to-one mapped to the mirrors. The patterns are updated in the global reset mode; that means all mirrors are switching simultaneously within a few microseconds. Grey value patterns are generated by controlled ON-time for each mirror yielding exact grey value linearity. The maximum global array switching rate is 22 727 fps. Multiple STAR-07 2.0 devices can be run in parallel, conveniently controlled from the same application program and precisely synchronized by the trigger facility. The ALP-4.2 API is well proven and the DLL supports C++, C#, Visual Basic (.NET), Python, MATLAB, LabVIEW, and other development platforms. Microsoft® operating systems are supported up to the most recent Windows® versions both, 32-bit and 64-bit. The ALP-4 USB 2.0 driver is robust, validated, UIF compliant and 24/7 proven in industrial and medical use.*

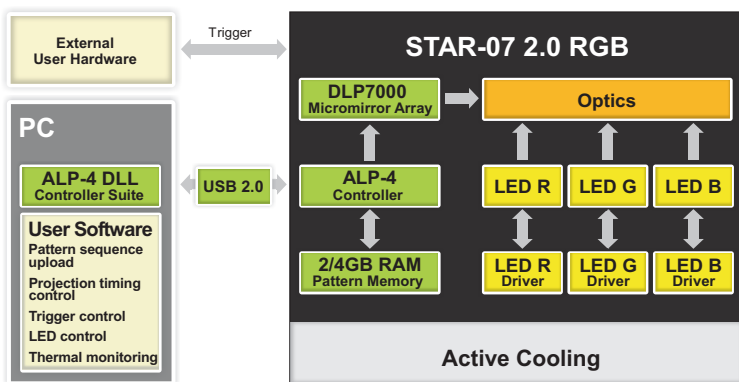

*DLP is a registered trademark of Texas Instruments. Microsoft, Windows, C++, .NET are registered trademarks of Microsoft Cooperation. MATLAB is a registered trademark of MathWorks.

Optical and thermal design

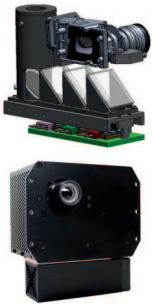

The red, green, and blue light output of each LED is combined and fed into the homogenizer (light tunnel) by means of a dichroic mirror system. The output color of STAR-07 2.0 can be RGB switched with the full frame rate. A common copper heat sink with an active cooler is included for the thermal management of the LED light sources. The temperature monitoring facility of ALP-4.2 provides all the information needed to guarantee safe LED operation within the specified limits.

For detailed information on absolute maximum ratings refer to the LED type printed on the device label and the corresponding data sheets

<https://www.luminus.com/products/color/monochromatic-cob> of the LED manufacturer.

Specifications

LED options

	RED	GREEN	BLUE
Typical dominant wavelength	613 nm	525 nm	460 nm
Spectral bandwidth FWHM	19 nm	34 nm	20 nm
STAR-07 2.0 output*	400 lm 1750 mW	850 lm 1550 mW	140 lm 2550 mW

* Typical value for continuous projection, pulse operation may yield higher output.

Lens options

STAR-07 2.0 Option: RGB	Length L Diameter D Mass M	Distortion	Working distance D Throw ratio TR
Standard lens Part No.: 9052	L = 40 mm D = 35 mm M = 120 g	0.2 %	D > 0.4 m TR= 1.8 ... 2.1
Wide angle lens Part No.: 9591	L = 91 mm D = 81 mm M = 580 g	5.5 %	D > 0.5 m TR= 0.9

Frame rates per color

DMD array (AOI)	1024 x 768	1024 x 768	1024 x 768	1024 x 768	1024 x 768	1024 x 512
Bit depth	8-bit	7-bit	6-bit	5-bit	1-bit	1-bit
Frame rate	290 fps	569 fps	1091 fps	2016 fps	22727 fps	30300 fps

General

Mass (without lens)	Input power	Operating temperature	Storage temperature	Regulations	LED lifetime
3200 g	DC 12-24 V 150 W	10 °C to 40 °C non-condensing	-10 °C to 50 °C non-condensing	CE FCC Class A	> 10000 h (ON time)

Dimensions [mm]

Standard lens	Wide angle lens