

STAR-07 3.0

Options: **UV** **VIS** **RGB**



Industrial Pattern Projection



STAR-07 3.0 is a high performance DLP® projector based upon the Texas Instruments micromirror technology and designed to serve in demanding industrial applications. Widely used in multimedia and digital cinema since more than 20 years, the well proven DLP technology has become an important tool for industrial solutions as well. The heart of the STAR-07 3.0 projector is a 0.7" DLP chip that consists of an array of 1 024x768 mirrors. These bi-stable mirrors flip into opposite tilt positions within microseconds to generate the desired patterns. STAR-07 3.0 provides precise high-speed control for each individual mirror enabling outstanding flexibility and pattern frame rates of the projection output.

The projector is equipped with a high-power LED light source that is the key for the compact and rugged design of the device.

Typical use cases are machine vision illumination, 3D scanning, industrial exposure, and additive manufacturing. Beyond that, new emerging applications are well supported by an open SDK interface. STAR-07 3.0 comes with two lens options, the standard projection lens with zoom capability and a wide angle lens with fixed focal length.

System Architecture

The central control unit of STAR-07 is USB 3.0 connected and realizes pattern upload, display, and synchronization. An integrated trigger facility supports selectable voltage levels and is software programmable. The digital driver for the LED light source gives convenient access to power setting and temperature reading for thermal management.

System Control

The ViALUX ALP-4.4 Controller Suite is the central programming tool and provides all necessary functionality for product development. Sequences of patterns are uploaded from PC to the on-board memory via USB 3.0 transfer with lossless compression. The properties of the display sequences, e.g. bit depth, picture time, trigger mode, repetitions can be freely defined to meet the respective application requirements. The ALP-4.4 firmware streams patterns from on-board SDRAM memory to the DLP7000 micromirror array where the input pattern is one-to-one mapped to the mirrors. The patterns are updated in the global reset mode; that means all mirrors are switching simultaneously within a few microseconds. Grey value patterns are generated by controlled ON-time

for each mirror yielding exact grey value linearity. The maximum global array switching rate is 22 727 fps; even higher frame rates can be achieved by partial updates of the micromirror array. Multiple STAR-07 3.0 devices can be run in parallel, conveniently controlled from the same application program and precisely synchronized by the trigger facility. The ALP-4.4 API is well proven for all DLPC410 chipsets; the DLL supports C++, Python LabVIEW, .NET and other development platforms. Microsoft® operating systems are supported up to the most recent Windows®

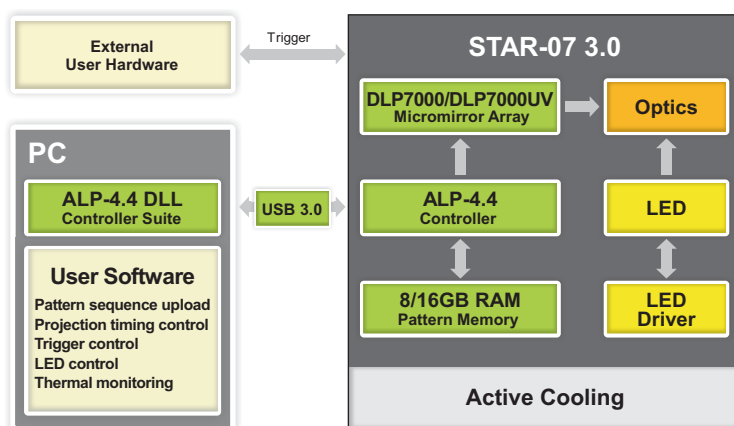

versions both, 32-bit and 64-bit. The ALP-4 USB 3.0 driver is robust, validated, UIF compliant and 24/7 proven in industrial and medical use*.

* DLP is a registered trademark of Texas Instruments. Microsoft, Windows, C++, .NET are registered trademarks of Microsoft Cooperation. MATLAB is a registered trademark of MathWorks.



Specifications

LED options

	RED	GREEN	BLUE	VIOLET	WHITE *
Dominant wavelength	613 nm **	525 nm	460 nm	405/385*/365* nm	-
Spectral bandwidth FWHM	19 nm	34 nm	20 nm	15 nm	-
Optical output ***	330 lm 1 450 mW	850 lm 1 550 mW	140 lm 2 550 mW	- 1 750/2 450/2 550 mW	1 100 lm -

* Not available in STAR-07 3.0 RGB

** 635 nm available on request

*** Typical value for continuous projection, pulse operation may yield higher output.

Lens option

	Length L Diameter D Mass M	Distortion	Working distance D Throw ratio TR	Zoom	Uniformity (IEC) Contrast FOFO	MTF
Standard lens 	L = 36 mm D = 35 mm M = 150 g	0.2 %	D > 0.4 m TR= 1.8 ... 2.1	1.0 – 1.16	+25 % / -30 % 2000:1	45 % @36 lp/mm

Frame rates

DMD array (AOI)	1024 x 768	1024 x 768	1024 x 768	1024 x 768	1024 x 768	1024 x 512
Bit depth	8-bit	7-bit	6-bit	5-bit	1-bit	1-bit
Frame rate	290 fps	569 fps	1 091 fps	2 016 fps	22 727 fps	30 300 fps

Greyscale linearity

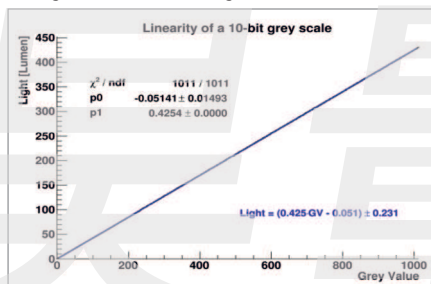

ALP-4 supports precise bit-plane timing enabling outstanding greyscale linearity in connection with synchronized camera recording.

Grey value deviations are < 0.06 % of the full-scale value.

General

Mass (without lens)	Input power	Operating temperature	Storage temperature	Regulations	LED lifetime
3 000 g	DC 19-24 V 150 W	10 °C to 40 °C non-condensing	-10 °C to 50 °C non-condensing	CE FCC Class A	> 10 000 h (ON time)

Dimensions [mm]

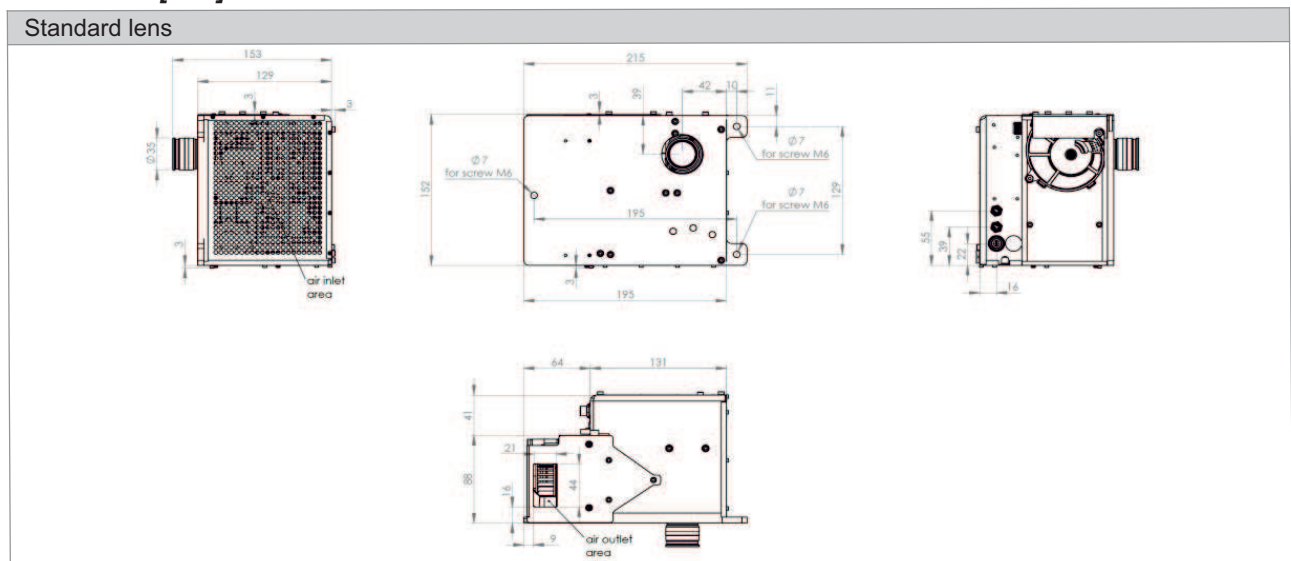

Lens shift

Standard lens

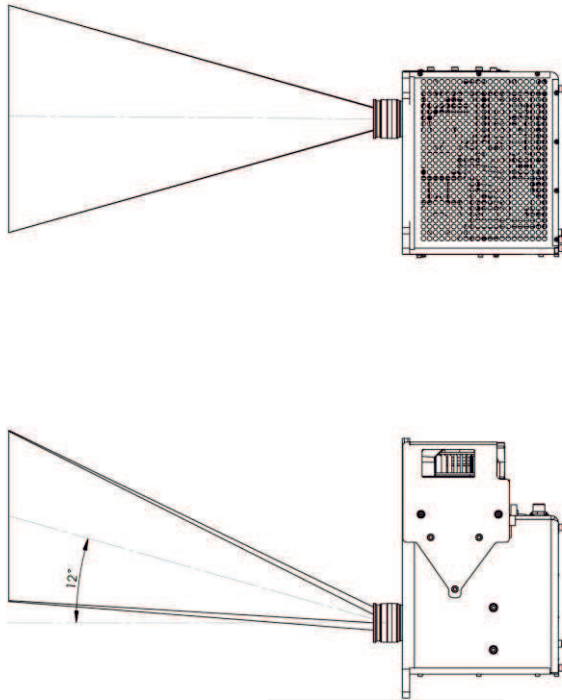

昊量光电



上海昊量光电设备有限公司

地址：上海市徐汇区虹梅路2007号6号楼3楼

上海昊量光电设备有限公司

南方区负责人：步工 18621128645 (微信同号)

北方区负责人：于工 13127820466 (微信同号)

Phone: 4006-888-532 WeChat: Auniontech Website: www.auniontech.com E-mail: info@auniontech.com

VIALUX

Connections

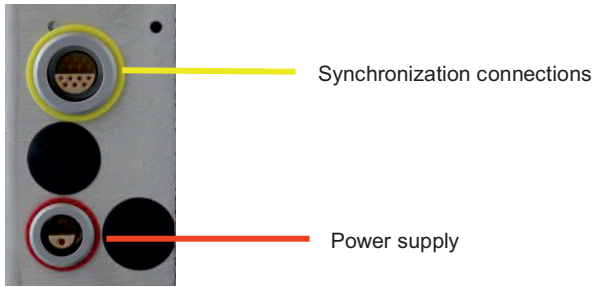

Synchronization:

Pin	Signal	I/O	Limit	Description / usage
1	Dynamic Frame Trigger	Out	5 V, 10 mA	outputs a dynamic frame trigger (ALP Extension DYN_SYNCH_OUT)
2				<i>not connected</i>
3	Frame Trigger	Out	5 V, 10 mA	outputs one pulse per frame, e.g. for synchronizing a slave projector/camera; ALP API commands: • AlpSeqTiming (SynchDelay, SynchPulseWidth): relation to frame timing • AlpDevControl (ALP_SYNCH_POLARITY)
4				<i>not connected</i>
5				<i>not connected</i>
6	DC 5V +	Out	5 V, 350 mA	supply voltage
7				<i>not connected</i>
8				<i>not connected</i>
9				<i>not connected</i>
10	DC 5V GND	GND		supply voltage ground
11				<i>not connected</i>
12				<i>not connected</i>
13				<i>not connected</i>
14	Frame Trigger	In	5 V	triggers next frame in sequence, e.g. for synchronization with a master projector/camera ALP API commands: • AlpProjControl: ALP_PROJ_MODE=ALP_SLAVE • AlpSeqTiming (TriggerInDelay): relation to frame timing • AlpDevControl (ALP_TRIGGER_EDGE)



Lemo plug internal, soldering side

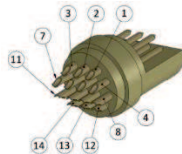

Lemo plug FFA.2C.314.CLAC

Connector: Lemo FFA.2C.314.CLAC52Z with yellow bend relief Lemo:GMA.1B.045.DJ
 Cable: 7x0,14 mm² multiconductor shielded cable, grey, diameter 5.0 mm, Lemo: 070140

Power supply:

Pin	Signal	Description / usage
1	GND	Ground
2	+19 ... 24 V	Positive power supply



Connector: Lemo FFA.1S.302.CLAK82Z with red bend relief Lemo:GMA.2B.070.DR
 Cable: 2x0,5 mm² (AWG20) with shield, diameter 7,2 ... 8,2 mm
 Power supply unit (Example): XP-Power AHM150PS19

USB 3.0:

Use only USB 3.0 cable with high quality.
 Maximum cable length: 3 m