

C Band 110 GHz Mach-Zehnder Modulator

Key Features

- 3-dB electro-optical bandwidth >110 GHz
- Lumped, low-capacitance RF design
- C band operation
- Compact form factor



Performance Data

Peak wavelength	1550 nm
Insertion loss (IL)	<17 dB
Static extinction ratio (ER)	>25 dB
DC bias on/off voltage	<1.5 V
3-dB EO bandwidth	>110 GHz
$V_{\pi,eq}$ @ 100 kHz @ 50 Ohm*	<5 V

Maximum Ratings

Optical input power**	3 dBm
RF input power @ 50 Ohm	18 dBm
DC voltage at RF input	0 V
DC bias voltage	2.5 V
DC bias current	15 mA
Operating / storage temperature	~25 °C

Mechanical and Optical Specifications

Optical input	SMF/PM with FC/APC connectors
Optical output	SMF/PM with FC/APC connectors
Electrical RF interface	Single ended, 1 mm female
Electrical DC interface	2 x DC pins

* Plasmonic modulators are high-impedance devices. Twice the voltage provided by a 50-Ohm signal source will drop across the plasmonic modulator. Using a DC source or a high-impedance-matched driver, double the voltage is required to switch the modulator from the on to the off state.

** Operation time of 8000 h at 20°C with a V_{π} degradation < 10%.

Drawings and Dimensions

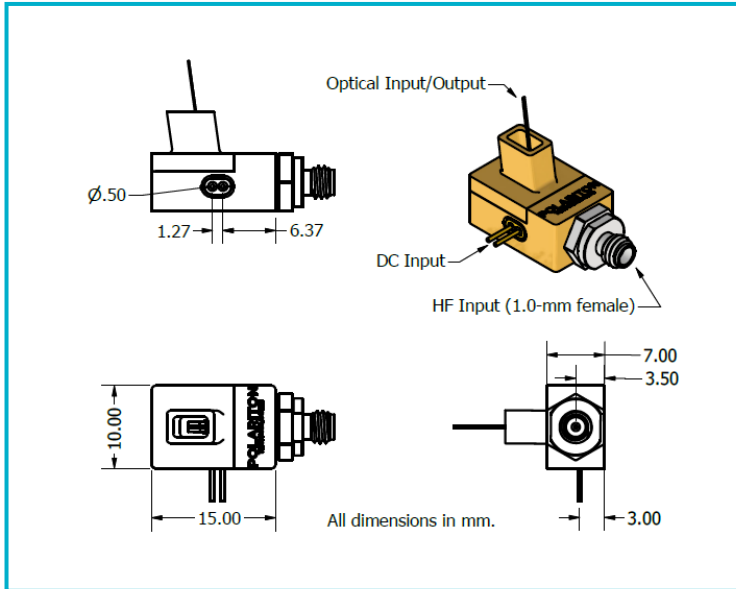

Key Plots

