

# INPHENIX

## Broadband SLD Light Source Module

Part Number: IPSDW0825-xxxxx

### 1. Configuration

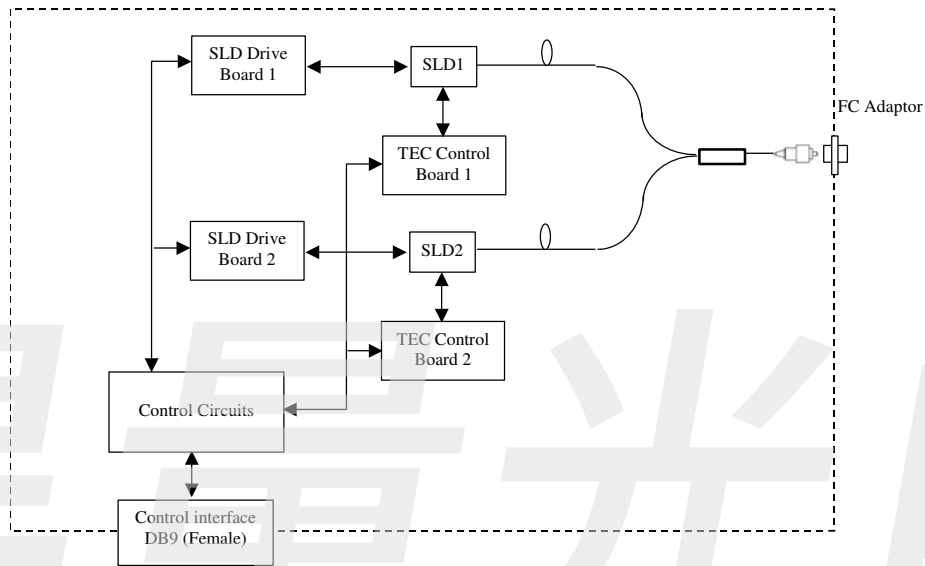

Figure 1 Configuration of IPSDW0825-xxxxx SLD light source module

### 2. Absolute Maximum Ratings

Parameter	Min.	Max.	Unit
Power Supply Voltage	4.5	5.5	V
Storage Temperature	-40	+85	°C
Humidity	10	95	%

### 3. Recommended Operational Condition

Parameter	Min.	Typ.	Max.	Unit
Power Supply Voltage	4.75	5.00	5.25	V
Ripple/spike noise of Power Supply Voltage	-	50	120	mV <sub>p-p</sub>
Operating Temperature (case)	15	25	50	°C
Operating Humidity (case)	30	60	90	%

# INPHENIX

## 4. Optical characteristics

Items	Specifications			Unit	Notes
	Min.	Typ.	Max.		
Center Wavelength	810	850	870	nm	@25°C and CW. Connectors are included.
Total Optical Power	7.5	-	-	mW	
3dB Optical Bandwidth	100	-	-	nm	
Wavelength Range @-6dB	760	-	920	nm	
ASE Ripple @ 0.1nm	-	-	5	%	
Spectrum Flatness	-	1.0	2.0	dB	
Optical Power Stability (8hr)	-	-	±0.1	dB	Stability test of P <sub>max</sub> after 0.5 hour warm up at 25°C.
Optical Output Type	Fiber pigtail or FC Adaptor			-	As shown in Figure 2 of Section 7 in detail
Fiber Connector	FC/APC			-	
Fiber Type	Corning HI780 or equivalent			-	
Fiber Jacket	900µm loose tube			-	
Fiber Length	50	-	-	cm	

## 5. Electrical characteristics

Item	Specifications			Unit	Notes
	Min.	Typ.	Max.		
Power supply current	-	1.2	2.5	A	P <sub>max</sub> CW optical output
Power consumption	-	6.0	13.0	W	
Range of V <sub>set1</sub> and V <sub>set2</sub>	0.0	-	2.5	V	
Input impedance for V <sub>set1,2</sub>	> 20k			ohm	
VH for TTL input/output	3.80	-	-	V	For SLD Enable and Alarm
VL for TTL input/output	-	-	1.02	V	
Optical Power Control	SLD Current Adjustment via V <sub>set1</sub> and V <sub>set2</sub> as shown in Section 6			-	
Connector Type	DB9 Connector, Female			-	See section 6-Pin Allocation in detail

# INPHENIX

## 6. Pin Assignment Specifications

### DB9 Connector (Female) Pin Allocation

Pin #	Function	In/Out	Type	Description
1	<b>+5VDC</b>	IN	Analog (5.0V)	Power Supply, $\leq 2.5A$ .
2				
3	<b>SLD Enable</b>	IN	TTL	SLD turn on control. TTL high turns on SLD and TTL low turns off the SLD. See Figure 3 in detail.
4	<b>Alarm</b>	OUT	TTL	TEC operation status. TTL high indicates TEC failure and TTL low indicates TEC operation is in normal. See Figure 3 in detail.
5	<b>V<sub>SET1</sub></b>	IN	Analog (0~2.5V)	Input voltage to set SLD1 current. The range of 0.0-2.5V for V <sub>SET1</sub> corresponds to 0~I <sub>1max</sub> mA of SLD1 operation current.
6	<b>GND</b>	IN	GND	Power supply and signals GND.
7				
8	<b>V<sub>SET2</sub></b>	IN	Analog (0~2.5V)	Input voltage to set SLD2 current. The range of 0.0-2.5V for V <sub>SET2</sub> corresponds to 0~I <sub>2max</sub> mA of SLD2 operation current.
9	<b>NC</b>	NA	NA	Reserved

# INPHENIX

## 7. Mechanical Specifications

5. Drawing and dimensions (unit: mm)

Size: 120mm (L) × 70mm (W) × 36mm (H)

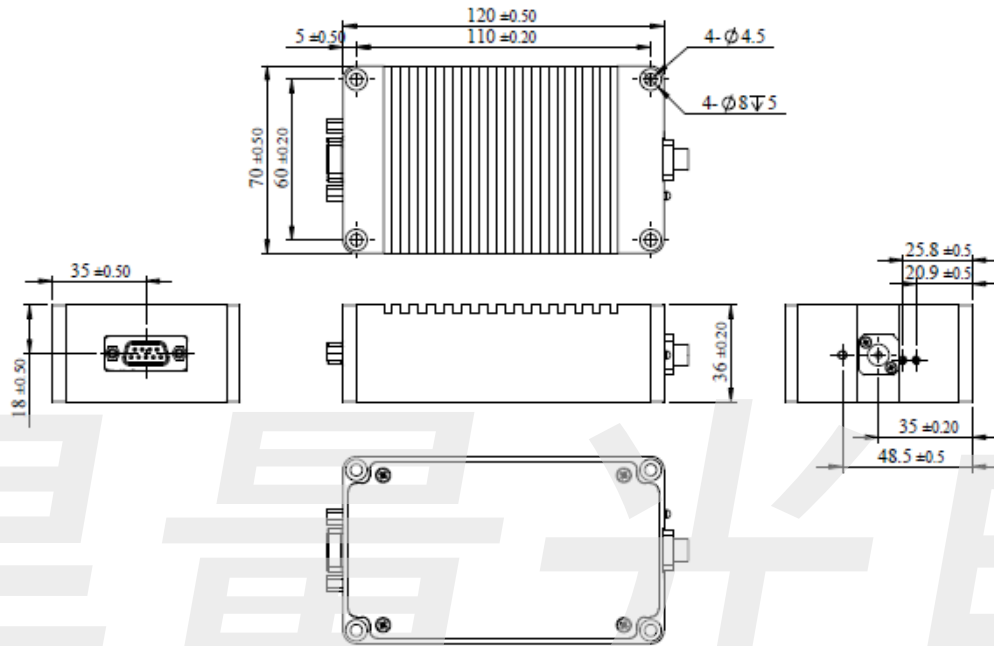

Figure 2 Mechanical drawing of IPSDW0825-0314 module

2. Module case is isolated from any electrical connection.

## 8. Signals Characteristics

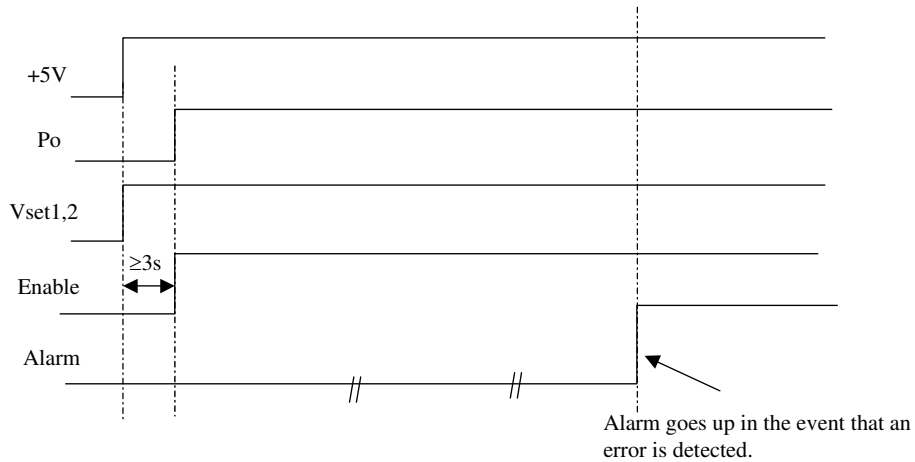
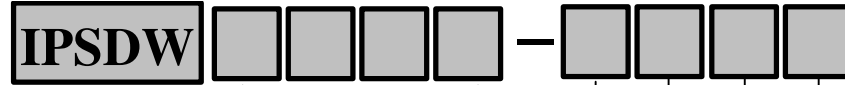

Figure 3 Startup and operational timing of IPSDW0825 module

# INPHENIX

## 9. Part Numbering Structure



**Model Number**

- 07xx: 700~790nm SLD
- 08xx: 800~890nm SLD
- 09xx: 900~990nm SLD
- 10xx: 1010~1090nm SLD
- 13xx: 1300~1390nm SLD
- 15xx: 1500~1590nm SLD

**Output Type**

- 0: FC Adaptor
- 1: Pigtail fiber

**Connector Type**

- 0: No Connectors
- 3: FC/APC    4: FC/UPC
- 7: SC/APC    8: SC/UPC

**Fiber Type**

- 1: 900μm SM Fiber
- 2: 900μm PM Fiber

**Case Size**

- 4: 70×120×36mm case
- 5: 120×100×36mm case

**Example:** IPSDW0821-0314: 800nm-type SLD module in 70×120×36mm case with FC adaptor output, FC/APC connector and 900μm SM Fiber.

Aunion Tech Co.,Ltd

Floor 3, F Building, No. 86 Caobao road, Shanghai 200235 P.R. China

Tel: +86-21-51083793

Fax: +86-21-34241962

E-Mail: info@auniontech.com

Website: www.auniontech.com